

Service Manual

DVD Home Theater Sound System

Model No. **SA-XH20PH**

Product Color: (K)...Black Type

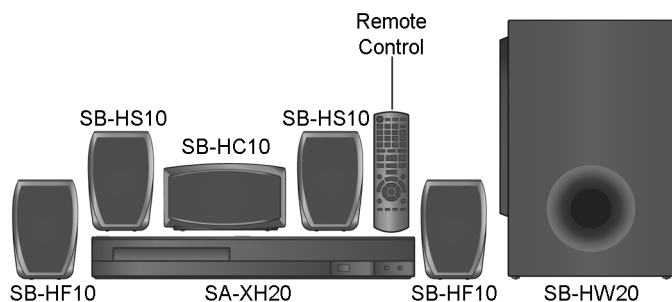

Note: Please refer to the original service manual for:

- DVD Mechanism Unit (BRS1D), Order No. PSG1012001CE
- Speaker system SB-XH70GS-K, Order No. PSG1202009CE

⚠ WARNING

This service information is designed for experienced repair technicians only and is not designed for use by the general public. It does not contain warnings or cautions to advise non-technical individuals of potential dangers in attempting to service a product. Products powered by electricity should be serviced or repaired only by experienced professional technicians. Any attempt to service or repair the product or products dealt with in this service information by anyone else could result in serious injury or death.

IMPORTANT SAFETY NOTICE

There are special components used in this equipment which are important for safety. These parts are marked by ⚠ in the Schematic Diagrams, Circuit Board Diagrams, Exploded Views and Replacement Parts List. It is essential that these critical parts should be replaced with manufacturer's specified parts to prevent shock, fire or other hazards. Do not modify the original design without permission of manufacturer.

TABLE OF CONTENTS

PAGE	PAGE
1 Safety Precautions -----	3
1.1. General Guidelines-----	3
1.2. Before Repair and Adjustment-----	4
1.3. Protection Circuitry-----	4
1.4. Caution For Fuse Replacement-----	4
1.5. Safety Part Information-----	5
2 Warning -----	6
2.1. Prevention of Electrostatic Discharge (ESD) to Electrostatic Sensitive (ES) Devices-----	6
2.2. Precaution of Laser Diode-----	7
2.3. Service caution based on Legal restrictions-----	8
2.4. Handling Precautions for Traverse Unit-----	9
3 Service Navigation -----	11
3.1. Service Information-----	11
4 Specifications -----	12
4.1. Others (Licences)-----	13
5 General/Introduction -----	14
5.1. Power-Saving Features-----	14
5.2. Disc Information-----	15
5.3. DivX Information-----	17
6 Location of Controls and Components -----	18
6.1. Remote Control Key Button Operations-----	18
6.2. Main Unit Key Button Operations-----	19
7 Installation Instructions -----	20
7.1. Speaker Connections-----	20
7.2. Radio Antenna Connection-----	21
8 Operating Instructions -----	22
8.1. Removing of disc during abnormality-----	22
9 Service Mode -----	24
9.1. Cold-Start-----	24
9.2. Panel Code Setting Operation-----	24
9.3. Self Diagnostic-----	27

Panasonic[®]

© Panasonic Corporation 2012. All rights reserved.
Unauthorized copying and distribution is a violation
of law.

9.4. Error Code -----	32	19.2. Illustration of ICs, Transistor and Diode-----	115
9.5. Sales Demonstration Lock Function -----	34	19.3. Terminal Function of ICs -----	116
9.6. Firmware Version-Up Information -----	35	20 Exploded View and Replacement Parts List-----	119
10 Troubleshooting Guide-----	37	20.1. Exploded View and Mechanical Replacement	
10.1. Troubleshooting Guide for F61 and/or F76-----	37	Parts List-----	119
10.2. DVD/CD Laser Diode current measurement-----	40	20.2. Electrical Replacement Parts List -----	122
10.3. Basic Troubleshooting Guide for Traverse			
Unit (Backend P.C.B.)-----	42		
10.4. Basic Troubleshooting Guide for HDMI AV			
output-----	43		
11 Service Fixture & Tools -----	44		
12 Disassembly and Assembly Instructions-----	45		
12.1. Screw Type -----	45		
12.2. Disassembly Flow Chart-----	46		
12.3. Main Components and P.C.B. Locations-----	47		
12.4. Disassembly of Top Cabinet-----	48		
12.5. Replacement of Tray Ornament-----	49		
12.6. Disassembly of Front Panel Block Assembly-----	51		
12.7. Disassembly of Panel P.C.B.-----	52		
12.8. Disassembly of Power Button P.C.B.-----	54		
12.9. Disassembly of Rear Panel-----	55		
12.10. Disassembly of SMPS P.C.B.-----	55		
12.11. Replacement of Current Limiting Switch			
(Q5701)-----	56		
12.12. Replacement of Diode (D5706)-----	57		
12.13. Disassembly of Main P.C.B.-----	58		
12.14. Replacement of Digital Amplifier IC (IC403/			
IC404/IC405)-----	60		
12.15. Disassembly of Backend P.C.B.-----	62		
12.16. Disassembly of Component Video P.C.B.-----	63		
12.17. Disassembly of DVD Mechanism Unit			
(BRS1D)-----	64		
12.18. Replacement of Traverse unit-----	65		
13 Service Position -----	70		
13.1. Checking & Repairing of Panel P.C.B.-----	70		
13.2. Checking & Repairing of SMPS P.C.B.-----	70		
13.3. Checking & Repairing Main P.C.B.-----	71		
13.4. Checking & Repairing of Backend P.C.B.-----	73		
14 Overall Simplified Block Diagram -----	75		
15 Block Diagram -----	76		
15.1. Backend-----	76		
15.2. IC Terminal Chart-----	77		
15.3. System Control-----	78		
15.4. Audio & Video-----	79		
15.5. Power Supply-----	80		
16 Wiring Connection Diagram-----	82		
17 Schematic Diagram-----	83		
17.1. Schematic Diagram Notes-----	83		
17.2. Backend Circuit-----	85		
17.3. Main Circuit-----	90		
17.4. Panel and Power Button Circuit-----	98		
17.5. SMPS Circuit-----	99		
17.6. Component Video Circuit-----	101		
18 Printed Circuit Board -----	102		
18.1. Backend P.C.B.-----	102		
18.2. Main P.C.B.-----	103		
18.3. Panel, Power Button and Component Video			
P.C.B.-----	105		
18.4. SMPS P.C.B.-----	106		
19 Appendix Information of Schematic Diagram-----	107		
19.1. Voltage & Waveform Chart-----	107		

1 Safety Precautions

1.1. General Guidelines

1. When servicing, observe the original lead dress. If a short circuit is found, replace all parts which have been overheated or damaged by the short circuit.
2. After servicing, see to it that all the protective devices such as insulation barriers, insulation papers shields are properly installed.
3. After servicing, carry out the following leakage current checks to prevent the customer from being exposed to shock hazards.

1.1.1. Leakage Current Cold Check

1. Unplug the AC cord and connect a jumper between the two prongs on the plug.
2. Measure the resistance value, with an ohmmeter, between the jumpered AC plug and each exposed metallic cabinet part on the equipment such as screwheads, connectors, control shafts, etc. When the exposed metallic part has a return path to the chassis, the reading should be between $1M\Omega$ and $5.2M\Omega$.

When the exposed metal does not have a return path to the chassis, the reading must be ∞

1.1.2. Leakage Current Hot Check

1. Plug the AC cord directly into the AC outlet. Do not use an isolation transformer for this check.
2. Connect a $1.5k\Omega$, 10 watts resistor, in parallel with a $0.15\mu F$ capacitors, between each exposed metallic part on the set and a good earth ground such as a water pipe, as shown in Figure 1.
3. Use an AC voltmeter, with 1000 ohms/volt or more sensitivity, to measure the potential across the resistor.
4. Check each exposed metallic part, and measure the voltage at each point.
5. Reverse the AC plug in the AC outlet and repeat each of the above measurements.
6. The potential at any point should not exceed 0.75 volts RMS. A leakage current tester (Simpson Model 229 or equivalent) may be used to make the hot checks, leakage current must not exceed 1/2 milliamp. In case a measurement is outside of the limits specified, there is a possibility of a shock hazard, and the equipment should be repaired and rechecked before it is returned to the customer.

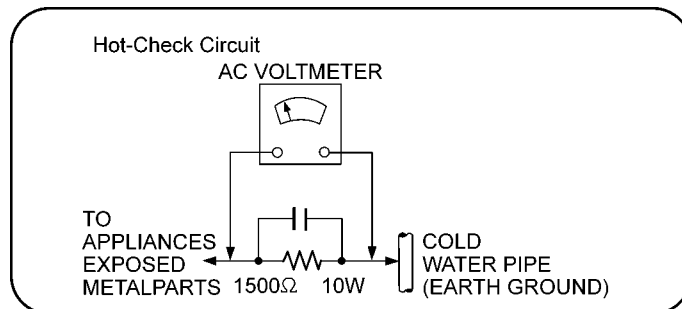

Figure 1

1.2. Before Repair and Adjustment

Disconnect AC power to discharge unit AC Capacitors as such (C5702, C5703, C5704, C5705, C5706) through a 10 Ω , 10 W resistor to ground.

Caution:

DO NOT SHORT-CIRCUIT DIRECTLY (with a screwdriver blade, for instance), as this may destroy solid state devices.

After repairs are completed, restore power gradually using a variac, to avoid overcurrent.

Current consumption at AC 110/127V, 50/60 Hz in NO SIGNAL mode at volume minimal should be ~ 500 mA.

Current consumption at AC 240V, 50 Hz in NO SIGNAL mode at volume minimal should be ~ 500 mA.

1.3. Protection Circuitry

The protection circuitry may have operated if either of the following conditions are noticed:

- No sound is heard when the power is turned on.
- Sound stops during a performance.

The function of this circuitry is to prevent circuitry damage if, for example, the positive and negative speaker connection wires are “shorted”, or if speaker systems with an impedance less than the indicated rated impedance of the amplifier are used.

If this occurs, follow the procedure outlines below:

1. Turn off the power.
2. Determine the cause of the problem and correct it.
3. Turn on the power once again after one minute.

Note:

When the protection circuitry functions, the unit will not operate unless the power is first turned off and then on again.

1.4. Caution For Fuse Replacement

CAUTION:

Replace with the same type fuse:

(Manufacturer: SkyGate, Type: SCT, F1, T3.15A, 250V)

1.5. Safety Part Information

Safety Parts List:

There are special components used in this equipment which are important for safety.

These parts are marked by \triangle in the Schematic Diagrams, Exploded View & Replacement Parts List. It is essential that these critical parts should be replaced with manufacturer's specified parts to prevent shock, fire or other hazards. Do not modify the original design without permission of manufacturer.

Safety	Ref No.	Part No.	Part Name & Description	Remarks
\triangle	8	RGRX1004E-D1	REAR PANEL	
\triangle	16	RKMX1009-K	TOP CABINET	
\triangle	21	RMNX1050	BOTTOM PC SHEET	
\triangle	27	RMN1017	TOP PC SHEET	
\triangle	301	RAY1101-V	TRAVERSE ASS'Y	
\triangle	A2	K2CQ2CA00006	AC CORD	
\triangle	A3	RQT9570-M	O/I BOOK (Sp)	
\triangle	PCB5	REP4764C	SMPS P.C.B.	(RTL)
\triangle	DZ5701	ERZVA5Z471	ZNR	
\triangle	L5701	G0B722G00002	LINE FILTER	
\triangle	L5702	G0B453G00003	LINE FILTER	
\triangle	F1	K5G312Y00007	FUSE	
\triangle	T2900	G4D1A0000142	SWITCHING TRANSFORMER	
\triangle	T5701	ETS35BL146AC	SWITCHING TRANSFORMER	
\triangle	PC701	B3PBA0000579	PHOTO COUPLER	
\triangle	TH5701	D4CC11040013	THERMISTOR	
\triangle	TH5702	D4CAA5R10001	THERMISTOR	
\triangle	P5701	K2AA2B000011	AC INLET	
\triangle	R5701	D0GB824JA008	820K 1/10W	
\triangle	R5702	D0GB824JA008	820K 1/10W	
\triangle	R5703	D0GB824JA008	820K 1/10W	
\triangle	R5704	D0GB824JA008	820K 1/10W	
\triangle	C5702	F0CAF104A105	0.1uF	
\triangle	C5703	F0CAF104A105	0.1uF	
\triangle	C5704	F1BAF1020020	1000pF	
\triangle	C5705	F1BAF1020020	1000pF	
\triangle	C5706	F1BAF1020020	1000pF	

2 Warning

2.1. Prevention of Electrostatic Discharge (ESD) to Electrostatic Sensitive (ES) Devices

Some semiconductor (solid state) devices can be damaged easily by static electricity. Such components commonly are called Electrostatically Sensitive (ES) Devices. Examples of typical ES devices are integrated circuits and some field-effect transistors and semiconductor “chip” components. The following techniques should be used to help reduce the incidence of component damage caused by electrostatic discharge (ESD).

1. Immediately before handling any semiconductor component or semiconductor-equipped assembly, drain off any ESD on your body by touching a known earth ground. Alternatively, obtain and wear a commercially available discharging ESD wrist strap, which should be removed for potential shock reasons prior to applying power to the unit under test.
2. After removing an electrical assembly equipped with ES devices, place the assembly on a conductive surface such as aluminum foil, to prevent electrostatic charge build up or exposure of the assembly.
3. Use only a grounded-tip soldering iron to solder or unsolder ES devices.
4. Use only an anti-static solder removal device. Some solder removal devices not classified as “anti-static (ESD protected)” can generate electrical charge sufficient to damage ES devices.
5. Do not use freon-propelled chemicals. These can generate electrical charges sufficient to damage ES devices.
6. Do not remove a replacement ES device from its protective package until immediately before you are ready to install it. (Most replacement ES devices are packaged with leads electrically shorted together by conductive foam, aluminum foil or comparable conductive material).
7. Immediately before removing the protective material from the leads of a replacement ES device, touch the protective material to the chassis or circuit assembly into which the device will be installed.

Caution:

Be sure no power is applied to the chassis or circuit, and observe all other safety precautions.

8. Minimize bodily motions when handling unpackaged replacement ES devices. (Otherwise harmless motion such as the brushing together of your clothes fabric or the lifting of your foot from a carpeted floor can generate static electricity (ESD) sufficient to damage an ES device).

2.2. Precaution of Laser Diode

CAUTION:

THIS PRODUCT UTILIZES A LASER.

USE OF CONTROLS OR ADJUSTMENTS OR PERFORMANCE OF PROCEDURES OTHER THAN THOSE SPECIFIED HEREIN MAY RESULT IN HAZARDOUS RADIATION EXPOSURE.

Caution:

This product utilizes a laser diode with the unit turned "on", invisible laser radiation is emitted from the pickup lens.

Wavelength: 655 nm (DVD)/790 nm (CD)

Maximum output radiation power from pickup: 100 μ W/VDE

Laser radiation from the pickup unit is safety level, but be sure the followings:

1. Do not disassemble the pickup unit, since radiation from exposed laser diode is dangerous.
2. Do not adjust the variable resistor on the pickup unit. It was already adjusted.
3. Do not look at the focus lens using optical instruments.
4. Recommend not to look at pickup lens for a long time.

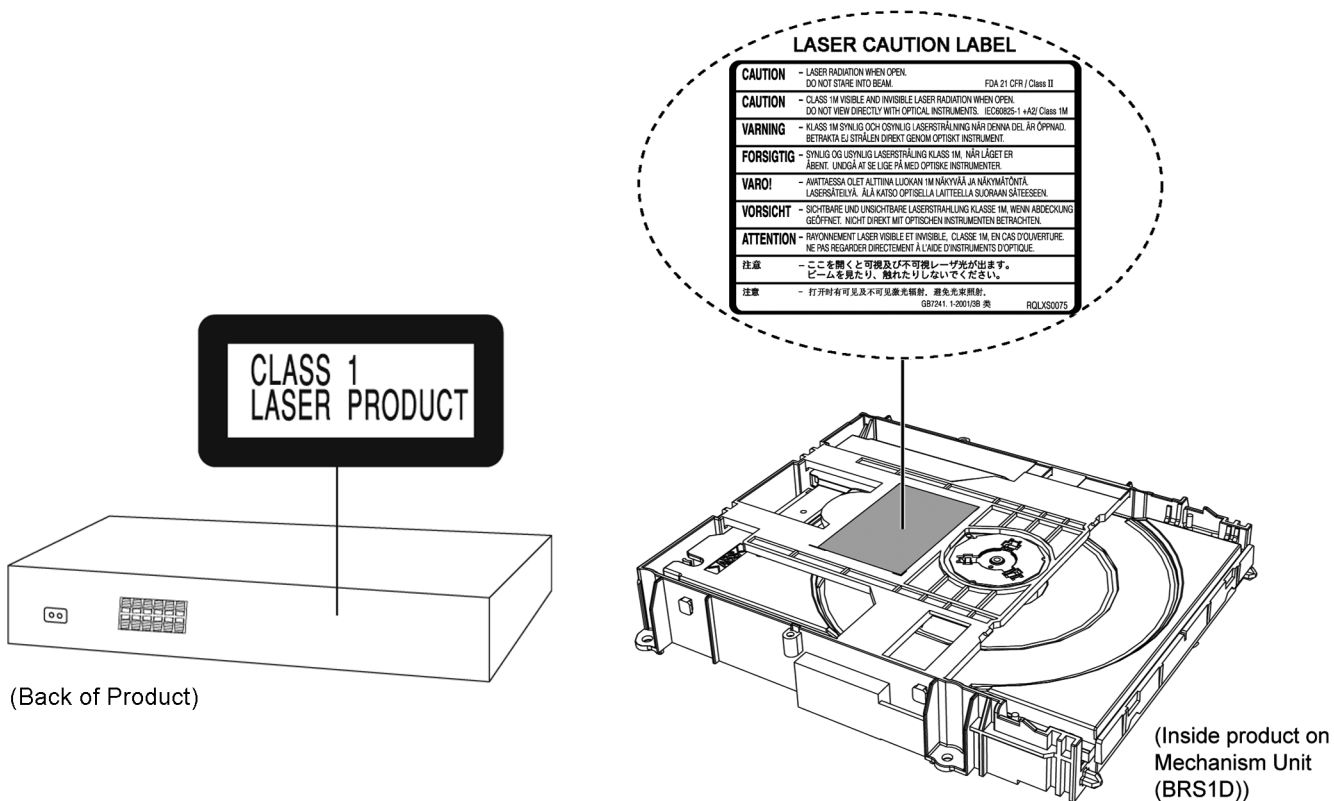

2.3. Service caution based on Legal restrictions

2.3.1. General description about Lead Free Solder (PbF)

The lead free solder has been used in the mounting process of all electrical components on the printed circuit boards used for this equipment in considering the globally environmental conservation.

The normal solder is the alloy of tin (Sn) and lead (Pb). On the other hand, the lead free solder is the alloy mainly consists of tin (Sn), silver (Ag) and Copper (Cu), and the melting point of the lead free solder is higher approx.30 degrees C (86°F) more than that of the normal solder.

Definition of PCB Lead Free Solder being used

The letter of "PbF" is printed either foil side or components side on the PCB using the lead free solder.	PbF
(See right figure)	

Service caution for repair work using Lead Free Solder (PbF)

- The lead free solder has to be used when repairing the equipment for which the lead free solder is used.
(Definition: The letter of "PbF" is printed on the PCB using the lead free solder.)
- To put lead free solder, it should be well molten and mixed with the original lead free solder.
- Remove the remaining lead free solder on the PCB cleanly for soldering of the new IC.
- Since the melting point of the lead free solder is higher than that of the normal lead solder, it takes the longer time to melt the lead free solder.
- Use the soldering iron (more than 70W) equipped with the temperature control after setting the temperature at 350±30 degrees C (662±86°F).

Recommended Lead Free Solder (Service Parts Route.)

- The following 3 types of lead free solder are available through the service parts route.
 - RFKZ03D01K----- (0.3mm 100g Reel)
 - RFKZ06D01K----- (0.6mm 100g Reel)
 - RFKZ10D01K----- (1.0mm 100g Reel)

Note

* Ingredient: tin (Sn), 96.5%, silver (Ag) 3.0%, Copper (Cu) 0.5%, Cobalt (Co) / Germanium (Ge) 0.1 to 0.3%

2.4. Handling Precautions for Traverse Unit

The laser diode in the optical pickup unit may break down due to static electricity of clothes or human body. Special care must be taken avoid caution to electrostatic breakdown when servicing and handling the laser diode in the traverse unit.

2.4.1. Cautions to Be Taken in Handling the Optical Pickup Unit

The laser diode in the optical pickup unit may be damaged due to electrostatic discharge generating from clothes or human body. Special care must be taken avoid caution to electrostatic discharge damage when servicing the laser diode.

1. Do not give a considerable shock to the optical pickup unit as it has an extremely high-precise structure.
2. To prevent the laser diode from the electrostatic discharge damage, the flexible cable of the optical pickup unit removed should be short-circuited with a short pin or a clip.
3. The flexible cable may be cut off if an excessive force is applied to it. Use caution when handling the flexible cable.
4. The antistatic FPC is connected to the new optical pickup unit. After replacing the optical pickup unit and connecting the flexible cable, cut off the antistatic FPC.

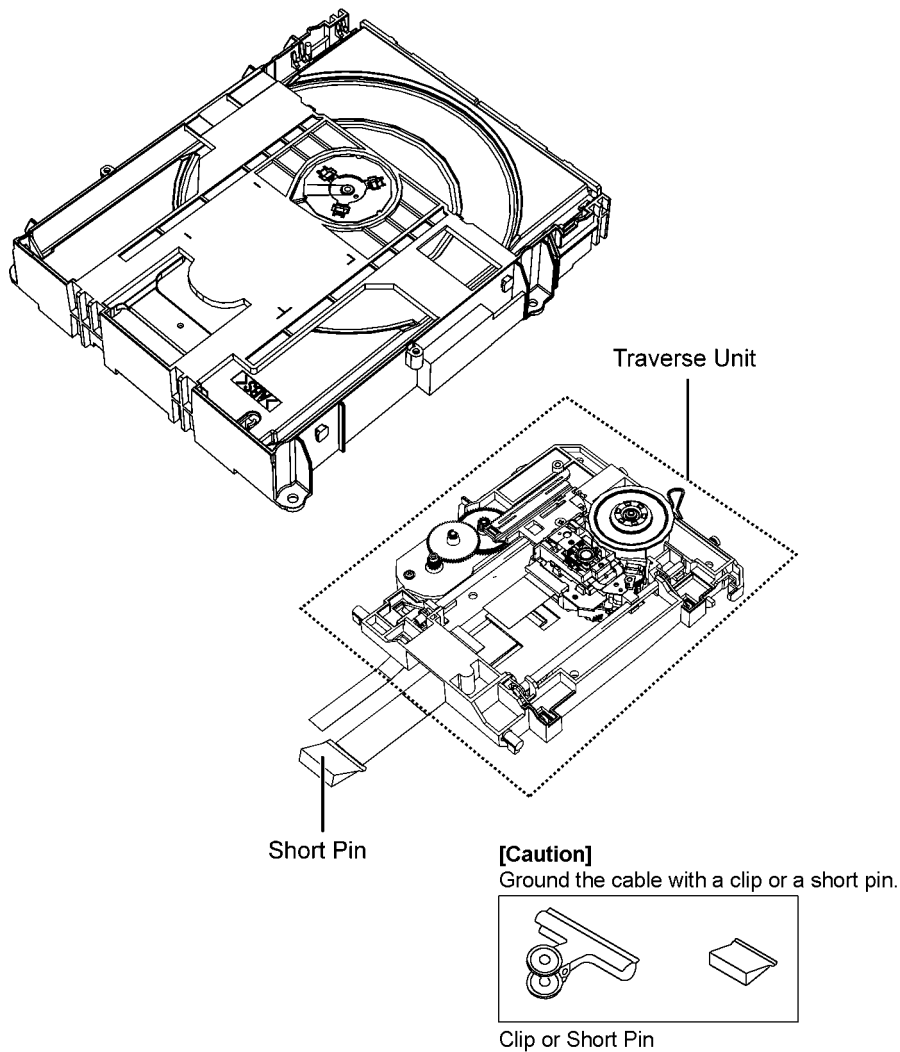

Figure 1

2.4.2. Grounding for electrostatic breakdown prevention

Some devices such as the DVD player use the optical pickup (laser diode) and the optical pickup will be damaged by static electricity in the working environment. Proceed servicing works under the working environment where grounding works is completed.

2.4.2.1. Worktable grounding

1. Put a conductive material (sheet) or iron sheet on the area where the optical pickup is placed, and ground the sheet.

2.4.2.2. Human body grounding

1. Use the anti-static wrist strap to discharge the static electricity form your body.

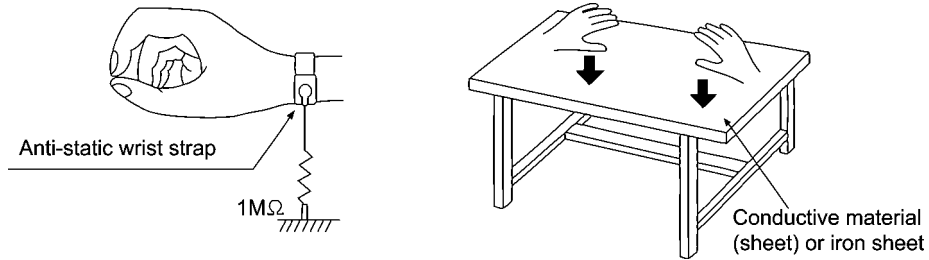

Figure 2

3 Service Navigation

3.1. Service Information

This service manual contains technical information which will allow service personnel's to understand and service this model. Please place orders using the parts list and not the drawing reference numbers.

If the circuit is changed or modified, this information will be followed by supplement service manual to be filed with original service manual.

- **DVD Mechanism Unit (BRS1D):**

1) This model uses DVD Mechanism Unit (BRS1D).

- **Micro-processor:**

1) The following components are supplied as an assembled part.

- Micro-processor IC, IC200 (RFKWMXH70EB)

4 Specifications

Main unit

●AMPLIFIER SECTION

RMS Output Power: Dolby Digital Mode

Front Ch	55 W per channel (5 Ω), 1 kHz, 10% THD
Surround Ch	55 W per channel (5 Ω), 1 kHz, 10% THD
Center Ch	55 W per channel (5 Ω), 1 kHz, 10% THD
Subwoofer Ch	80 W per channel (3 Ω), 100 Hz, 10% THD
Total RMS Dolby Digital mode power	355 W

Front Ch	67 W per channel (5 Ω), 1 kHz, 30% THD
Surround Ch	67 W per channel (5 Ω), 1 kHz, 30% THD
Center Ch	67 W per channel (5 Ω), 1 kHz, 30% THD
Subwoofer Ch	100 W per channel (3 Ω), 100 Hz, 30% THD
Total RMS Dolby Digital mode power	435 W

●FM TUNER, TERMINALS SECTION

Preset Memory FM 30 stations

Frequency Modulation (FM)

Frequency range 87.50 MHz to 108.00 MHz (50-kHz step)

Antenna terminals 75 Ω (unbalanced)

Digital audio input

Optical digital input Optical terminal

Sampling frequency 32 kHz, 44.1 kHz, 48 kHz

USB Port

USB standard USB 2.0 Full Speed

Media file format support MP3 (*.mp3)

JPEG (*.jpg, *.jpeg)

DivX (*.divx, *.avi)

USB device file system FAT12, FAT16, FAT32

USB Port power Max. 500 mA

Bit rate Up to 4 Mbps (DivX)

●DISC SECTION

Discs played (8 cm or 12 cm)

- (1) DVD (DVD-Video, DivX^{*4, 5})
- (2) DVD-R (DVD-Video, MP3^{*2, 4}, JPEG^{*3, 4}, DivX^{*4, 5})
- (3) DVD-R DL (DVD-Video, DivX^{*4, 5})
- (4) DVD-RW (DVD-Video, MP3^{*2, 4}, JPEG^{*3, 4}, DivX^{*4, 5})
- (5) +R/+RW (Video)
- (6) +R DL (Video)
- (7) CD, CD-R/RW (CD-DA, Video CD, SVCD^{*1}, MP3^{*2, 4}, JPEG^{*3, 4}, DivX^{*4, 5})

^{*1} Conforming to IEC62107

^{*2} MPEG-1 Layer 3, MPEG-2 Layer 3, MPEG-2.5 Layer 3

^{*3} Exif Ver 2.1 JPEG Baseline files

Picture resolution:

16:9 min. size 4 x 4, max. size (720 x 8) x (405 x 8);

4:3 min. size 4 x 4, max. size (720 x 8) x (540 x 8)

^{*4} The total combined maximum number of recognizable audio, picture and video contents and groups: 2600 audio, picture and video contents and 259 groups. (Excluding Root folder)

^{*5} Plays DivX[®] video

Pick up

Wavelength (DVD/CD) 655/790 nm

Laser power CLASS 1

Audio output (Disc)

Number of channels 5.1 ch (FL, FR, C, SL, SR, SW)

●VIDEO SECTION

Video system

NTSC

Composite video output

Output level 1 Vp-p (75 Ω)

Terminal Pin jack (1 system)

Component video output

Y output level 1 Vp-p (75 Ω)

P_B output level 0.7 Vp-p (75 Ω)

P_R output level 0.7 Vp-p (75 Ω)

Terminal Pin jack (Y: green, P_B: blue, P_R: red) (1 system)

●GENERAL

Power supply AC 110 V to 240 V, 50/60 Hz

Power consumption Main Unit 50 W

Dimensions (W×H×D) 360 mm × 48 mm × 273 mm

Mass Main unit 2.0 kg

Operating temperature range 0 °C to +40 °C

Operating humidity range: 35 % to 80 % RH (no condensation)

Power Consumption in standby mode:

approx. 0.45 W

Note:

1. Specifications are subject to change without notice.
- Mass and dimensions are approximate.
2. Total harmonic distortion is measured by the digital spectrum analyzer.

Solder:

This model uses lead free solder (PbF).

System	SC-XH20PH-K
Main unit	SA-XH20PH-K
Speakers system	SB-XH70GS-K ^{*1}

Refer to their respective original service manuals for *1.

4.1. Others (Licences)

Manufactured under license from Dolby Laboratories. Dolby, Pro Logic, and the double-D symbol are trademarks of Dolby Laboratories.

This item incorporates copy protection technology that is protected by U.S. patents and other intellectual property rights of Rovi Corporation. Reverse engineering and disassembly are prohibited.

"DVD Logo" is a trademark of DVD Format/Logo Licensing Corporation.

DivX®, DivX Certified® and associated logos are trademarks of Rovi Corporation or its subsidiaries and are used under license.

MPEG Layer-3 audio coding technology licensed from Fraunhofer IIS and Thomson.

5 General/Introduction



5.1. Power-Saving Features

POWER-SAVING FEATURES
<p>The main unit is designed to conserve its power consumption and save energy.</p> <p>■ Auto power-down function</p> <ul style="list-style-type: none">● The main unit will automatically switch to standby mode after 30 minutes of inactivity. e.g.<ul style="list-style-type: none">– There is no audio signal from an external device.– Media playback is stopped/paused.– The disc menu is displayed and play is not selected. (This function may not work depending on the application type of discs.)● When the main unit is turned back on, "POWER ON FROM AUTO POWER DOWN MODE" appears on the main unit's display.

5.2. Disc Information

5.2.1. Media that can be played

Commercial discs

Type of media/ Logo	Remarks	Indicated as
	High quality movie and music discs	DVD-V
	Music discs with video Including SVCD (Conforming to IEC62107)	VCD
	Music discs	CD

Note about using a DualDisc

The digital audio content side of a DualDisc does not meet the technical specifications of the Compact Disc Digital Audio (CD-DA) format so playback may not be possible.



Discs that cannot be played

Blu-ray Discs, HD DVD, AVCHD discs, DVD-RW version 1.0, DVD-Audio, DVD-ROM, DVD-VR, CD-ROM, CDV, CD-G, SACD, DTS Music Discs, WMA discs and Photo CD, DVD-RAM, and "Chaoji VCD" available on the market including CVD, DVCD and SVCD that do not conform to IEC62107.

Disc handling precautions

- Do not attach labels or stickers to discs. This may cause disc warping, rendering it unusable.
- Do not write on the label side with a ball-point pen or other writing instrument.
- Do not use record cleaning sprays, benzene, thinner, liquids which prevent static electricity, or any other solvent.
- Do not use scratch-proof protectors or covers.
- Do not use the following discs:
 - Discs with exposed adhesive from removed stickers or labels (rented discs, etc.).
 - Discs that are badly warped or cracked.
 - Irregularly shaped discs, such as heart shapes.

Recorded discs and USB devices

Type of media/ Logo	Formats	Indicated as
	<ul style="list-style-type: none"> • DVD-Video Format • MP3 format • JPEG format • DivX® format 	DVD-V MP3 JPEG DivX
	<ul style="list-style-type: none"> • DVD-Video Format • DivX® format 	DVD-V DivX
+R/+RW/+R DL	• +VR (+R/+RW Video Recording) Format	DVD-V
CD-R/RW	<ul style="list-style-type: none"> • CD-DA format • MP3 format • JPEG format • DivX® format 	CD MP3 JPEG DivX
USB device	<ul style="list-style-type: none"> • MP3 format • JPEG format • DivX® format 	MP3 JPEG DivX

- Before playback, finalise the disc on the device it was recorded on.
- It may not be possible to play all the above-mentioned medias in some cases due to the type of media, the condition of the recording, the recording method, or how the files were created (About MP3/ JPEG/DivX files).
- During playback of DTS source, there will be no sound from the speakers.

5.2.2. File Extension Type Support (MP3/JPEG/DivX)

<p>MP3 (Extension: “.MP3”, “.mp3”)</p> <ul style="list-style-type: none">● Sampling frequency and compression rate:<ul style="list-style-type: none">– 8 kHz, 11.02 kHz, 12 kHz, 16 kHz, 22.05 kHz, 24 kHz (8 kbps to 160 kbps), 32 kHz, 44.1 kHz and 48 kHz (32 kbps to 320 kbps)● ID3 tags: version 1, 2
<p>JPEG (Extension: “.JPG”, “.jpg”, “.JPEG”, “.jpeg”)</p> <ul style="list-style-type: none">● JPEG files taken on a digital camera that conform to DCF Standard (Design rule for Camera File system) Version 1.0 are displayed.<ul style="list-style-type: none">– Files that have been altered, edited or saved with computer picture editing software may not be displayed.● This unit cannot display moving pictures. MOTION JPEG and other such formats, still pictures other than JPEG (e.g. TIFF), or play pictures with attached audio.
<p>DivX (Extension: “.DIVX”, “.divx”, “.AVI”, “.avi”)</p> <ul style="list-style-type: none">● DivX files greater than 2 GB or have no index may not be played properly on this unit.● This unit supports all resolutions up to maximum of 720×480 (NTSC)/720×576 (PAL).

- There may be differences in the display order on the menu screen and computer screen.
- This unit cannot play files recorded using packet write.

DVD-R/RW

- Discs must conform to UDF bridge (UDF 1.02/ISO9660).
- This unit does not support multi-session. Only the default session is played.

CD-R/RW

- Discs must conform to ISO9660 level 1 or 2 (except for extended formats).
- This unit supports multi-session but if there are many sessions it takes more time for play to start. Keep the number of sessions to a minimum to avoid this.

USB device

- This unit does not guarantee connection with all USB devices.
- This unit does not support USB device charging.
- FAT12, FAT16 and FAT32 file systems are supported.
- This unit supports USB 2.0 Full Speed.

5.3. DivX Information

ABOUT DIVX VIDEO:

DivX® is a digital video format created by DivX, LLC, a subsidiary of Rovi Corporation. This is an official DivX Certified® device that plays DivX video.

Visit divx.com for more information and software tools to convert your files into DivX videos.

ABOUT DIVX VIDEO-ON-DEMAND:

This DivX Certified® device must be registered in order to play purchased DivX Video-on-Demand (VOD) movies.

To obtain your registration code, locate the DivX VOD section in your device setup menu.

Go to vod.divx.com for more information on how to complete your registration.

Display the unit's registration code

("DivX Registration" in Others menu)

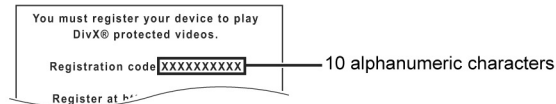

- After playing DivX VOD content for first time, "DivX Registration" is not selectable until this unit is deregistered.
- If you purchase DivX VOD content using a registration code different from this unit's code, you will not be able to play this content.

Cancel the unit's registration

Select "DivX Deregistration" and follow the on-screen instructions.

Use the deregistration code to cancel the registration in <http://vod.divx.com>.

Regarding DivX content that can only be played a set number of times

Some DivX VOD contents can only be played a set number of times. When you play this content, the number of times already played and initially playable number of times is displayed.

- The remaining number of plays decreases each time a programme is played. However, when playing from the point where play was previously stopped, the remaining number of plays does not decrease due to the resume play function.

6 Location of Controls and Components

6.1. Remote Control Key Button Operations

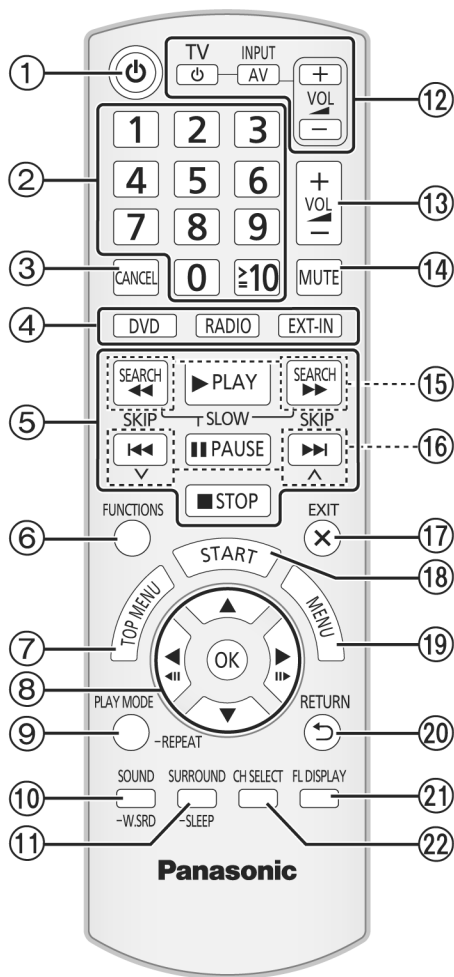

- ① Turn the main unit on/off
- ② Select channels and title numbers etc. / Enter numbers
- ③ Cancel
- ④ **Source select**
 [DVD]: Select disc as the source
 [RADIO]: Select FM tuner
 [EXT-IN]: Select external audio as the source
 AUX → D-IN → USB
- ⑤ Basic operations for play
- ⑥ Show on-screen menu
- ⑦ Show a disc top menu
- ⑧ Select or confirm menu items / Frame-by-frame
- ⑨ Select the play mode / Set the repeat mode
- ⑩ Select sound mode / Turn Whisper-mode Surround on/off
- ⑪ Select surround sound effects
 or
Set the Sleep timer
 Press and hold [-SLEEP].
 While the time is shown on the main unit's display, press [-SLEEP] repeatedly.
 Each time you press the button:
 SLEEP 30 → SLEEP 60 → SLEEP 90 → SLEEP120
 OFF (Cancel)
- To confirm the remaining time, press and hold the button again.
- ⑫ **TV operations**
 Aim the remote control at the Panasonic TV and press the button.
 [TV, ⏻]: Turn the TV on/off
 [INPUT, AV]: Change the TV's video input mode
 [+ , VOL, -]: Adjust the TV volume
 This may not work properly with some models.
- ⑬ Adjust the volume of the main unit
- ⑭ **Mute the sound**
 - "MUTE" flashes on the main unit's display while the function is on.
 - To cancel, press the button again or adjust the volume.
 - Muting is cancelled when you switch the unit to standby.
- ⑮ Select radio stations manually
- ⑯ Select preset radio stations
- ⑰ Exit the display
- ⑱ Show START menu
- ⑲ Show a disc menu
- ⑳ Return to previous screen
- ㉑ Switch information on the main unit's display
- ㉒ Select speaker channel

6.2. Main Unit Key Button Operations

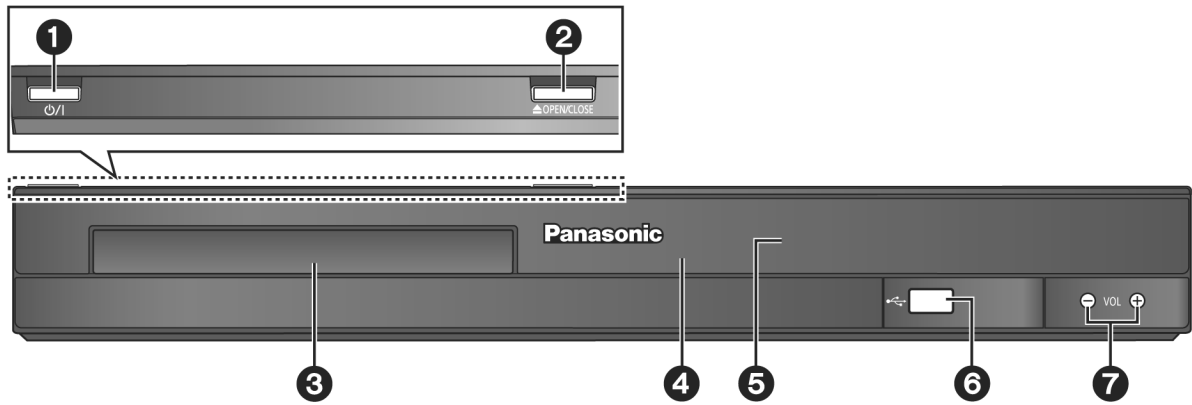

1 Standby/on switch (⏻/⏻)

Press to switch the unit from on to standby mode or vice versa. In standby mode, the unit is still consuming a small amount of power.

2 Open/Close the disc tray

3 Disc tray

4 Remote control signal sensor

5 Display (FL display)

6 Connect USB device

7 Adjust the volume of the main unit

7 Installation Instructions

Turn off all equipment before connection and read the appropriate operating instructions.
Do not connect the AC power supply cord until all other connections are completed.

7.1. Speaker Connections

Cable type	Speakers	A	B
(Attached to subwoofer)	Subwoofer	6	SUBWOOFER / ENCEINTE D'EXTRÊMES-GRAVES
Short	Center speaker	5	CENTER / CENTRE
	Front speaker (R)	2	FRONT / AVANT
	Front speaker (L)	1	
Long	Surround speaker (R)	4	SURROUND / AMBIOPHONIE
	Surround speaker (L)	3	

Use of the speaker cable stickers is convenient when making cable connections.

e.g., Surround speaker (L)

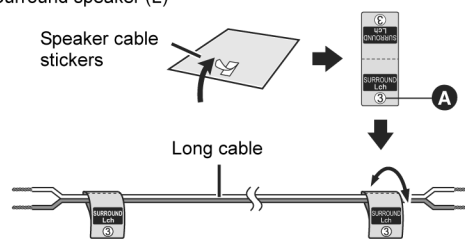

Verify the type of speaker with the label on the speaker before connecting the appropriate cable.

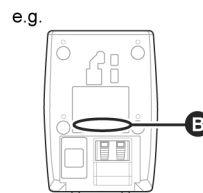

Connect the speaker cables to the appropriate speakers by referring to the above table.

Insert the wire fully, taking care not to insert beyond the wire insulation.

Be careful not to cross (short circuit) or reverse the polarity of the speaker wires as doing so may damage the speakers.

+: White
 -: Blue line

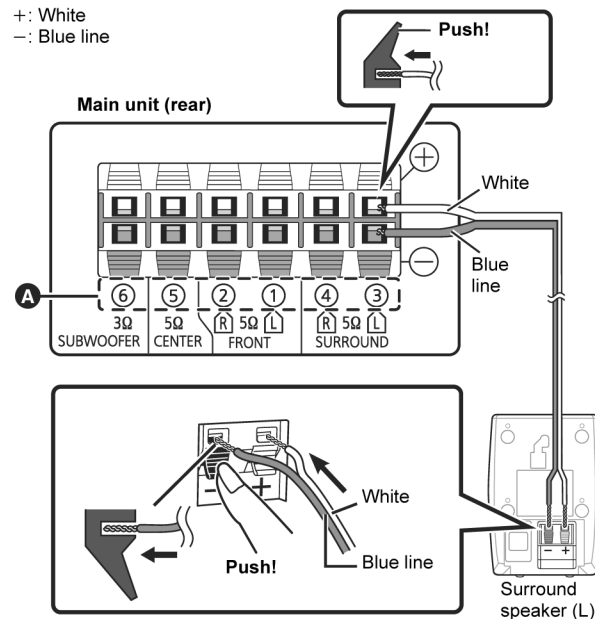

7.2. Radio Antenna Connection

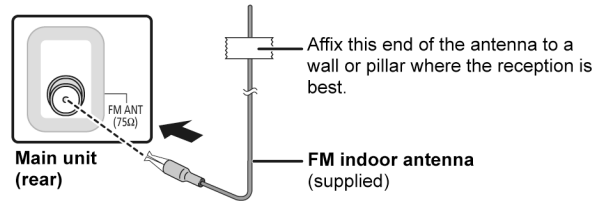

Use an FM outdoor antenna if radio reception is poor.

8 Operating Instructions

8.1. Removing of disc during abnormality

8.1.1. Using main unit key buttons.

8.1.1.1. When the power can be turned off.

1. Turn off the power and press & hold [OPEN/CLOSE] button on main unit and [SKIP FWD] button on remote for 5 seconds

8.1.1.2. When the power cannot be turned off

1. Press & hold the [POWER] button to turn off the power forcibly, then press & hold [SKIP FWD] button on remote and [OPEN/CLOSE] button on main unit for 5 seconds.

8.1.2. When the Forcible Disc Eject cannot be done.

1. Turn off the power and remove AC cord.
2. Insert Paper Clip into the hole on the bottom of unit and slide the Paper Clip on the direction of the arrow to eject tray slightly. The tray will open automatically.

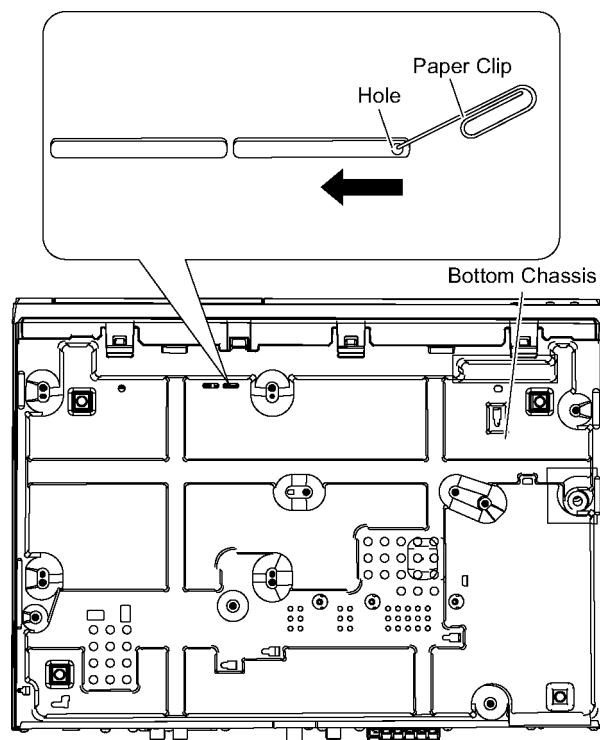

3. Gently pull out the tray.
4. Remove the disc

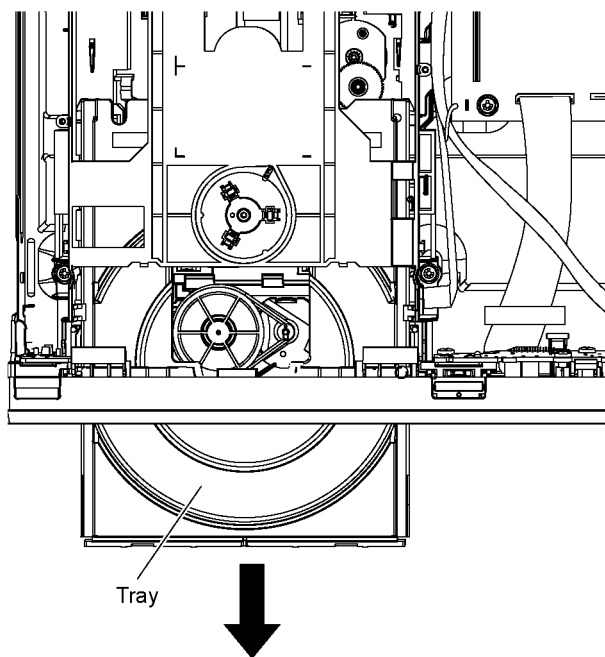

9 Service Mode

9.1. Cold-Start

Here is the procedure to carry out cold-start for initialize to shipping mode.

1. Unplug AC power cord
2. Press & hold [⏻/|] button
3. Plug AC power cord while [⏻/|] button being pressed
FL Display will show “-----”
4. Release [⏻/|] button

9.2. Panel Code Setting Operation

9.2.1. Checking of Panel Code

1. In STOP (no disc) mode, press [OPEN/CLOSE] button on main unit, and [6] button on the remote control unit.

FL Display:

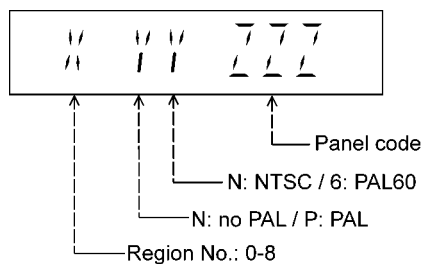

Display is automatically clear after 5 seconds.

Note: Refer to Figure 9.2.1 for "Video Design Information".

Series Code	Country	DVD Region Code	TV Broadcasting System	Product			
				Selected TV System	Region Display (Default)	OSD Default	OSD Menu Language
P, PC, PX, PP	USA, Canada, US Military	1	NTSC	AUTO2 (*A)	1PN	English	English (NA), Spanish (NA), Canadian French
(blank)	Japan	2	NTSC	AUTO2 (*A)	2PN	Japanese	Japanese, English
EP	Poland, E.Europe	2	PAL	PAL (*C)	2PP	English	English (EU), French, German, Spanish (EU), Polish, Russian, Czech, Hungarian
EB, EG,	UK, Germany, W.Europe	2	PAL	PAL (*C)	2PP	English	English (EU), French, German, Italian, Spanish (EU), Polish, Swedish, Dutch
GC, GS	Middle East, Africa, S.E.A	2	PAL	PAL (*C)	2PP	English	English (NA), French, German, Spanish (EU), Polish, Russian, Czech, Hungarian
GA, GD, GJ	South East Asia, Korea	3	PAL /NTSC	Auto (*B)	3PN	English	English (NA), Traditional Chinese
GT	Taiwan	3	PAL /NTSC	NTSC (*E)	3PN	Traditional Chinese	English (NA), Traditional Chinese
GN	New Zealand, Australia	4	PAL	PAL (*C)	4PP	English	English (EU), French, German, Italian, Spanish (EU), Polish, Swedish, Dutch
PN	Central & S.America, Brazil	4	NTSC	NTSC (*D)	4PN	Spanish	English (NA), Spanish (Panama), French, Brazilian Portuguese
PB	Central & S.America, Brazil	4	NTSC	NTSC (*D)	4PN	Portuguese	English (NA), Spanish (Panama), French, Brazilian Portuguese
PU,PH, PR	South/Central America, Argentina	4	NTSC	NTSC (*D)	4PN	English	English (NA), Spanish (Panama), French, Brazilian Portuguese
EE	CIS	5	SECAM	PAL (*C)	5PP	English	English (EU), French, German, Spanish (EU), Polish, Russian, Czech, Hungarian
GW	India	5	PAL	PAL (*C)	5PP	English	English (NA), Traditional Chinese
GK	China	6	PAL	Auto (*B)	6PN	Simplified Chinese	English (NA), Simplified Chinese

NA: North America, EU: Europe

Auto2 (*A) ※ = default

Select TV System		No
TV sys	Source	Output
PAL	--	--
NTSC	--	--
Auto	--	--
Auto2 ※	NTSC	NTSC
	PAL DVD-V	PAL
	PAL VCD	NTSC

Wallpaper = NTSC

Auto (*B) ※ = default

Select TV System		Yes
TV sys	Source	Output
PAL	PAL / NTSC	PAL
NTSC	PAL / NTSC	NTSC
Auto ※	PAL / NTSC	same as source
Auto2	--	--

Wallpaper = NTSC

PAL (*C) ※ = default

Select TV System		Yes
TV sys	Source	Output
PAL ※	PAL / NTSC	PAL
NTSC	PAL / NTSC	NTSC
Auto	PAL / NTSC	same as source
Auto2	--	--

Wallpaper = PAL

NTSC (*D) ※ = default

Select TV System		No
TV sys	Source	Output
PAL	--	--
NTSC ※	PAL / NTSC	NTSC
Auto	--	--
Auto2	--	--

Wallpaper = NTSC

NTSC (*E) ※ = default

Select TV System		No
TV sys	Source	Output
PAL	PAL / NTSC	PAL
NTSC ※	PAL / NTSC	NTSC
Auto	PAL / NTSC	same as source
Auto2	--	--

Wallpaper = NTSC

Explanation of Display



Individual Model Code

{ N: If NTSC disc is played, NTSC output.
P: If PAL disc is played, PAL output.

Can play PAL disc

Region code

Figure 9.2.1

9.2.2. Setting of Panel Code

Step 1 Press [OPEN/CLOSE] button on main unit, follow by [4] and [7] on remote control (to enter Doctor Mode).

Step 2 Press [CANCEL] button on remote control, then press [2], [2], [8] and [0] on remote control.

Step 3 Key in new panel code using remote control (refer to Figure 9.2.2).

Step 4 Press [OK] on remote control.

Step 5 Unplug AC power cord.

Step 6 Plug AC power cord.

Step 7 Press [⏻/⏪] button on main unit.

Step 8 Check panel code (refer to section 9.2.1).





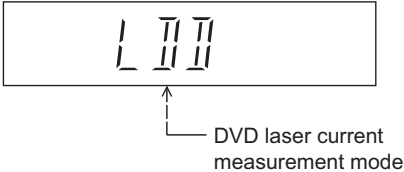
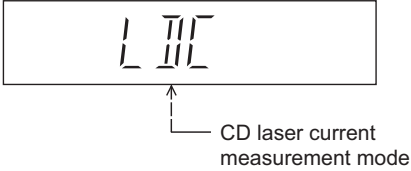

Main P.C.B. Part No.		REP4756AT	REP4756BT	REP4756CT	REP4756DT
Default Code		200	261	221	161
Support Model Panel Code	XH20GA				160
	XH20GC				170
	XH20GK				190
	XH20GW				161
	XH20PH				180
	XH20PR				180
	XH70EB			220	
	XH70EE		230		
	XH70EG			221	
	XH70EP			222	
	XH70GA		260		
	XH70GN		240		
	XH70GS		270		
	XH70GW		261		
	XH70P	200			
	XH70PC	201			
	XH70PH		280		
	XH70PR		280		
	XH73GA		360		
	XH75EP			422	
XH75GA		460			
XH75GK		490			
XH75GS		470			
XH75GT		450			

Figure 9.2.2



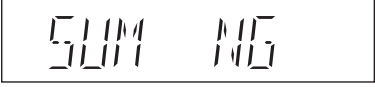

9.3.2. Self Diagnostic Table 2 (For DVD)

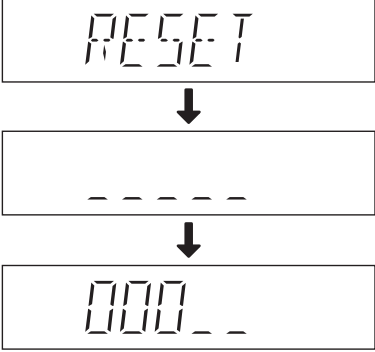
Item		FL Display	Key Operation
Mode Name	Description		Front Key
DVD laser drive current measurement	DVD laser drive current measurement. For DVD laser drive current, refer to Troubleshooting Guide (Section 10.2)	 <p>The value denotes the current in decimal notation.</p>	<p>In STOP (no disc) mode, press [OPEN/CLOSE] button on the main unit, and [FUNCTIONS] button on the remote control unit.</p> <p>To exit, press [OPEN/CLOSE] button on the main unit and [CANCEL] button on the remote control unit.</p>
CD laser drive current measurement	CD laser drive current measurement. For CD laser drive current, refer to Troubleshooting Guide (Section 10.2)	<p>(Display 1)</p> 	<p>In STOP (no disc) mode, press [OPEN/CLOSE] button on the main unit, and [3] button on the remote control unit.</p> <p>To exit, press [OPEN/CLOSE] button on the main unit and [CANCEL] button on the remote control unit.</p>

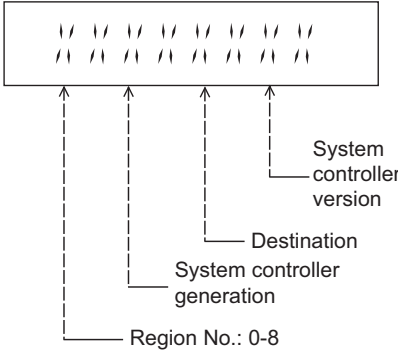
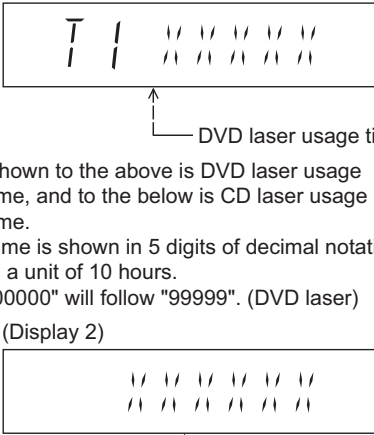

9.3.3. Self Diagnostic Table 3 (For DVD)

Item		FL Display	Key Operation
Mode Name	Description		Front Key
Micro-processor firmware version display & EEPROM checksum display.	<p>Micro-processor firmware version display & EEPROM checksum display. EEPROM checksum is only available due to existence of EEPROM IC.</p> <p>Note: Condition 1/2/3 shows the state of EEPROM IC.</p> <p>FL Display sequence: Display 1→2→3.</p>	<p>(Display 1)</p>  <p>Opecon Version</p> <p>(Display 2)</p>  <p>Syscon Version</p> <p>(Condition 1)</p>  <p>If the version of the EEPROM does not match, [NG] is displayed.</p> <p>(Condition 2)</p>  <p>(a) If there is NO EEPROM header string OR (b) If there is no EEPROM (no data is received by Micro-processor), [NO] is displayed.</p> <p>(Condition 3)</p>  <p>If the EEPROM version matches, checksum [YYYY] is displayed.</p> <p>(Display 3)</p>  <p>Opecon Version EEPROM Checksum (If applicable, refer below.)</p>	<p>In STOP (no disc) mode, press [OPEN/CLOSE] button on the main unit, and [7] button on the remote control unit.</p> <p>Cancelled automatically 5 seconds later.</p> <p>Press [FL Display] button on remote control unit for next page. (FL Display)</p>
Reset	<p>User settings are cancelled and player is initialized to factory setting. It is necessary when after replacement of Micro-processor IC (IC200), FLASH ROM IC (IC8651) & Main P.C.B.</p>		<p>In STOP (no disc) mode, press [OPEN/CLOSE] button on the main unit, and [≥10] button on the remote control unit.</p>

9.3.4. Self Diagnostic Table 4 (For DVD)



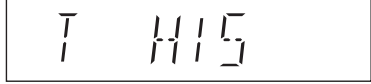

Item		FL Display	Key Operation
Mode Name	Description		Front Key
Region and Firmware version display	DVD firmware version is displayed on the FL Display. Note: It is necessary to check for firmware version before carrying out the version up using the disc.	 <p>Region No.: 0-8 System controller generation Destination System controller version</p>	In STOP (no disc) mode, press [OPEN/CLOSE] button on the main unit, and [8] button on the remote control unit. Cancelled automatically 5 seconds later.
Timer 1 check	Timer 1 check Laser operation timer is measured separately for DVD laser and CD laser. FL Display sequence: Display 1→2.	<p>(Display 1)</p>  <p>DVD laser usage time CD laser usage time</p> <p>Shown to the above is DVD laser usage time, and to the below is CD laser usage time. Time is shown in 5 digits of decimal notation in a unit of 10 hours. "00000" will follow "99999". (DVD laser)</p> <p>(Display 2)</p> <p>Time is shown in 6 digits of decimal notation in a unit of 10 hours. "000000" will follow "999999". (CD laser)</p>	In STOP (no disc) mode, press [OPEN/CLOSE] button on the main unit, and [▲] button on the remote control unit. Cancelled automatically 5 seconds later. Press [FL Display] button for next page of FL Display.
Timer 1 reset	Timer 1 reset Laser operation timer of both DVD laser and CD laser is reset all at once.	 <p>Time is shown in 5 digits of decimal notation in a unit of 10 hours. It will clear to "00000" upon reset.</p>	While displaying Timer 1 data, press [OPEN/CLOSE] button on the main unit, and [▼] button on the remote control unit. Cancelled automatically 5 seconds later
Timer 2 check	Timer 2 check Spindle motor operation timer	 <p>Time is shown in 5 digits of decimal notation in a unit of 1 hour. "00000" will follow "99999".</p>	In STOP (no disc) mode, press [OPEN/CLOSE] button on the main unit, and [▶] button on the remote control unit. Cancelled automatically 5 seconds later.
Timer 2 reset	Timer 2 reset Spindle motor operation timer	 <p>Time is shown in 5 digits of decimal notation in a unit of 1 hour. It will be cleared to "00000" upon activating this.</p>	While displaying Timer 2 data, press [OPEN/CLOSE] button on the main unit, and [◀] button on the remote control unit. Cancelled automatically 5 seconds later.

9.3.5. Self Diagnostic Table 5





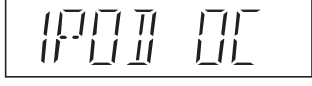

Item		FL Display	Key Operation
Mode Name	Description		Front Key
Self-Diagnostic Mode	To enter into self-diagnostic checking		Press & hold [OPEN/CLOSE] on main unit, follow by [4] then [9] on remote control. (When no disc in tray)
Error code information	System will perform a check on any unusual/error code from the memory	Error code will display Example: 	In self-diagnostic mode, press [OPEN/CLOSE] on remote control. To exit, press [⏻ /] on main unit or remote control.
Delete Error Codes	System will clear all of the contents of unusual/error code from the memory		In self-diagnostic mode, press [CANCEL] on remote control. To exit, press [⏻ /] on main unit or remote control.

9.4. Error Code

9.4.1. Error Code Table 1

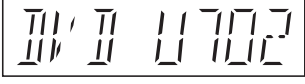
Error Code	Diagnosis Contents	Description of error	Automatic FL Display	Remarks
F61	The abnormalities in the Power Amp output or power supply	In normal operation, when DCDET2 goes to L, immediately PCNT is set to L (not normal POWER OFF sequence), and Error Code F61 is displayed, without displaying 'GOODBYE' scroll on the FL. When happen error, it memorizes the contents and displays unusual contents in self-diagnostic error detection mode.		Press [OPEN/CLOSE] on main unit for next error.
F76	Abnormality in the output voltage of stabilized power supply	In normal operation when DCDET1 is detected L(Low) for two consecutive times, F76 is displayed on FL for 1 seconds and after that PCONT will be turned to L (Low).		Press [OPEN/CLOSE] on main unit for next error.
IPOD OVER CURRENT	Over current occurs in Power Supply for iPod charging	In normal operation when IPOD_OC is detected "L" (Low) for two consecutive times, the message will display on FL once and Power Supply to iPod shall be cut.		Power off the main unit and power on again.
F0C1	Disc Region	DVD: Prohibited by the restricted region code.		
F0C3		DVD: Parental lock setting prohibits the playback of the entire title.		

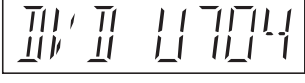
9.4.2. Error Code Table 2

Error Code	Diagnosis Contents	Description of error	Automatic FL Display	Remarks
H01	Tray loading error	The tray opening and closing is abnormal. CLOSE and OPEN of the tray cannot be carried out properly. Loading motor error, DV5 LSI IC (IC8001) error.		Press [OPEN/CLOSE] on main unit for next error. (OPEN time: OPEN → CLOSE → OPEN → H01 at CLOSE: CLOSE → OPEN → CLOSE H01)
H03	Traverse motor error	The traverse is abnormal. (Traverse servo, DV5 LSI IC (IC8001), TRV motor error.)		Press [OPEN/CLOSE] on main unit for next error.
U11	Focus servo error	Focus coil, FE signal error. Disc may be dirty.		Press [OPEN/CLOSE] on main unit for next error. (Unfinalized DVD-R is likely to become U11.)
U702	HDMI/DVI I2C communication error	HDMI/DVI HDCP non-HDCP compliance: Occurs when the equipment is not compatible with the HDCP receiver. [HDCP: copyright protection technology. Digital image signal encryption scheme.]		Press [OPEN/CLOSE] on main unit for next error.
U703	HDMI/DVI authentication error	When authentication (HDCP) with the TV side fails when connecting it with HDMI/DVI, it is generated.		Press [OPEN/CLOSE] on main unit for next error.
U704	HDMI/DVI SRM error	It is generated at the equipment to which the TV set is connected with HDMI/DVI.		Press [OPEN/CLOSE] on main unit for next error.
U705	HDMI/DVI SRM disk falsification check error	It is generated at the time of it is time when illegal the SRM data of the reproducing disk (verify error), when connecting it with HDMI/DVI.		Press [OPEN/CLOSE] on main unit for next error.
F899	The communication specification disagreement between micro-processor	Unsuitable combination of number of system com and panel com used. (Firmware)		Press [OPEN/CLOSE] on main unit for next error.

9.5. Sales Demonstration Lock Function

This function prevents discs from being lost when the unit is used for sales demonstrations by disabling the disc eject function. "LOCKED" is displayed on the unit, and ordinary operation is disabled.

9.5.1. Setting

• Prohibiting removal of disc

1. Select the DVD/CD function.
2. At POWER ON condition, press and hold down the [**▲**OPEN/CLOSE] button and the [- VOL] button on the main unit for at least three seconds. (The message, "LOCKED" appears when the function is activated.)

Note:

OPEN/CLOSE **▲** button is invalid and the main unit displays "LOCKED" while the lock function mode is entered.

• Prohibiting operation of selector and disc

1. Select the DVD/CD function.
2. At POWER ON condition, press and hold down the [**▲**OPEN/CLOSE] button and the [VOL +] button on the main unit for at least three seconds. (The message, "LOCKED" appears when the function is activated.)

Note:

The following buttons are invalid and the main unit displays "LOCKED" while the lock function mode is entered.

Main unit	▲ OPEN/CLOSE
Remote controller unit	AV/INPUT, NUMERIC KEYS 0-9, ≥ 10 , CANCEL, DVD, RADIO, EXT-IN, ◀◀ , ▶ , ▶▶ , ◀◀◀ , , ▶▶▶ , ■ , FUNCTIONS, EXIT, TOP MENU, ◀ , ▲ , ▶ , ▼ , OK, START, MENU, RETURN, PLAY MODE/-REPEAT, CH SELECT, FL DISPLAY







9.5.2. Cancellation

The lock can be cancelled by the same procedure as used in locking. ("UNLOCKED" is displayed on cancellation)

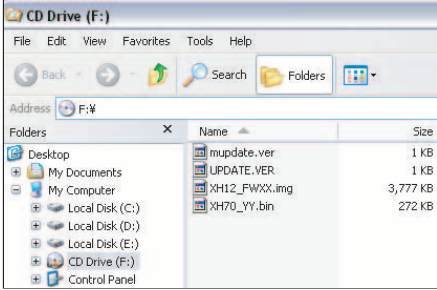
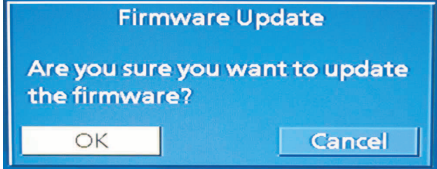
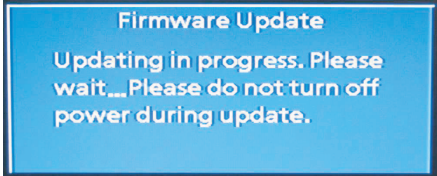

At normal Power ON/OFF the LOCKED condition is not cleared. However, AC Power ON/OFF should clear LOCKED condition.

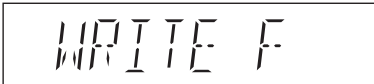
9.6. Firmware Version-Up Information

9.6.1. Process Flow (1/2)

Item		FL/ GUI Display	Remarks
Process	Description		
1	<p>Collect ROM Files (Copy files into CD-R/RW)</p> <p>Step 1 Unzip the firmware update file.</p> <p>Step 2 Burn below files into root folder of the CD disc.</p> <p>Step 3 1. UPDATE.ver 2. XH12_FWXX.img (Where the XX is the version number for firmware) 3. mupdate.ver 4. XH70_YY.bin (Where the YY is the version number for firmware)</p> <p>Notes: 1. Software update files = "mupdate.ver" & "XH70_YY.bin" 2. Firmware update files = "UPDATE.ver" & "XH12_FWXX.img"</p>	<p>Display 1:</p> 	<p>User can put both files into the same root directory. DVD MODEL will choose the right ROM files to update its firmware.</p>
2	<p>Load disc into unit (To update rate)</p> <p>Step 1 Power on main unit.</p> <p>Step 2 Change selector to DVD/CD mode (default is CD/DVD mode)</p> <p>Step 3 Load in the disc with software/firmware update data.</p> <p>➔ After disc reading, GUI will display as: "GUI Display 1.1: Are you sure you want to update the firmware?"</p> <p>Step 4 Use remote control to select "OK" button and press remote control [OK] key.</p> <p>➔ Wait about 15~20 min to finish update process.</p> <p>➔ After disc reading, GUI will display as: "GUI Display 1.2: Updating in progress. Please wait...Please do not turn off power during update."</p> <p>➔ FL will display in the sequence of "WRITE C", "WRITE D", "WRITE E", "WRITE F" and "WRT ROM2" as FL display 1.1~1.5 shown.</p>	<p>GUI Display 1.1:</p>  <p>GUI Display 1.2:</p>  <p>FL Display 1.1:</p>  <p>FL Display 1.2:</p>  <p>FL Display 1.3:</p>  <p>FL Display 1.4:</p>  <p>FL Display 1.5:</p> 	<p>All panel keys and remote controller keys, including [⏻ /] key, are invalid during CD Update.</p> <p>Caution: Make sure the power supply during CD update. If the power supply cable is unplugged during update stage, CD update will fail. The DVD model can't work, and can't be recovered by CD update again.</p>

9.6.2. Process Flow (2/2)

Item		FL/ GUI Display	Remarks
Process	Description		
	<p>Update Completed</p> <ul style="list-style-type: none"> If firmware software update completes successfully: <p>➔ <i>GUI Display 1.3:</i> "Firmware update is completed, please open the tray and remove the disc."</p> <p>➔ <i>FL Display (Main Unit) will display "GOOD" as "FL Display 1.6" shown.</i></p> <p>Step 5 Eject the disc and power off main unit.</p> <p>Step 6 Power on the unit and do system initialize.</p> <p>Step 7 Update process finish.</p>	<p>GUI Display 1.3:</p>  <p>FL Display 1.6:</p> 	<p>To initialize, press and hold main unit [OPEN/CLOSE] then press remote control key [≥ 10].</p>

10 Troubleshooting Guide

10.1. Troubleshooting Guide for F61 and/or F76

This section illustrates the checking procedures when upon detecting the error of “F61” and/or “F76” after power up of the unit. It is for purpose of troubleshooting and checking in SMPS P.C.B..

Symptom(s)	Checking items	Possible Fault(s)	Remarks
Set cannot Power ON: Condition 1: With Standby LED on Condition 2: With Standby LED Off or flickering	1 Regulator IC IC2900	1 Faulty IC2900 (No +12V output)	1) Refer to Fig. 1. SMPS P.C.B. 2) Refer to Schematic Diagram of SMPS Circuit (Item 17.5)
	1 AC cord	1 Faulty AC cord, loose connection	
	2 AC Inlet P5701 3 Fuse F1	2 P5701 solder crack, dry joint etc 3 F1 Fuse open	
Set can Power ON then F61	1 Transformer T5701	1a Pin 14/15 shorted to pin 12/13	Refer to Schematic Diagram of SMPS Circuit (Item 17.5) for terminal pin count on primary and secondary terminals
		1b Fan unit defective	
	2 Photocoupler PC701	2 Solder crack, dry joint, short circuit, open circuit, etc	Refer to Fig. 1. SMPS P.C.B.
Set can Power ON then F76	1 DC-DC circuit	1a Loose connection at CN100 (No +23V) check cable connection between CN100 & H2016	1) Refer to Fig. 2. Main P.C.B. 2) Refer to Schematic diagram of Main Circuit (Item 17.3)
		1b No +6V voltage output at pin3, IC106	
		1c L125 open	
		1d Q100 faulty (No +5V voltage output at pin1, 2, 5 & 6)	
		1e Q107 & D114 faulty (No +9V voltage)	
		1f IC107 faulty (No +3.3V voltage output at pin1)	
		1g K102, K105, K304 open (+3.3V line going to Panel P.C.B. at CN203)	
	2 Photocoupler PC701	2 Solder crack, dry joint, short circuit, open circuit, etc	Refer to Fig. 1. SMPS P.C.B.
Set can Power ON working normally for sometime then F61	1 Thermal Diode D5706	1a Improper contact between D5706 to heatsink	Refer to Fig. 1. SMPS P.C.B.
		1b OTP (thermal) protection trigger prematurely	

10.1.1. SMPS P.C.B.

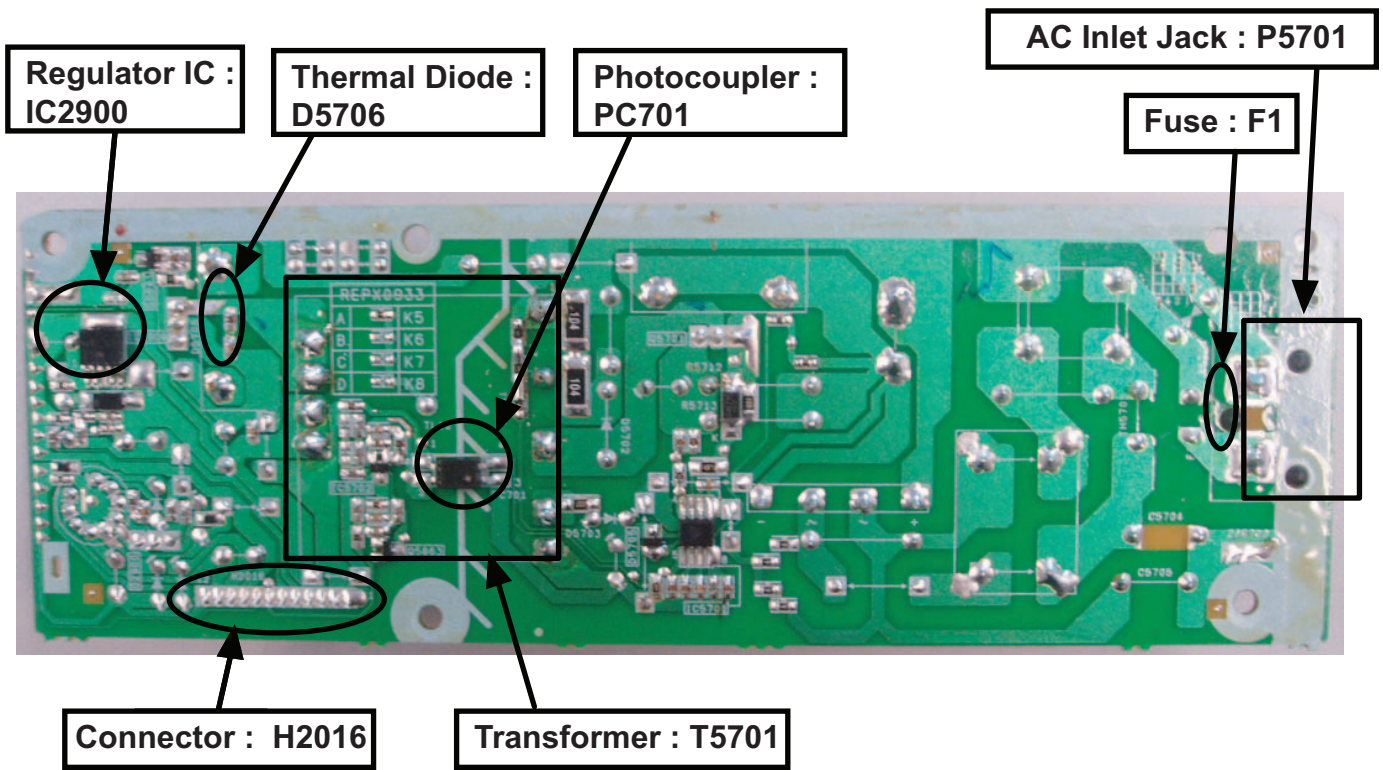
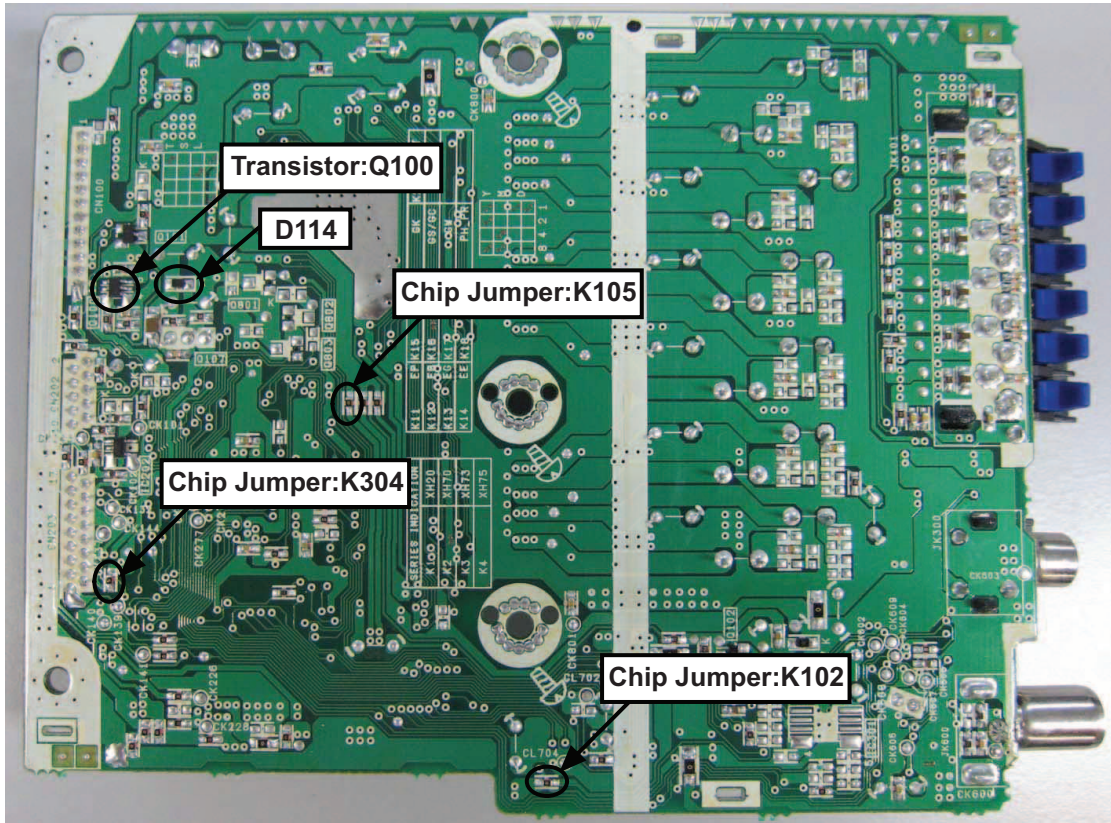

Fig. 1. SMPS P.C.B.

10.1.2. Main P.C.B

(Side A of Main P.C.B.)



(Side B of Main P.C.B.)

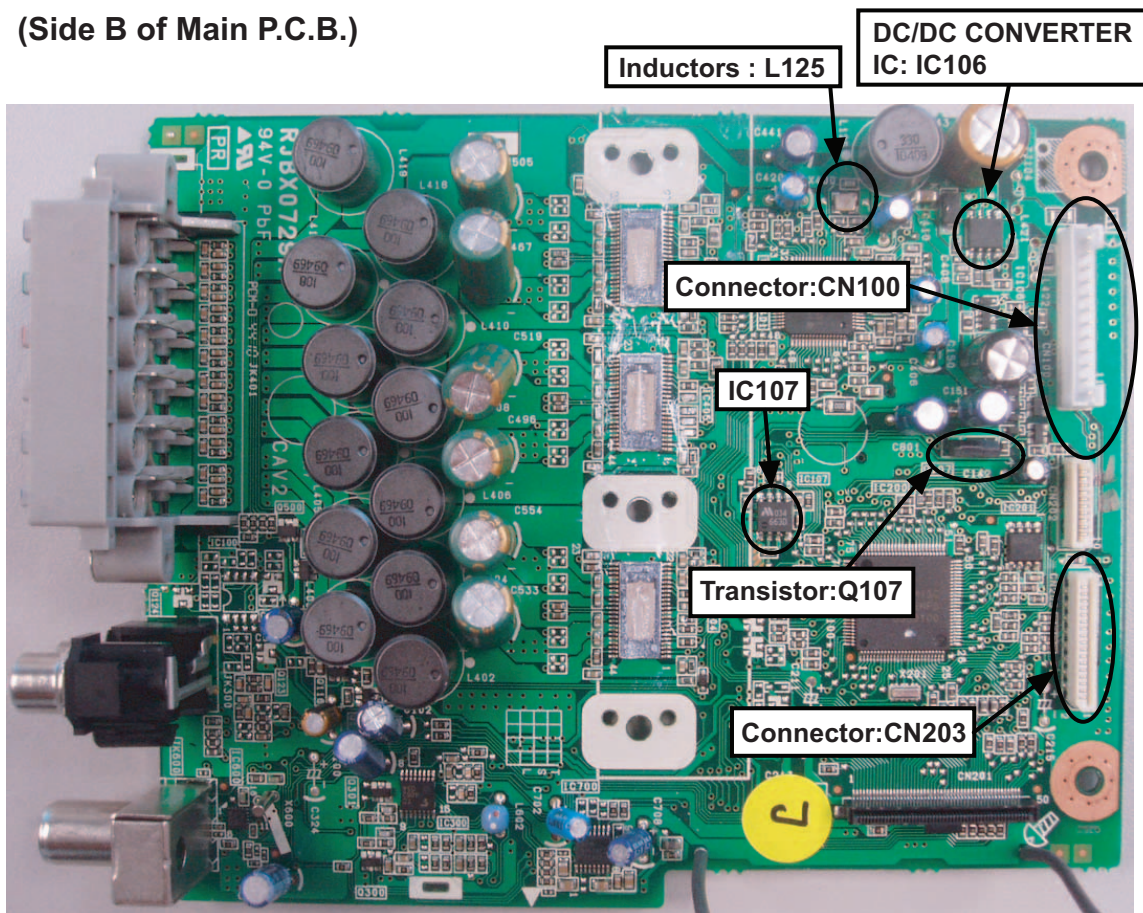

Fig. 2. Main P.C.B.

10.2. DVD/CD Laser Diode current measurement

This section will illustrate procedures of measuring & deriving DVD/CD Laser Diode Current.

Item Description	Checking Item/Formula	Remarks
CD Laser Diode Current Measurement	<ol style="list-style-type: none">1. Measurement the voltage (V_{CD}) on the testpoints CL8530(+) & CL8531(-). This is voltage across R8566 which has a resistance value of 4.7 ohm.2. Calculate the CD Laser current by the following formula: $CD_LD=VCD/4.7$3. Specification for CD laser current is ≤ 58 mA	Refer to 10.2.1. Backend P.C.B. (Fig. 3. Backend P.C.B.)
DVD Laser Diode Current Measurement	<ol style="list-style-type: none">1. Measurement the voltage (V_{DVD}) on the testpoints CL8530(+) & CL8532(-). This is voltage across R8556 which has a resistance value of 4.7 ohm.2. Calculate the DVD Laser current by the following formula: $DVD_LD=VCD/4.7$3. Specification for DVD laser current is ≤ 58 mA	Refer to 10.2.1. Backend P.C.B. (Fig. 3. Backend P.C.B.)

10.2.1. Backend P.C.B.

(Side A of Backend P.C.B.)

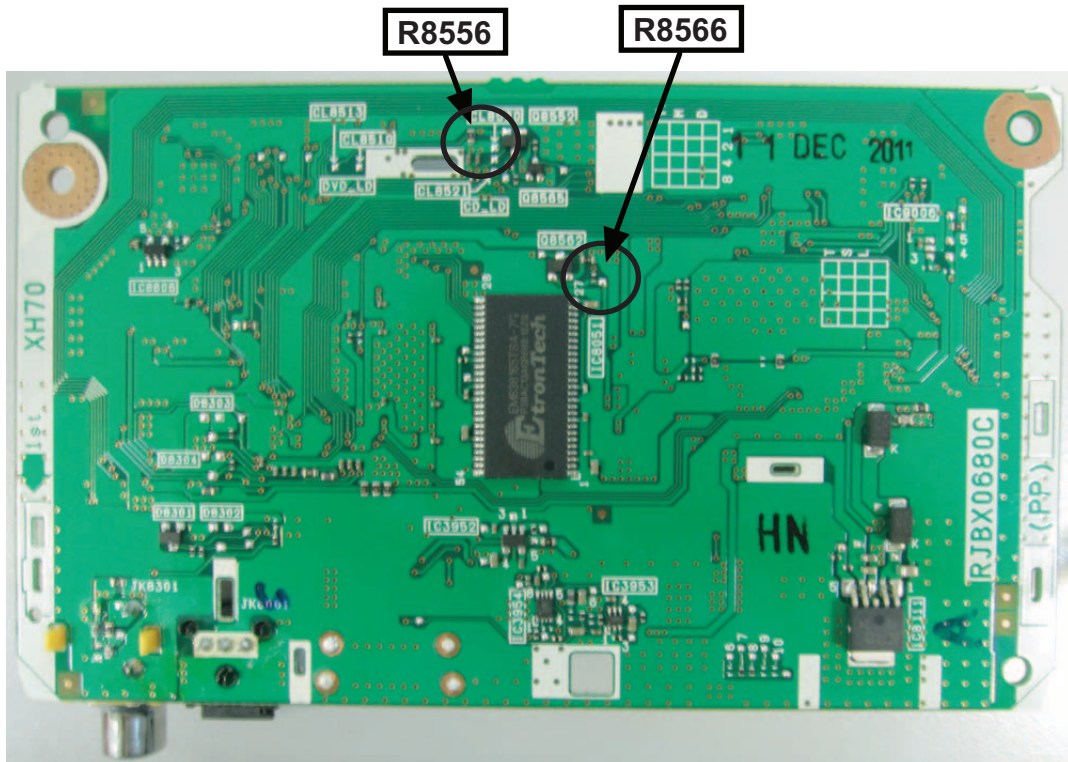

(Side B of Backend P.C.B.)

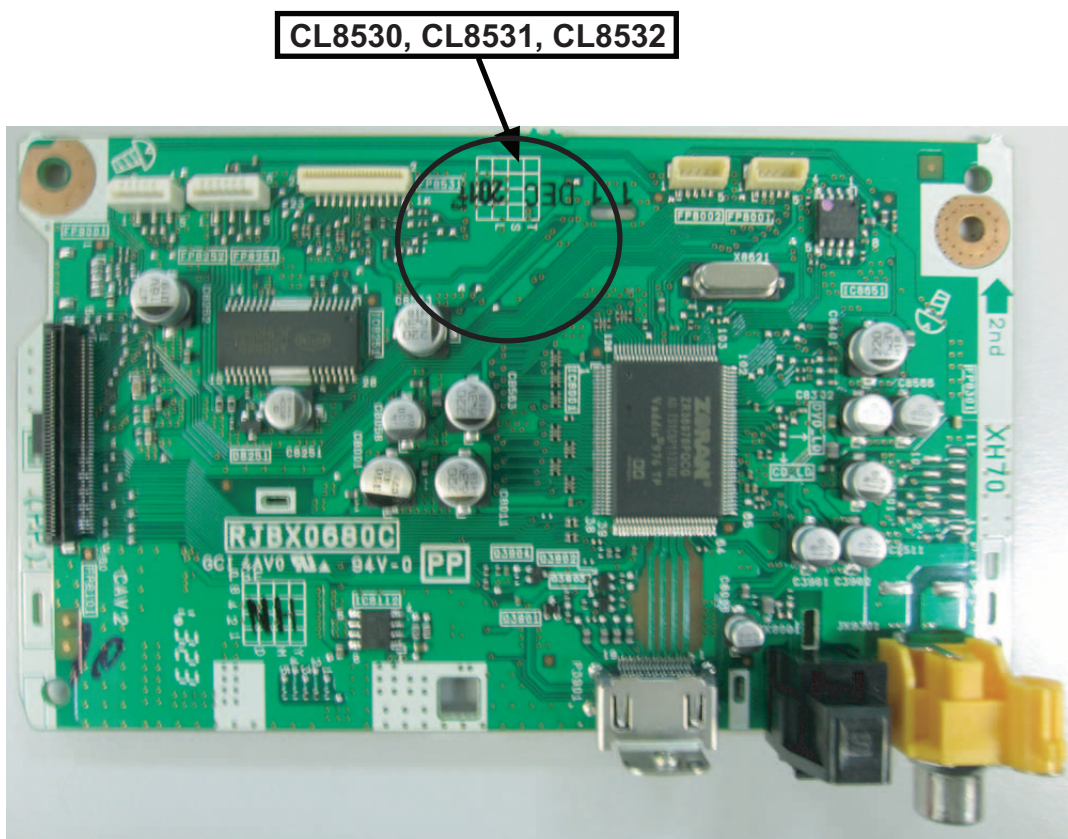

Fig. 3. Backend P.C.B.

10.3. Basic Troubleshooting Guide for Traverse Unit (Backend P.C.B.)

Problems	Checking Points	Checking components
1) Distorted picture or abnormal sound is heard during the initialization	a) Check SDRAM address, data bus, CLK and other control signals waveform	IC8051
	b) Check video signals (CVBS)	LB8317, R8325 (IC8011 Pin 63)
	c) Check audio DAC circuitry * Compare the above with OK condition DVD Module P.C.B	LB8422 till LB8428 *Check for solder short and/or component missing/damaged
2) No TOC/Long TOC	a) Check motor driver circuitry (VCC PVCC)	IC8251 Pin 8, (+9V), 19 (+5V)
	b) Check laser drive circuitry (Voltages & current)	Q8552, CL8532 (For DVD), Q8562, CL8530 (For CD)
	c) Check LSI IC connection to motor drive circuitry	IC8001 Pin 90, 93, 94, 95 IC8251 Pin 11 to 18 * Check for solder short and/or component missing/damaged
3) Disc not spinning 4) Traverse not moving 5) Traverse and spindle abnormal movement	a) Check connection from Main to Traverse unit	FP8251
	b) Check motor driver circuitry on the voltages and control signals	IC8251 * Check for solder short and/or component damaged
6) Cannot read the disc but spindle motor is spinning - Cannot read CD/DVD	a) Check laser drive circuitry (voltages and current) - Check CD Laser Drive - Check DVD Laser Drive * Check voltages and LD current and compare with OK condition Main P.C.B.	Q8552, LB8551 (For DVD Laser Drive current) Q8562, LB8561 (For CD Laser Drive current)
7) Block Noise during play	a) Check SDRAM address and data bus signal	IC8051
8) Jitter out of specification	a) Check LD current b) Check OPU (Change to other unit and confirmed operating condition)	OPU Unit (Traverse unit), FPC connection (FP8531 & FP8251)

10.4. Basic Troubleshooting Guide for HDMI AV output

Problems	Checking Points	Checking components
1) TV does not have any display. Set FL display shows U702/U703	1) Check setting of the set in Setup Menu whether the HDMI Video output is turned ON	* This year HDMI always ON. No need to check Setup Menu. If no resolution selection GUI, then only check SETUP.
	2) +5V Supply to the TV	IC3952 (Pin 4)
	3) HDMI Connector Solderability condition	P3901
	4) HDMI Output TDMS signal lines (IC3901) - Clock (TXCP/TXCN => Pin 50, 49) - Data (TXD0P/TXD0N => Pin 52, 51) - Data (TXD1P/TXD1N => Pin 54, 53) - Data (TXD2P/TXD2N => Pin 56, 55)	HDMI Connector (P3901) - Clock (TXCP/TXCN => Pin 10, 12) - Data (TXD0P/TXD0N => Pin 7, 9) - Data (TXD1P/TXD1N => Pin 4, 6) - Data (TXD2P/TXD2N => Pin 1, 3)
	5) HDMI Transmitter communication lines to TV - Data, DDCCDAT (Pin 46, IC8001) - Clock, DDCCCLK (Pin 47, IC8001)	LB3905, R3905, Q3902, R3904 LB3904, R3907, Q3903, R3906
	6) HDMI Transmitter communication from DVD Decoder (IC8001) +3.3V Supply	LB3901 (Pin 57)
	7) HDMI Transmitter DVD Decoder (IC8001) +1.8 V Supply	LB3902, LB3910, R3910 (Pin 59)
	8) Hot-Plug Signal	LB3906, R3902, R3903, Q3901
	9) HDMI Interface Reference Resistor	R3901
2) When switching the video output mode from 480p to 720p /1080i, TV display become blank	1) Supply to HDMI transmitter intergrated (IC8001) 2) Check for Capacitor short to GND	C8034, C8006, C8029, C8028, LB3901 (Pin 57), LB3902, LB3910 (Pin 59)
3) Error Video Output. TV screen shows green Display	Check Digital Signal Data communication lines from IC8001 to Serial Flash IC (IC8651)	Pin 1, 2, 5, 6 (IC8651) Pin 105, 106, 107, 109 (IC8001)
4) No audio output from HDMI	Check the setting under ' SETUP ' menu if HDMI Audio Output option is turned ' ON '	* Check for solder short/or component missing on TDMS line as well as signal intergrity HDMI Connector (P3901) - Clock (TXCP/TXCN => Pin 10, 12) - Data (TXD0P/TXD0N => Pin 7, 9) - Data (TXD1P/TXD1N => Pin 4, 6) - Data (TXD2P/TXD2N => Pin 1, 3)

11 Service Fixture & Tools

Prepare service tools before process service position.

Ref. No	Service Tools		Remarks
SFT1	Main P.C.B. (CN201) - Backend P.C.B. (FP8101)	RFKZXH150PK2 (50P FFC)	

12 Disassembly and Assembly Instructions

Caution Note:

- This section describes the disassembly and/or assembly procedures for all major printed circuit boards & main components for the unit. (You may refer to the section of “Main components and P.C.B Locations” as described in the service manual)
- Before carrying out the disassembly process, please ensure all the safety precautions & procedures are followed.
- During the disassembly and/or assembly process, please handle with care as there may be chassis components with sharp edges.
- Avoid touching heatsinks due to its high temperature after prolong use. (See caution as described below)

**CAUTION: HOT!!
PLEASE DO NOT
TOUCH THE HEAT SINK**

- During disassembly and assembly, please ensure proper service tools, equipments or jigs is being used.
- During replacement of component parts, please refer to the section of “Replacement Parts List” as described in the service manual.
- Select items from the following indexes when disassembly or replacement are required.
 - Disassembly of Top Cabinet
 - Replacement of Tray Ornament
 - Disassembly of Front Panel Block Assembly
 - Disassembly of Panel P.C.B.
 - Disassembly of Power Button P.C.B.
 - Disassembly of Rear Panel
 - Disassembly of SMPS P.C.B.
 - Replacement of Current Limiting Switch (Q5701)
 - Replacement of Diode (D5706)
 - Disassembly of Main P.C.B.
 - Replacement of Digital Amplifier IC (IC403/IC404/IC405)
 - Disassembly of Backend P.C.B.
 - Disassembly of Component Video P.C.B.
 - Disassembly of DVD Mechanism Unit (BRS1D)
 - Replacement of Traverse Unit.

12.1. Screw Type

CAUTION NOTE:

Please use original screw and at correct locations.

Below shown is part no. of different screw types used:

- | | |
|------------------------|----------------------|
| a :RHD30007-K2J | e :RHD26043-1 |
| b :RHD30119-S | f :XTB3+10JFJ |
| c :RHDX301003 | |
| d :RHD26046 | |

12.2. Disassembly Flow Chart

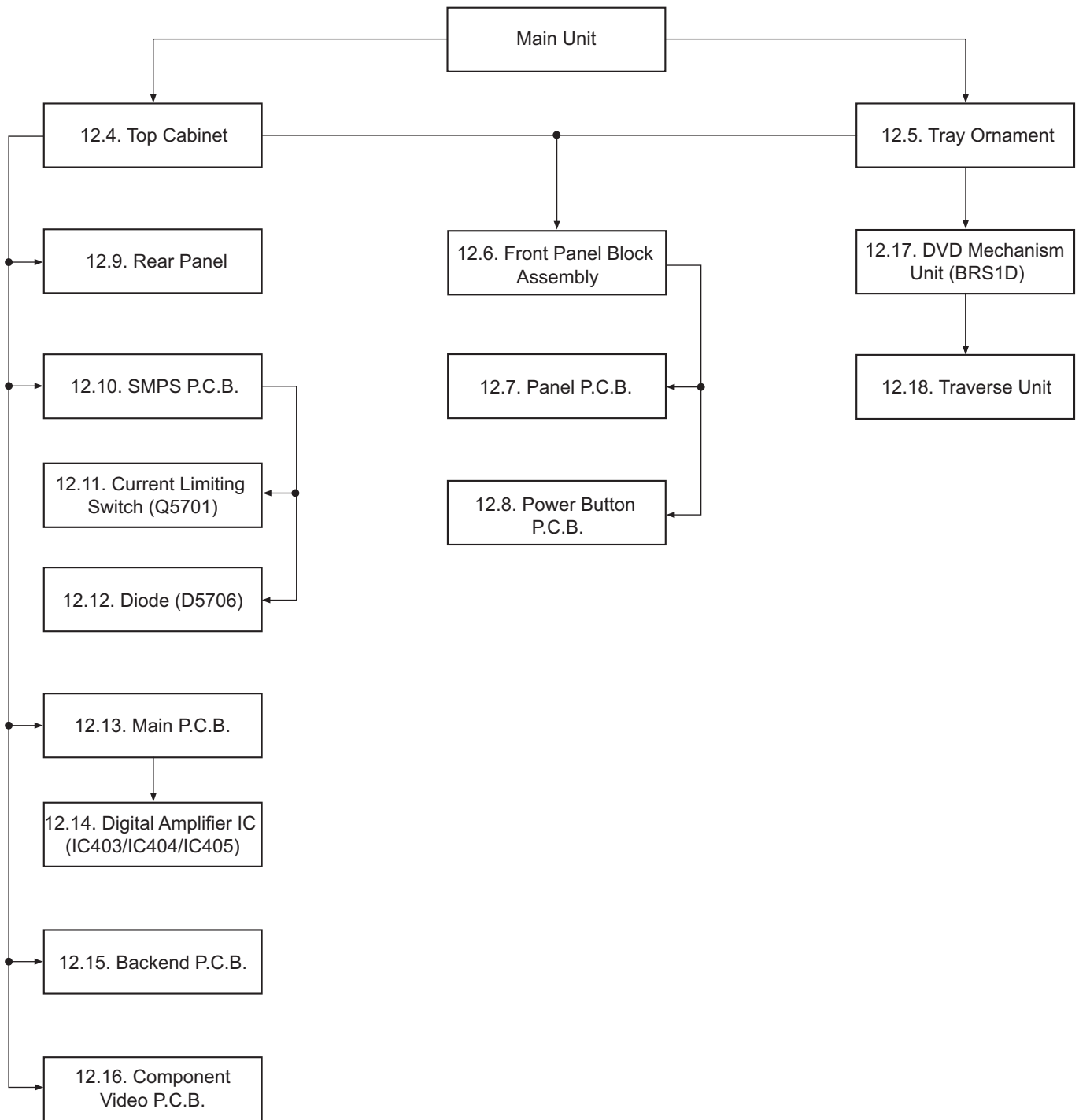

12.3. Main Components and P.C.B. Locations

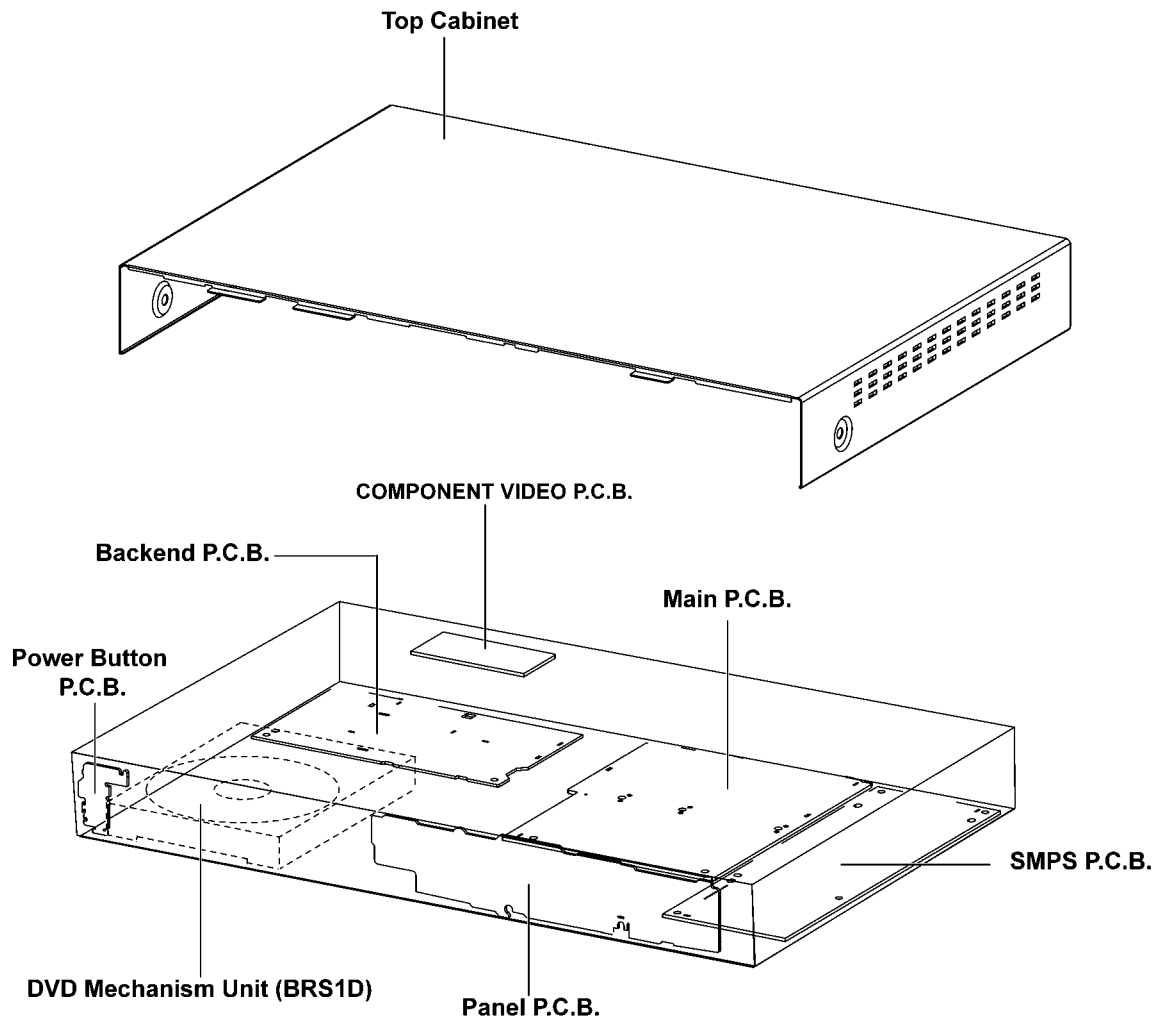

12.4. Disassembly of Top Cabinet

Step 1 Remove 2 screws.

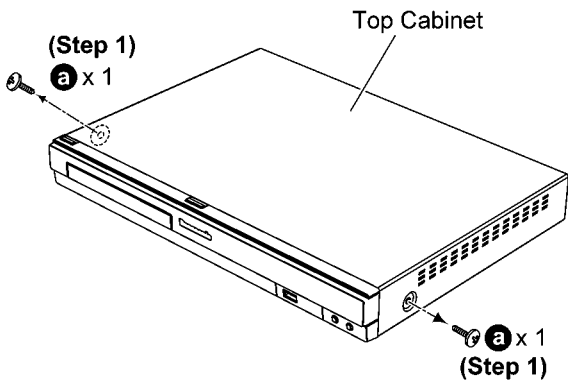

Step 2 Remove 3 screws.

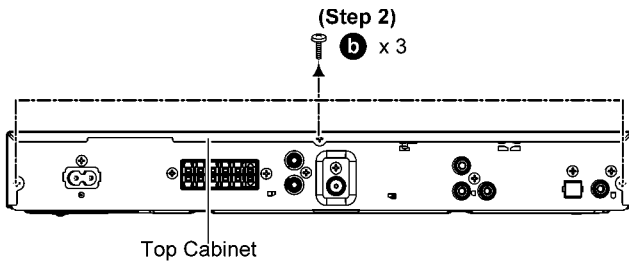

Step 3 Slightly pull both sides of the Top Cabinet as diagram shown.

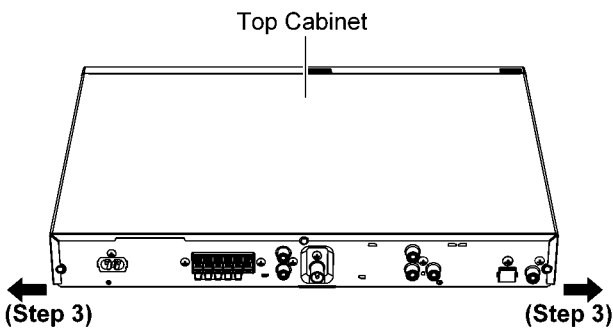

Step 4 Slightly lift both sides of the Top Cabinet in an outward direction about 30°.

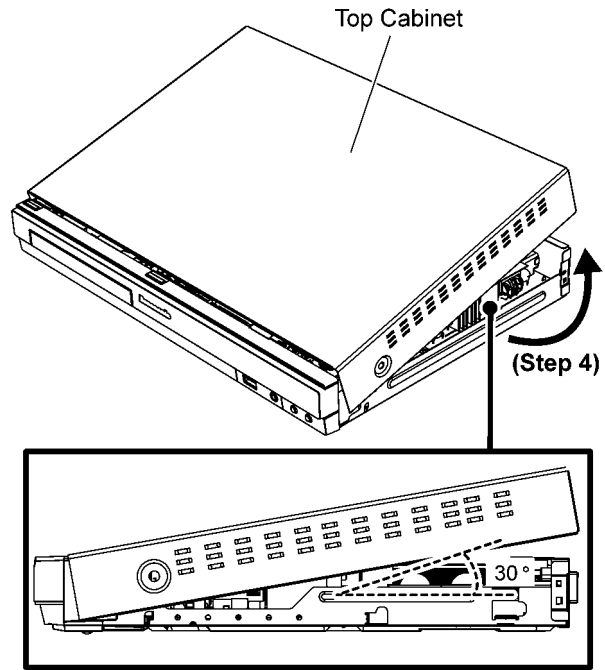

Step 5 Press the catches and remove the Top Cabinet as arrow shown in sequence.

Caution: Avoid touching electrical components when hand is inserted under the Top Cabinet.

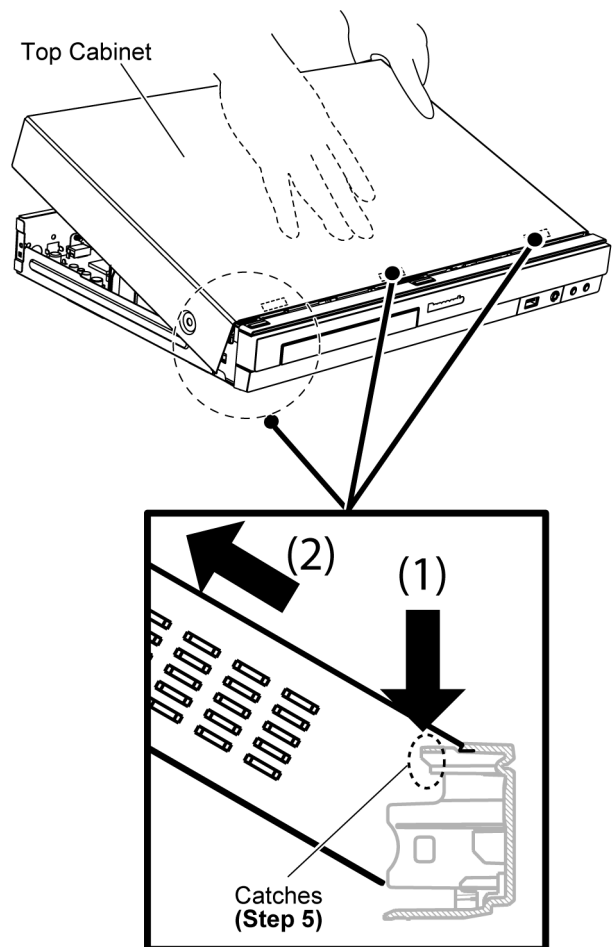

Caution: During assembling, ensure that the Top Cabinet is inserted into the Front Panel Block Assembly.

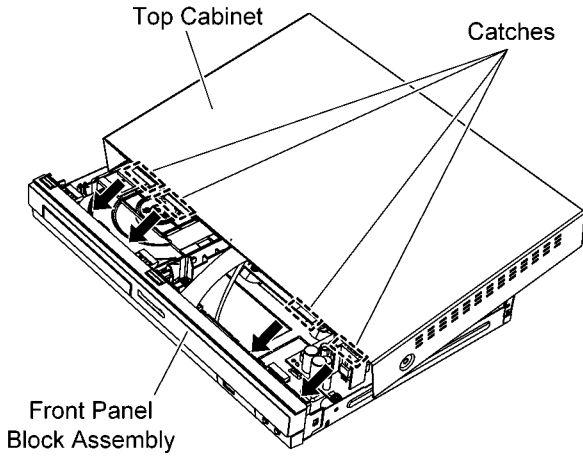

Caution: Replace the Top Cabinet Insulator sheet if broken. Ensure it is pasted properly on the Top Cabinet as diagram shown.

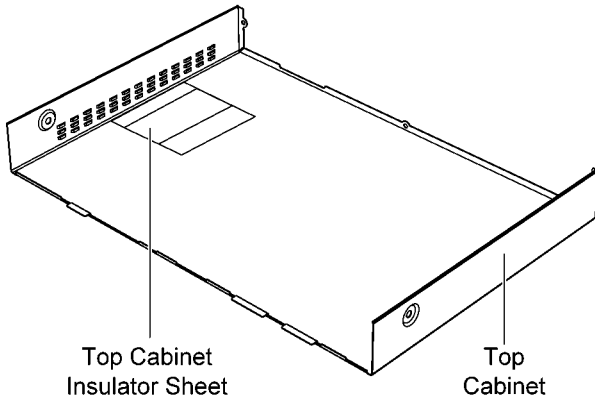

12.5. Replacement of Tray Ornament

Step 1 Use a Paper Clip and insert into the hole on the bottom of the unit.

Step 2 Push the Paper Clip sideways in the direction of the arrow to eject Tray.

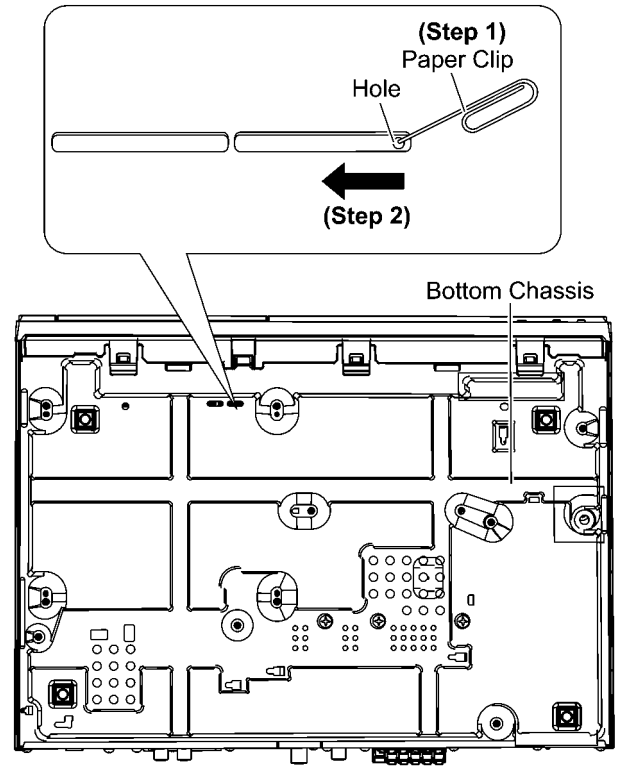

Step 3 Slide the Tray out as direction of arrow.

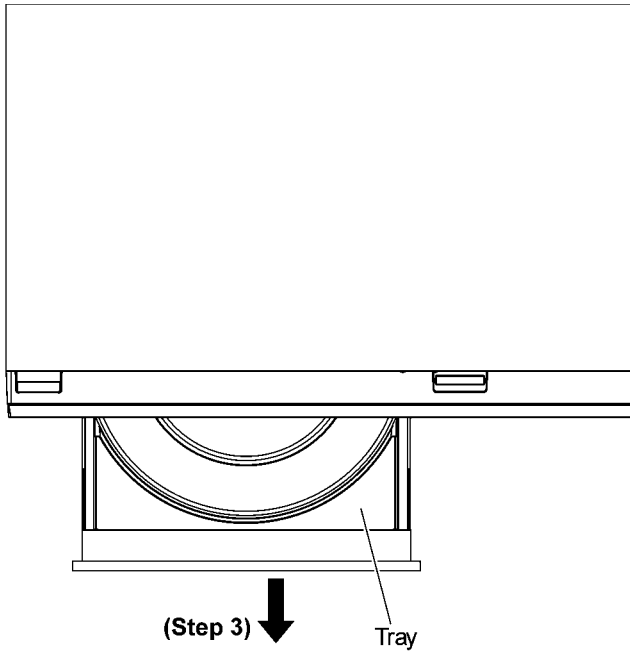

Step 4 Upset the Unit.
Step 5 Release 2 catches.

Caution: During assembling, ensure that the Tray Ornament is inserted and fully caught onto the Tray.

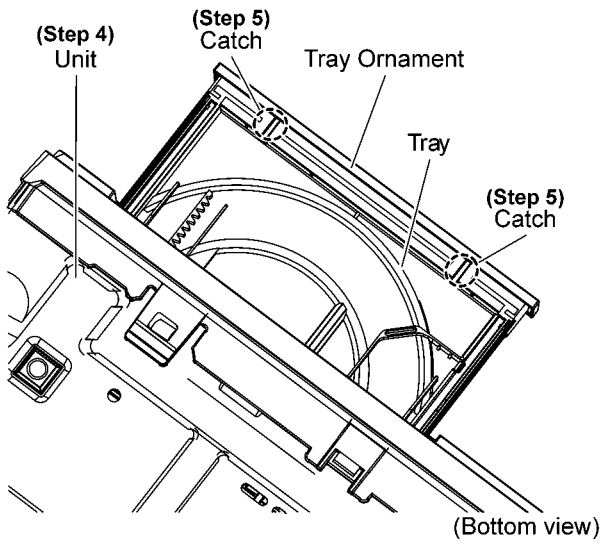

Step 6 Remove the Tray Ornament in the direction of arrow.

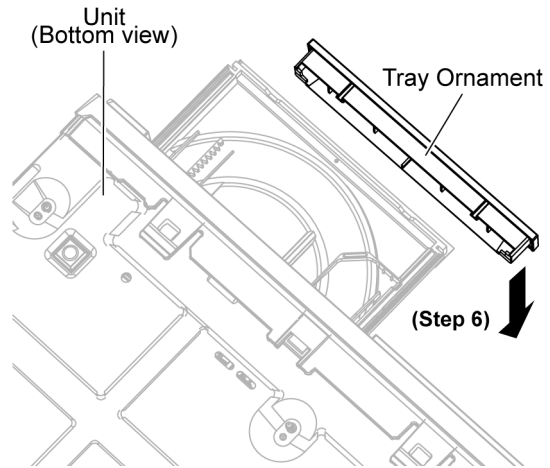

Caution: During assembling, ensure that the Tray Ornament's guide rib is properly inserted onto the Tray.

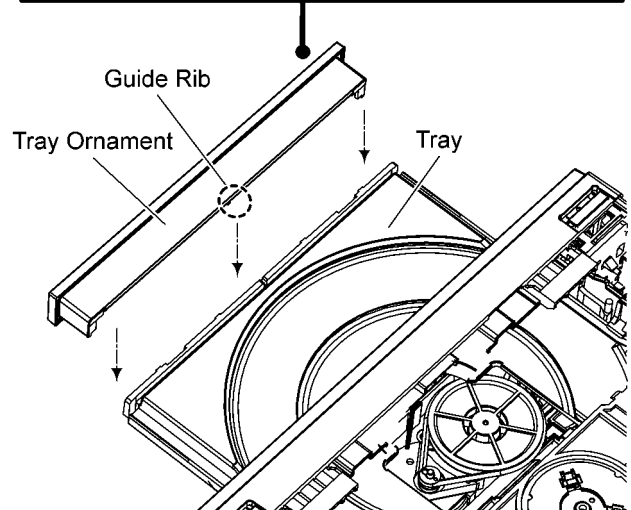
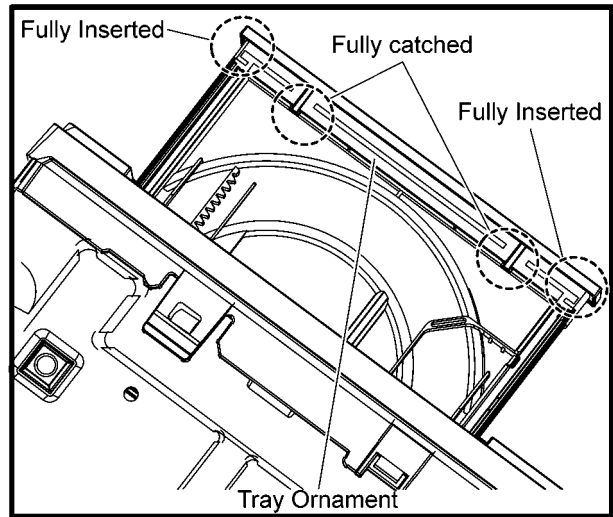

Step 7 Slide the Tray in fully.

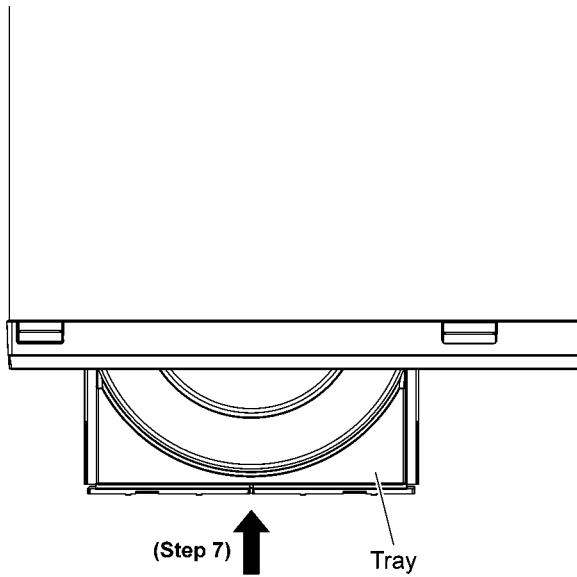

12.6. Disassembly of Front Panel Block Assembly

- Refer to "Disassembly of Top Cabinet".
- Refer to "Replacement of Tray Ornament".

Step 1 Detach 5P Wire at the connector (FP9001) on Backend P.C.B..

Step 2 Detach 17P FFC at the connector (CN203) on Main P.C.B..

Step 3 Lift up the Himelon.

Caution: Replace the Himelon if it is torn.

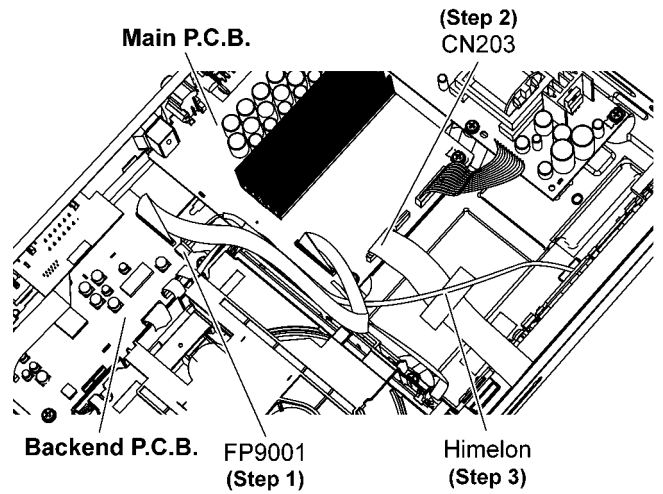

Step 4 Release 2 tabs at each side of the Front Panel Block Assembly in the direction of arrow.

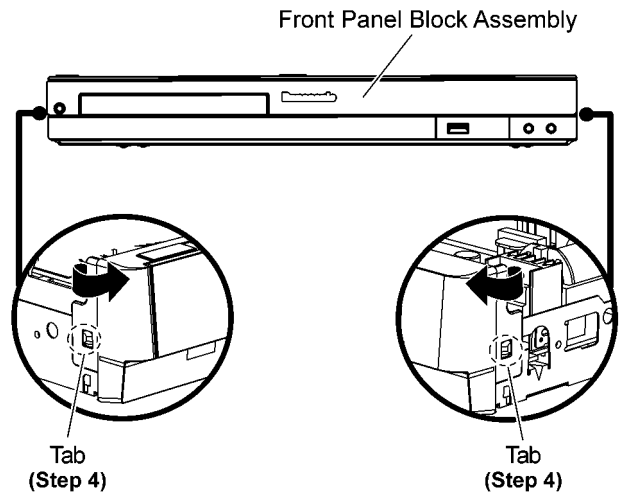

Step 5 Release 3 tabs at the Bottom Chassis.
Caution: Do not exert strong force when releasing the tabs.

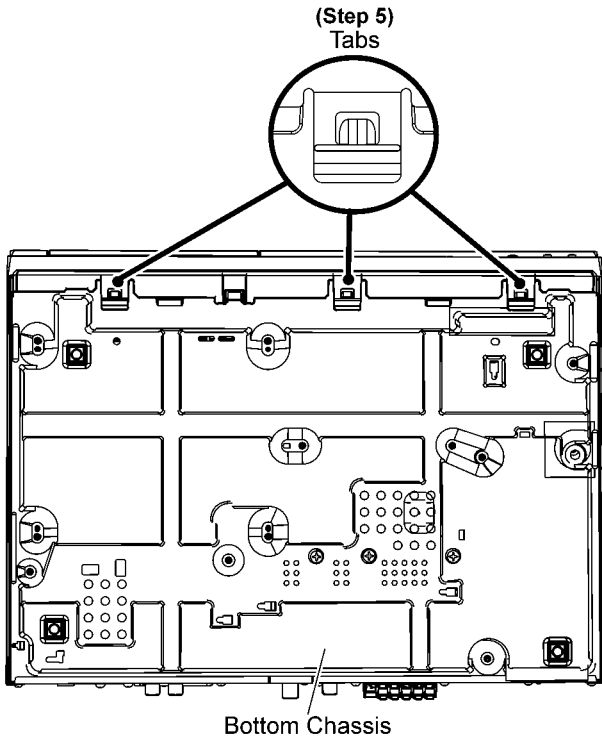

Caution: During assembling, ensure that the Front Panel Block Assembly is inserted properly and fully caught onto the Bottom Chassis.

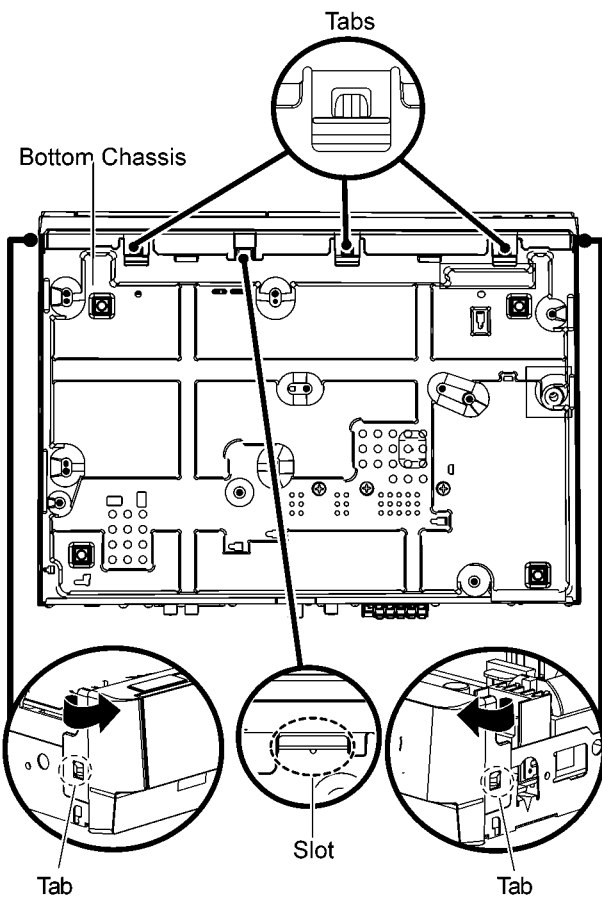

Step 6 Remove the Front Panel Block Assembly.

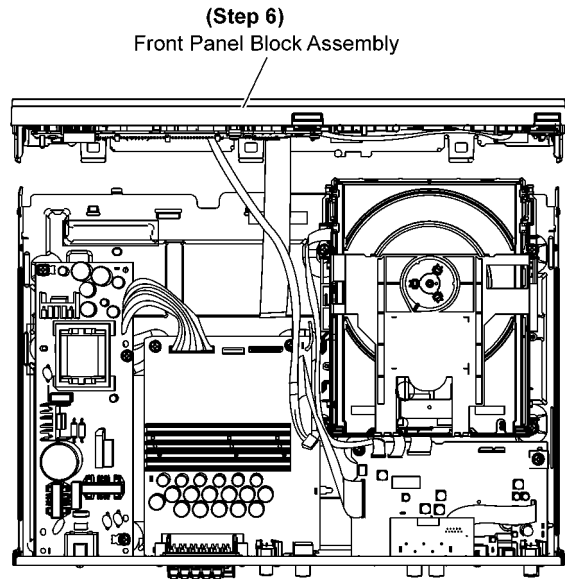

12.7. Disassembly of Panel P.C.B.

- Refer to "Disassembly of Top Cabinet".
- Refer to "Replacement of Tray Ornament".
- Refer to "Disassembly of Front Panel Block Assembly".

Step 1 Remove 4 screws.

Step 2 Remove 1 screw.

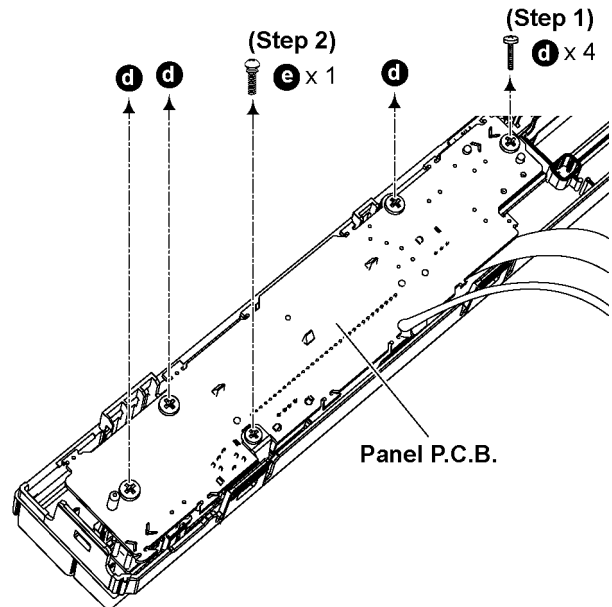

Step 3 Release the 3P Cable from the ribs of Front Panel Block Assembly.

Caution: During assembling, ensure the 3P Cable is inserted properly into the ribs of the Front Panel Block Assembly as diagram shown.

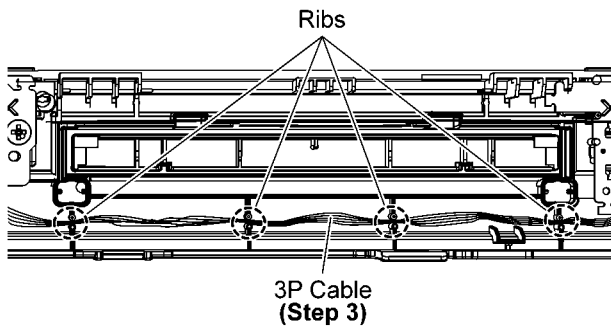

Step 4 Lift up the Panel P.C.B..

Caution: During assembling, ensure that the Panel P.C.B. is located properly and fully seated onto the Front Panel Block Assembly.

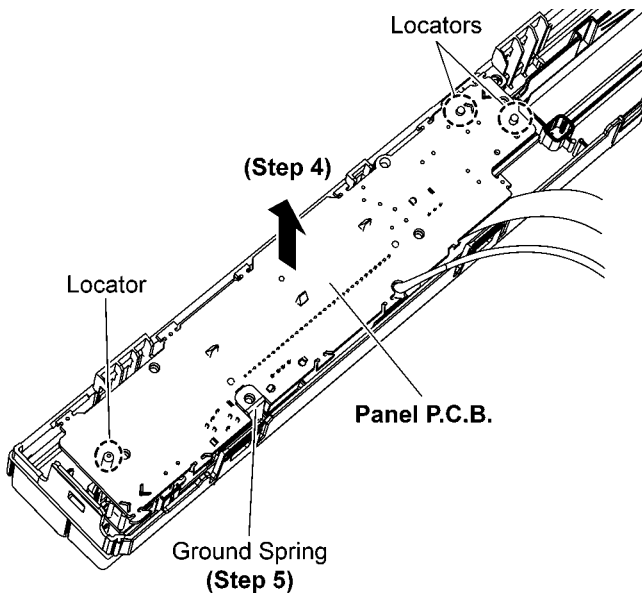

Step 5 Remove the Ground Spring.

Caution: Keep the Ground Spring in safe place, place it back during assembling.

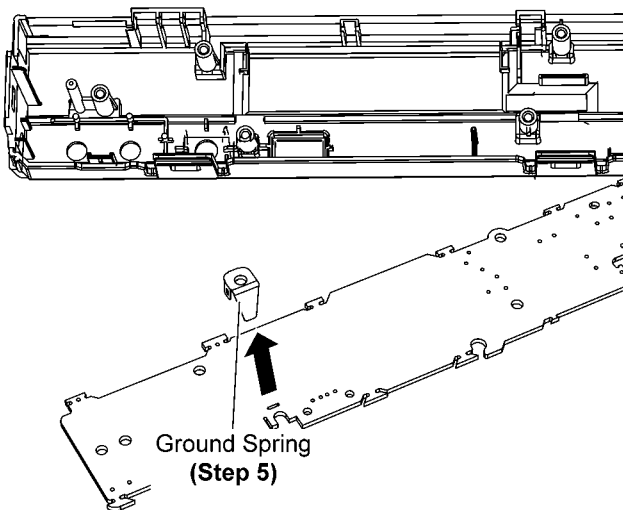

Step 6 Desolder the 3P Cable at the cable holder (H902) on Panel P.C.B..

Step 7 Remove the Panel P.C.B..

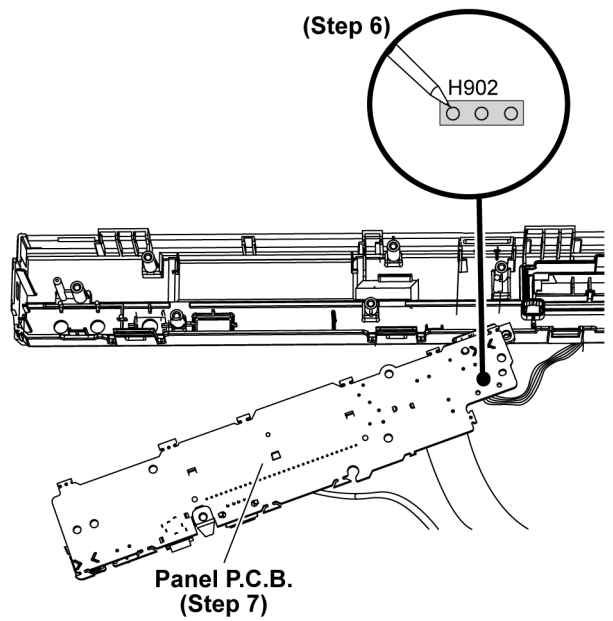

Caution: During assembling, ensure that both the 5P wire & 17P FFC are dressed as diagram shown.

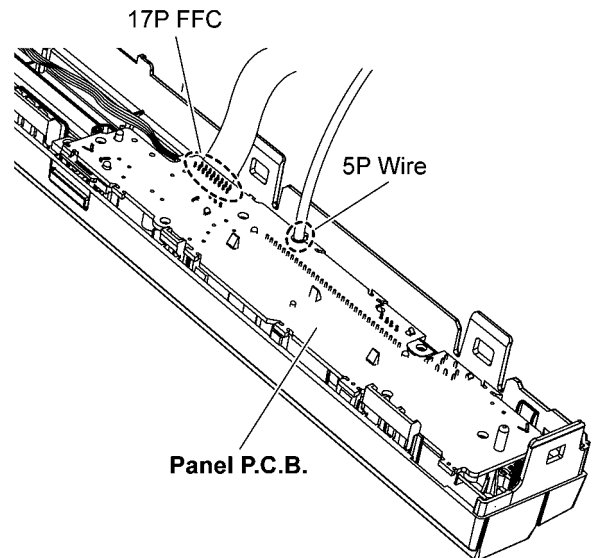

12.8. Disassembly of Power Button P.C.B.

- Refer to “Disassembly of Top Cabinet”.
- Refer to “Replacement of Tray Ornament”.
- Refer to “Disassembly of Front Panel Block Assembly”.

Step 1 Remove 1 screw.

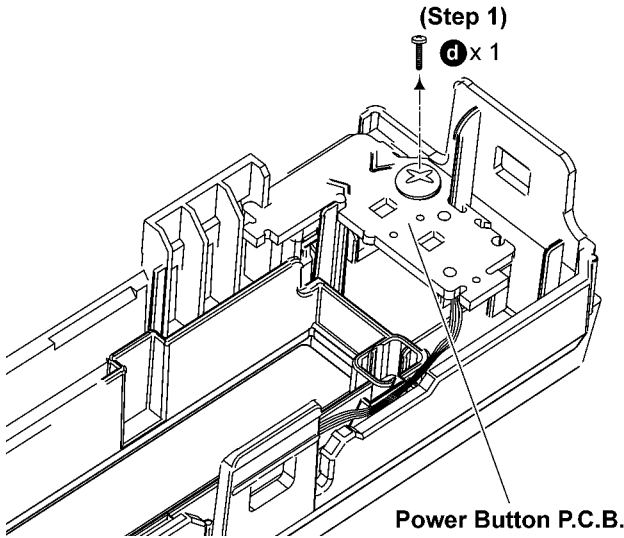

Step 2 Lift up the Power Button P.C.B. as direction of arrow.

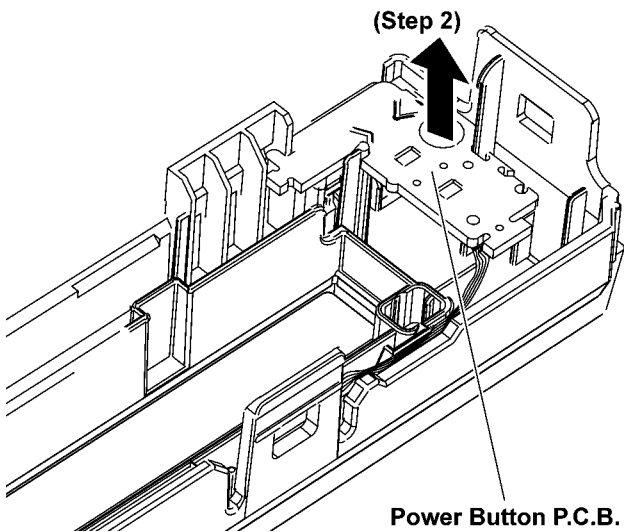

Caution: During assembling, ensure that the Power Button P.C.B. is located properly and fully seated onto the Front Panel Block Assembly.

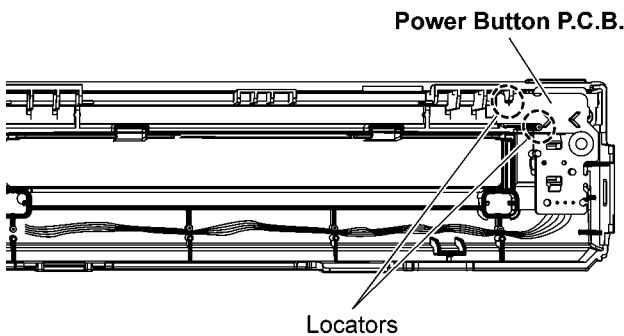

Step 3 Release the 3P Cable from the ribs of the Front Panel Block Assembly.

Caution: During assembling, ensure that 3P Cable is properly dressed into the ribs of the Front Panel Block Assembly as diagram shown.

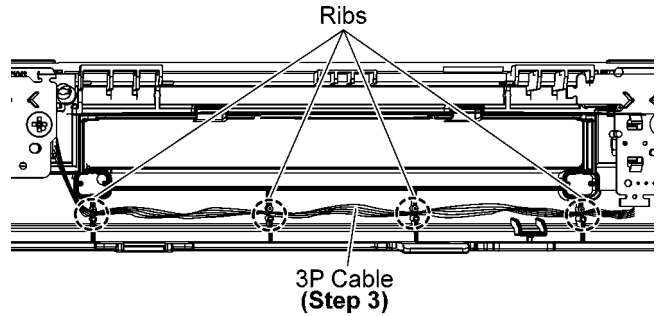

Step 4 Desolder the 3P Cable at the cable holder (H901) on Power Button P.C.B..

Step 5 Remove the Power Button P.C.B..

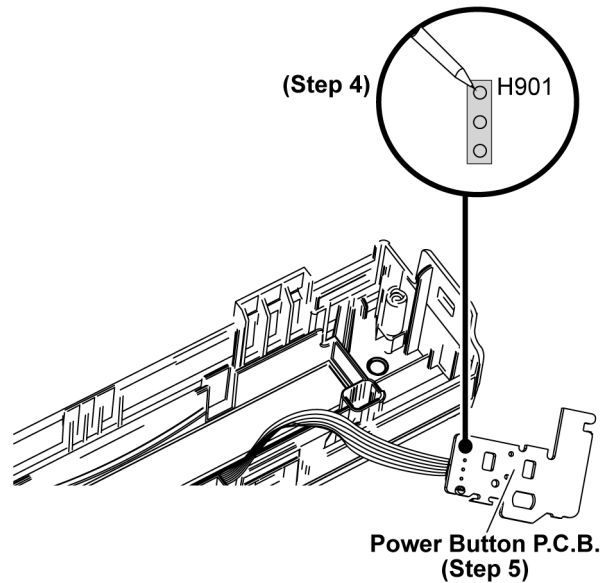

12.9. Disassembly of Rear Panel

• Refer to “Disassembly of Top Cabinet”

Step 1 Remove 8 screws.

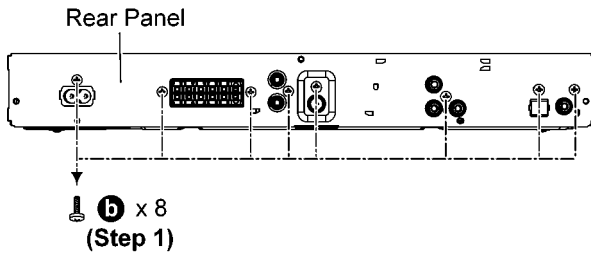

Step 2 Release tabs of each side of the Rear Panel in the direction of arrow.

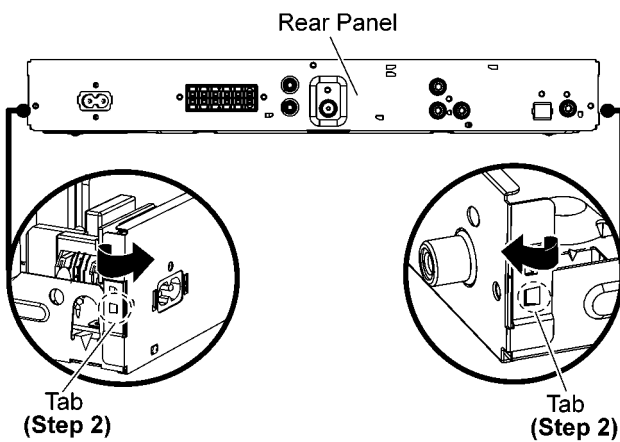

Step 3 Remove the Rear Panel.

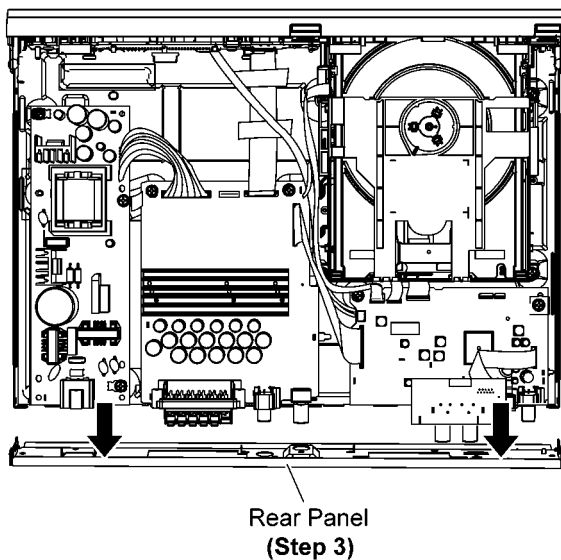

12.10. Disassembly of SMPS P.C.B.

• Refer to “Disassembly of Top Cabinet”

Step 1 Remove 1 screw.

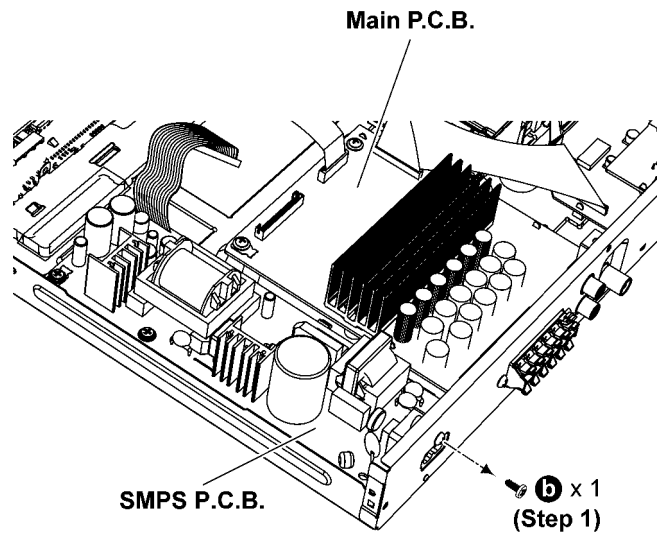

Step 2 Detach 12P cable at the connector (CN100) on Main P.C.B..

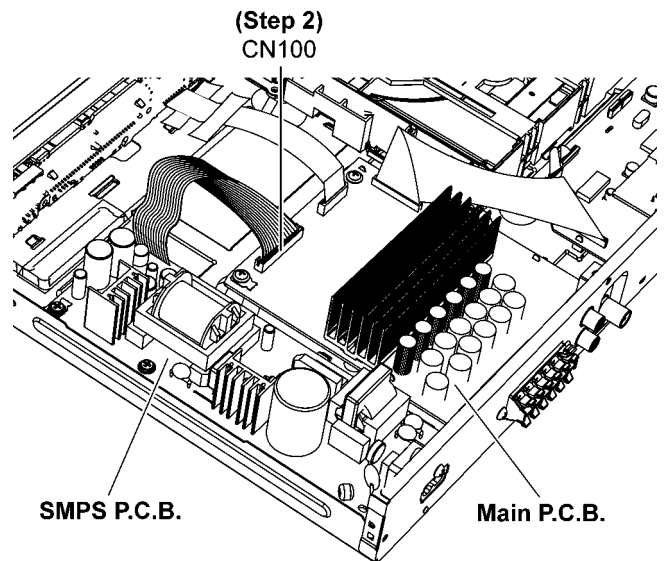

Step 3 Remove 4 screws.

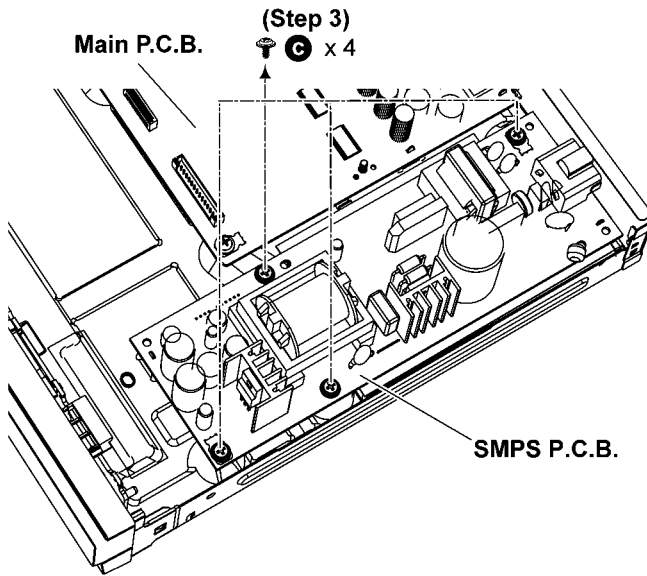

Caution: Replace the Bottom PC Sheet if broken. Ensure that it is pasted on the Bottom Chassis properly.

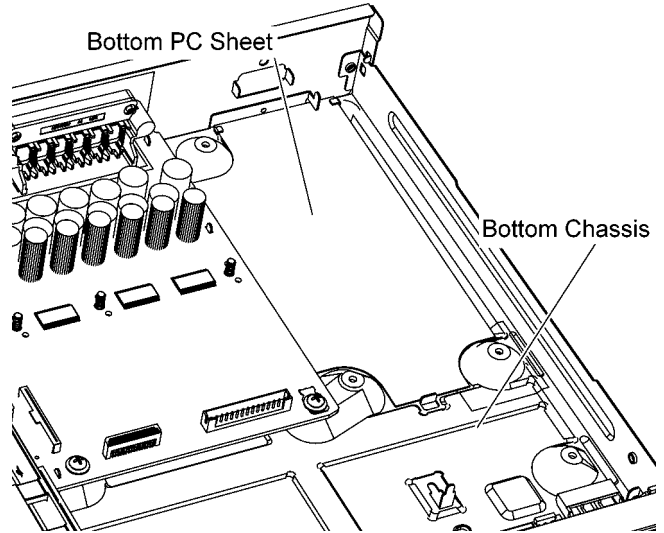

Step 4 Lift up to remove the SMPS P.C.B..

Caution: Handle the SMPS P.C.B. with care. Avoid touching the heatsink due to its prolong use.

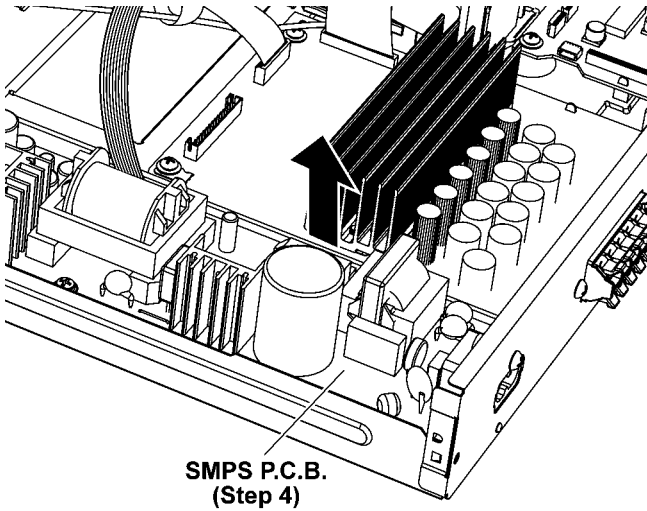

12.11. Replacement of Current Limiting Switch (Q5701)

- Refer to "Disassembly of Top Cabinet".
- Refer to "Disassembly of SMPS P.C.B.".

12.11.1. Disassembly of Current Limiting Switch (Q5701)

Step 1 Desolder pins of the Current Limiting Switch (Q5701) on the solder side of SMPS P.C.B..

Caution: During assembling, ensure that the SMPS P.C.B. is located properly and fully seated onto the Bottom Chassis.

Solder Side of SMPS P.C.B.

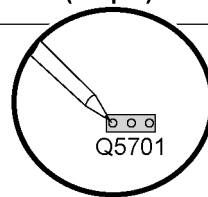
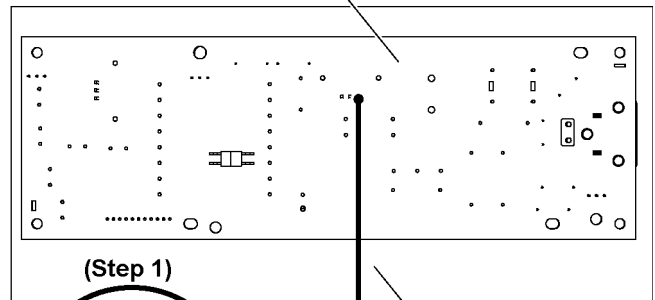

Insulated Material

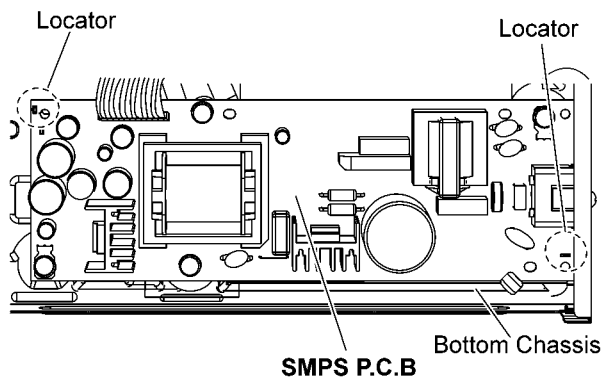

Step 2 Remove 1 screw from the Current Limiting Switch (Q5701).

Step 3 Remove the Current Limiting Switch (Q5701) from the Heatsink Ext A.

Caution: Avoid touching Heatsink Ext A due to its high temperature after prolonged use. Touching it may lead to injuries.

Note: Refer to the diagrams of SMPS P.C.B. (Item 18.4) for location of the part.

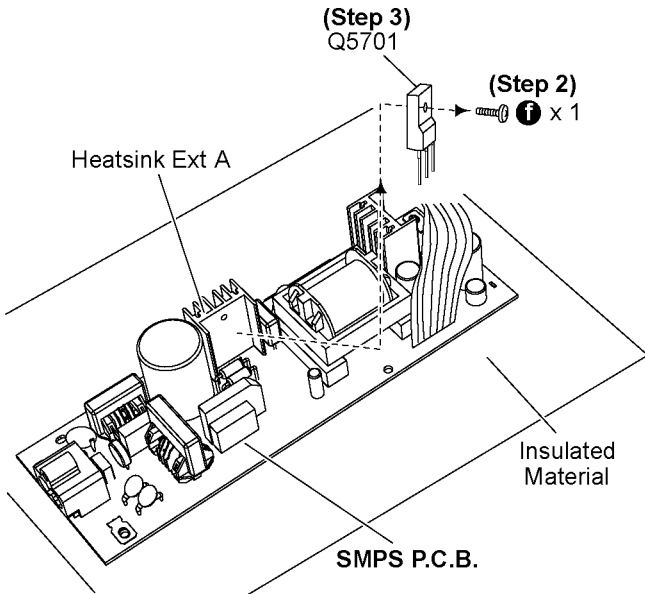

Step 4 Solder pins of the Current Limiting Switch (Q5701) on the solder side of the SMPS P.C.B..

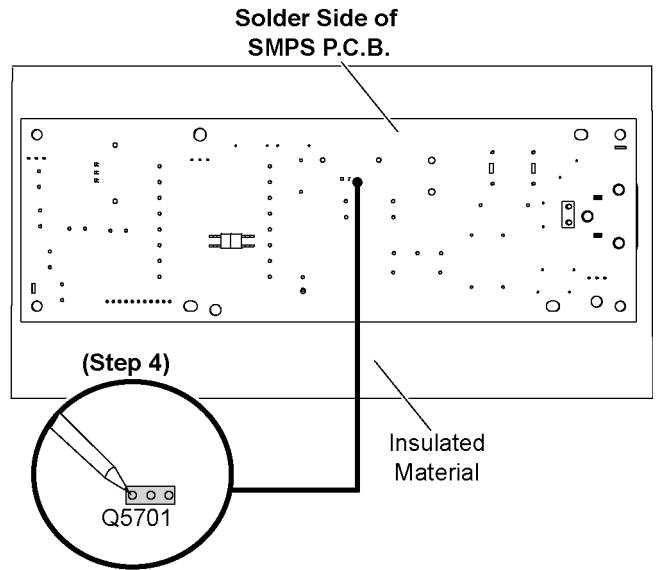

12.11.2. Assembly of Current Limiting Switch (Q5701)

Step 1 Apply grease to the Heatsink Ext A.

Step 2 Fix the Current Limiting Switch (Q5701) to the SMPS P.C.B..

Caution: Ensure that the Current Limiting Switch (Q5701) is inserted properly onto SMPS P.C.B. before soldering.

Step 3 Fix and screw the Current Limiting Switch (Q5701) to the Heatsink Ext A.

Caution: Ensure that the Current Limiting Switch (Q5701) is tightly screwed to the Heatsink Ext A.

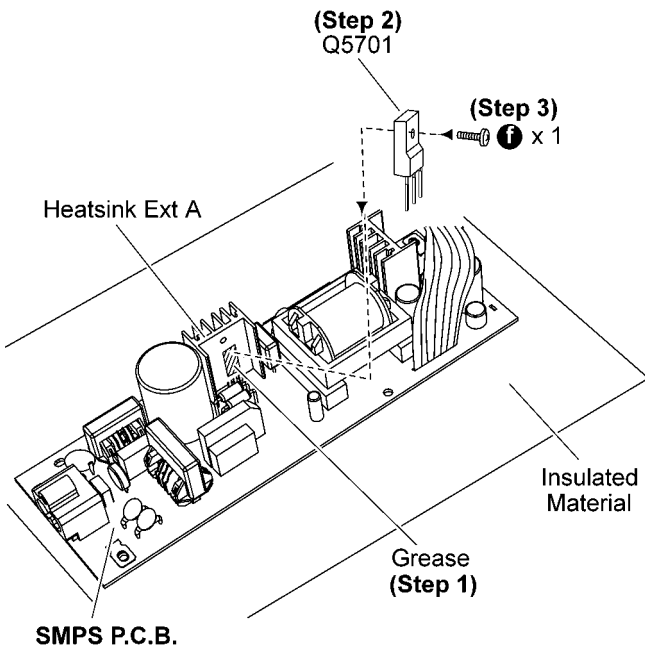

12.12. Replacement of Diode (D5706)

- Refer to “Disassembly of Top Cabinet.”
- Refer to “Disassembly of SMPS P.C.B.”.

12.12.1. Disassembly of Diode (D5706)

Step 1 Desolder pins of the Diode (D5706) on the solder side of the SMPS P.C.B..

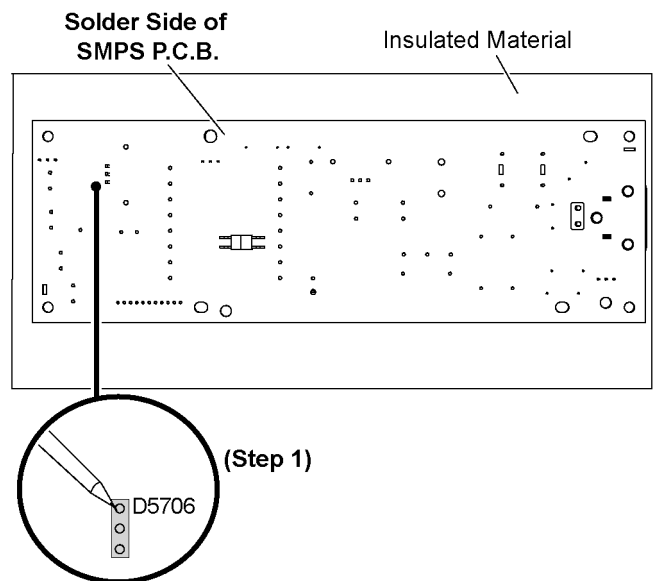

Step 2 Remove 1 screw from the Diode (D5706).

Step 3 Remove the Diode (D5706) from the Heatsink Ext B.

Caution: Avoid touching Heatsink Ext B due to its high temperature after prolonged use. Touching it may lead to injuries.

Note: Refer to the diagrams of SMPS P.C.B. (Item 18.4) for location of the part.

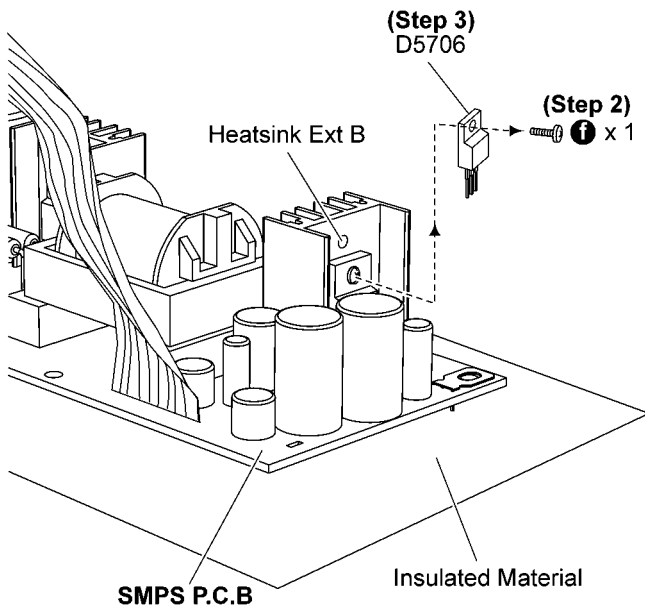

Step 4 Solder pins of the Diode (D5706) on the solder side of the SMPS P.C.B..

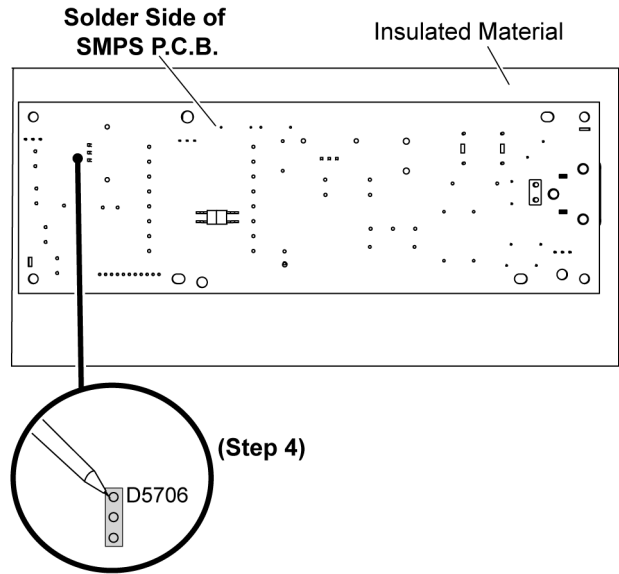

12.13. Disassembly of Main P.C.B.

• Refer to “Disassembly of Top Cabinet”.

Step 1 Remove 8 screws.

Step 2 Release 2 tabs at each side of Rear Panel in the direction of arrow.

12.12.2. Assembly of Diode (D5706)

Step 1 Apply grease to the Heatsink Ext B.

Step 2 Fix the Diode (D5706) to the SMPS P.C.B..

Caution: Ensure that the Diode (D5706) is seated properly onto the SMPS P.C.B. before soldering.

Step 3 Fix and screw the Diode (D5706) to the Heatsink Ext B.

Caution: Ensure that the Diode (D5706) is tightly screwed to the Heatsink Ext B.

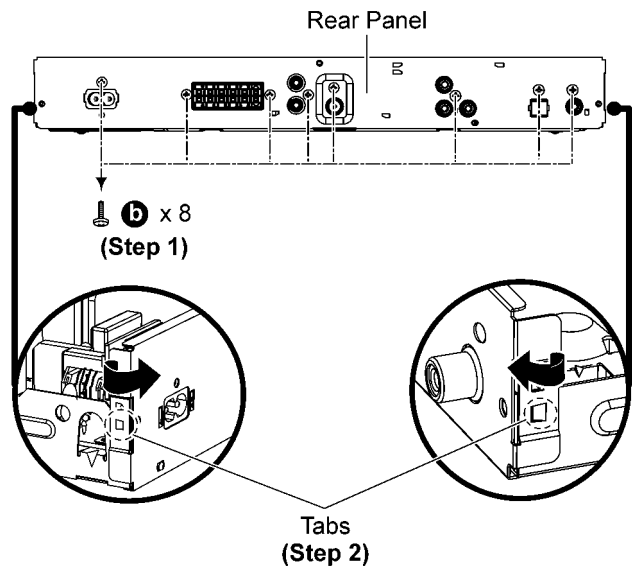
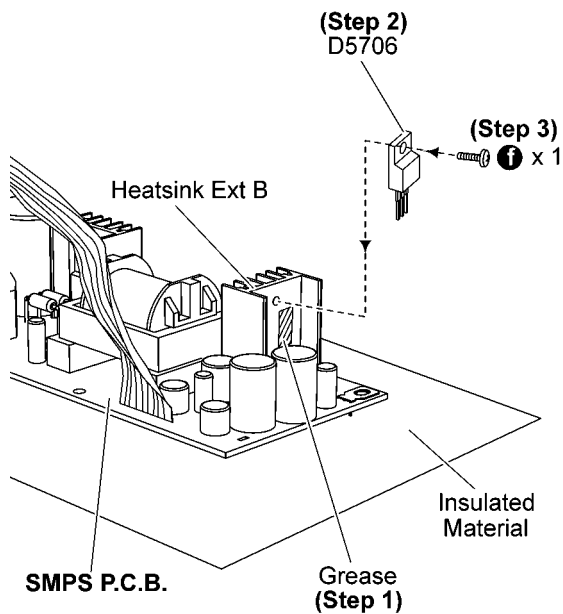

Step 3 Detach 12P Cable at the connector (CN100) on Main P.C.B..

Step 4 Detach 17P FFC at the connector (CN203) on Main P.C.B..

Step 5 Detach 50P FFC at the connector (CN201) on Main P.C.B..

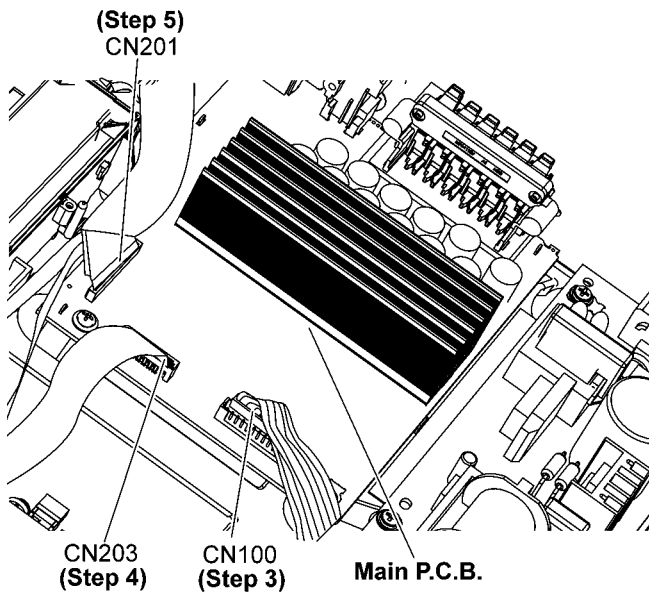

Step 6 Remove 2 screws.

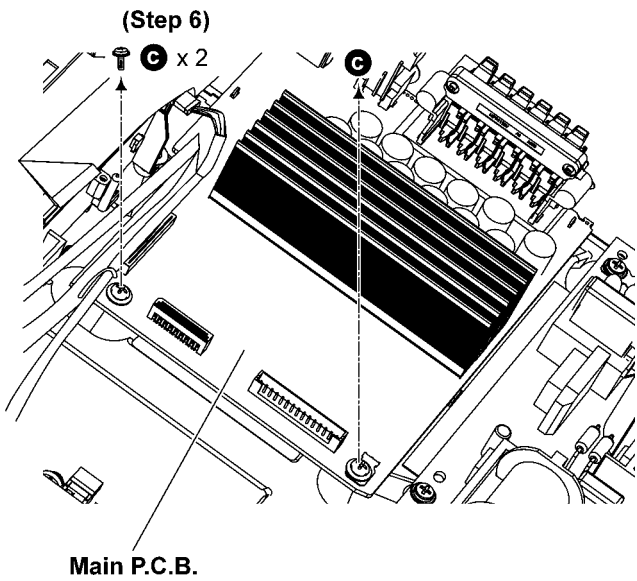

Step 7 Slightly lift up to remove the Main P.C.B..

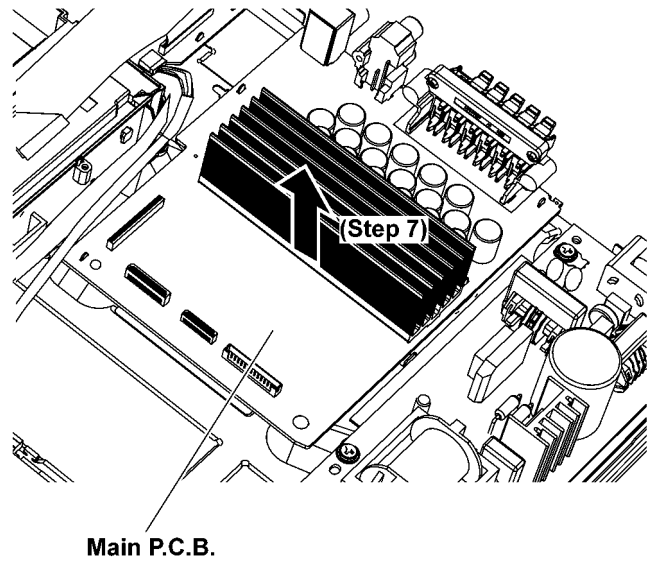

Caution: During assembling, ensure that the Main P.C.B. is located properly and fully seated onto the Bottom Chassis.

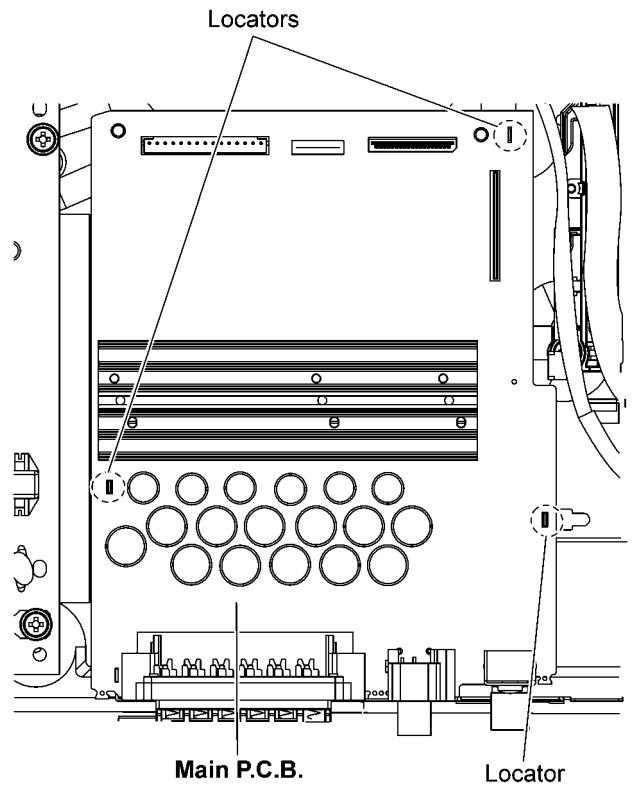

12.14. Replacement of Digital Amplifier IC (IC403/IC404/IC405)

- Refer to "Disassembly of Top Cabinet".
- Refer to "Disassembly of Main P.C.B.".

12.14.1. Disassembly of Digital Amplifier IC (IC403/IC404/IC405)

Caution: Handle the Main P.C.B. with caution due to its high temperature after prolonged use.

Step 1 Place Main P.C.B. on an insulated material.

Step 2 Remove 3 screws.

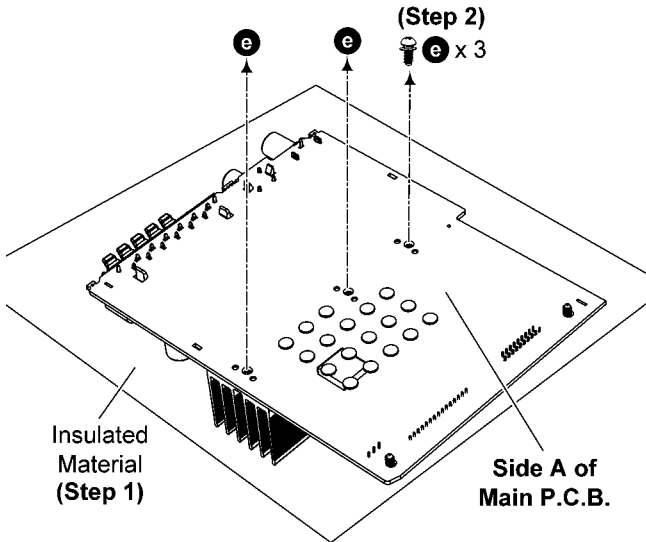

Step 3 Lift up Main P.C.B. as arrow shown.

Caution: Keep the Heatsink Spacers in safe place. Avoid denting it, place it back during assembling.

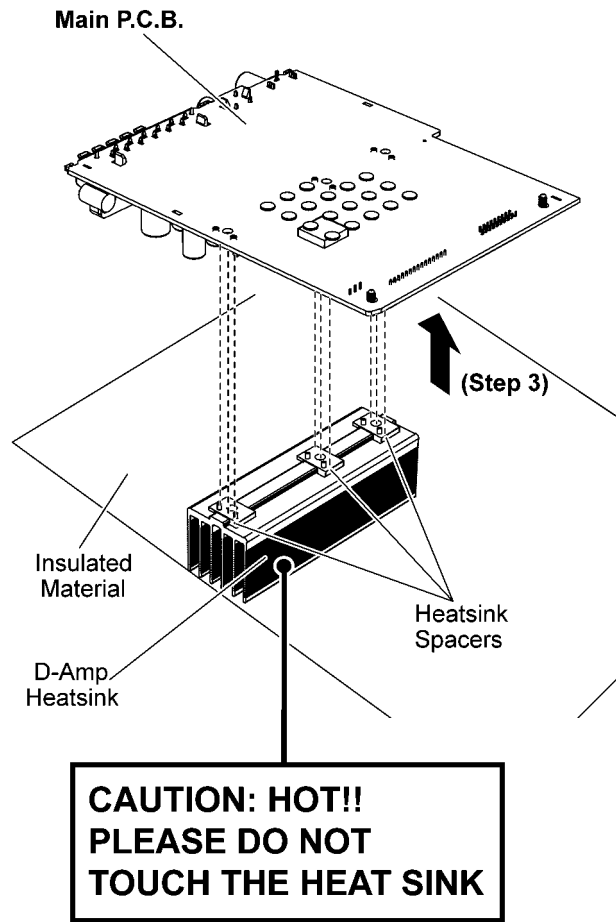

Step 4 Desolder the pins of Digital Amplifier IC (IC403).

Step 5 Remove Digital Amplifier IC (IC403).

Note 1: For disassembling of Digital Amplifier IC (IC404) & (IC405), repeat the (Step 1) to (Step 5) of 12.14.1.

Note 2: Refer to diagram of Main P.C.B. (item 18.2) for location of part.

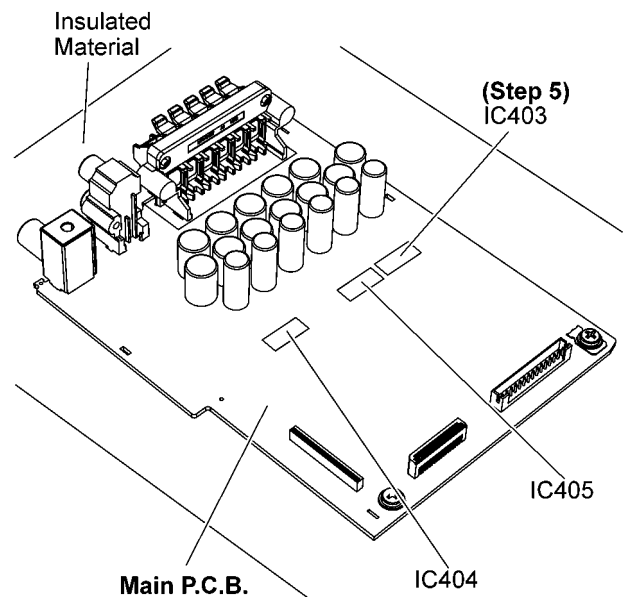

12.14.2. Assembly of Digital Amplifier IC (IC403/IC404/IC405)

Step 1 Fix the Digital Amplifier IC (IC403) onto the Main P.C.B..

Step 2 Solder pins of Digital Amplifier IC (IC403).

Caution: Ensure that the pins of Digital Amplifier IC (IC403) is positioned correctly on Main P.C.B. before soldering.

Step 3 Apply grease on the top side of the Digital Amplifier IC (IC403).

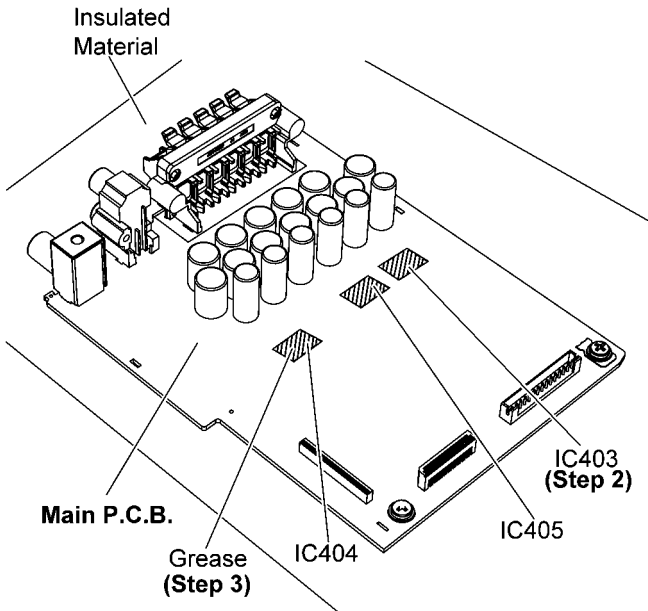

Step 4 Fix Heatsink spacers onto D-Amp Heatsink.

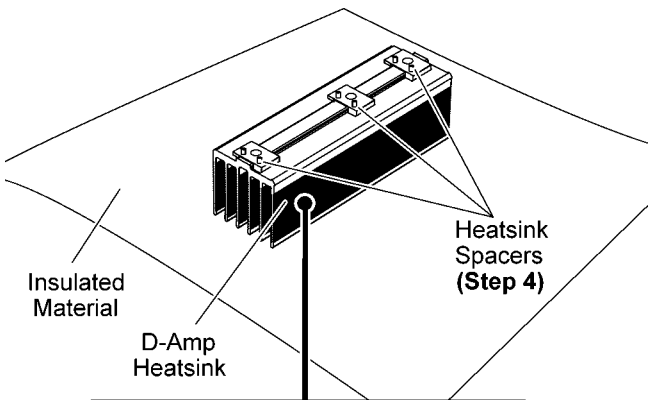

**CAUTION: HOT!!
PLEASE DO NOT
TOUCH THE HEAT SINK**

Step 5 Upset the Main P.C.B..

Step 6 Fix 3 screws.

Note: For assembling of Digital Amplifier IC (IC404) & (IC405), repeat the (Step 1) to (Step 6) of 12.14.2.

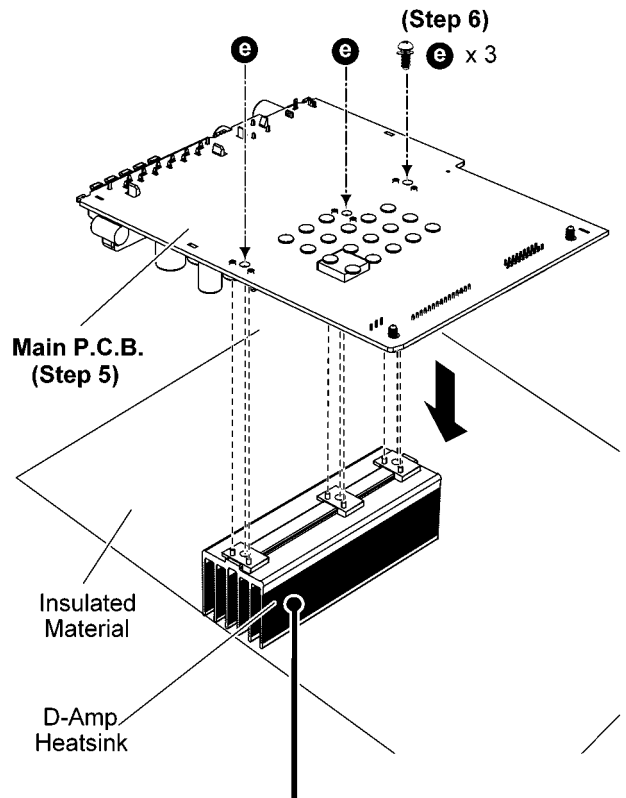

**CAUTION: HOT!!
PLEASE DO NOT
TOUCH THE HEAT SINK**

12.15. Disassembly of Backend P.C.B.

- Refer to "Disassembly of Top Cabinet".
- Refer to "Disassembly of Component Video P.C.B.".

Step 1 Remove 8 screws.

Step 2 Release 2 tabs at each side of the Rear Panel in the direction of arrow.

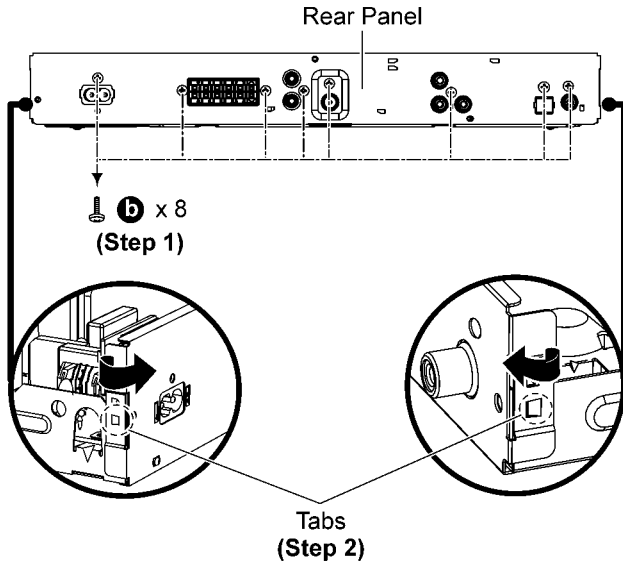

Step 3 Detach 24P FFC at the connector (FP8531) on Backend P.C.B..

Step 4 Detach 6P FFC at the connector (FP8251) on Backend P.C.B..

Step 5 Detach 5P FFC at the connector (FP8252) on Backend P.C.B..

Step 6 Detach 5P Cable at the connector (FP9001) on Backend P.C.B..

Step 7 Detach 50P FFC at the connector (FP8101) on Backend P.C.B..

Step 8 Detach 11P FFC at the connector (FP8301) on Backend P.C.B..

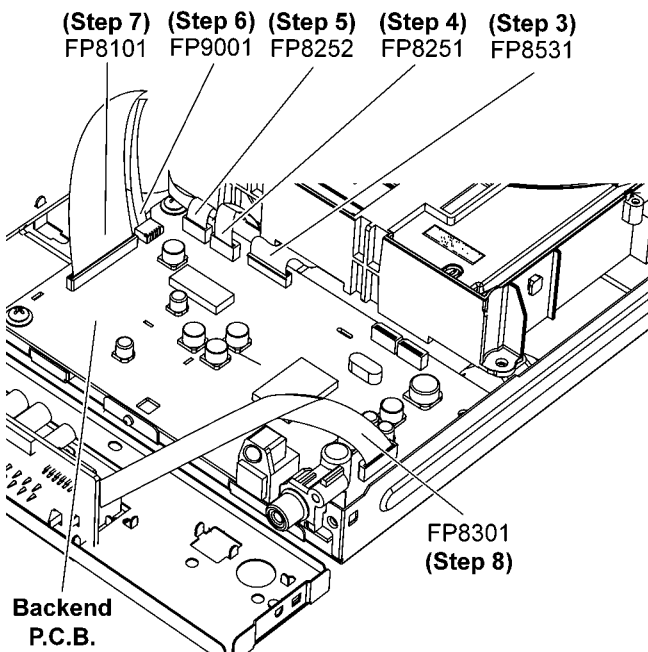

Step 9 Remove 2 screws.

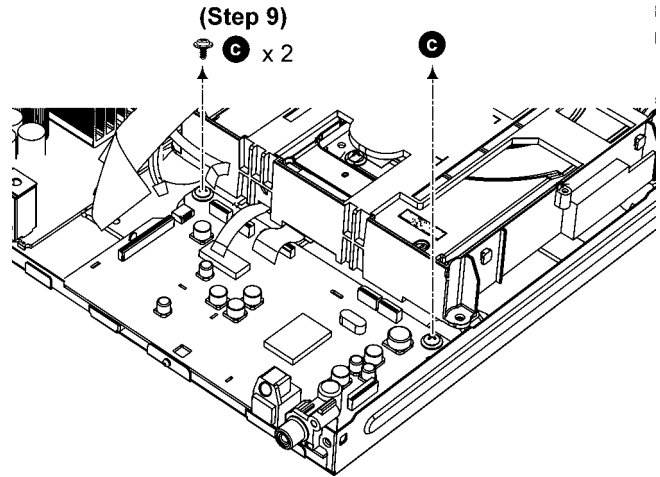

Step 10 Lift up the Backend P.C.B..

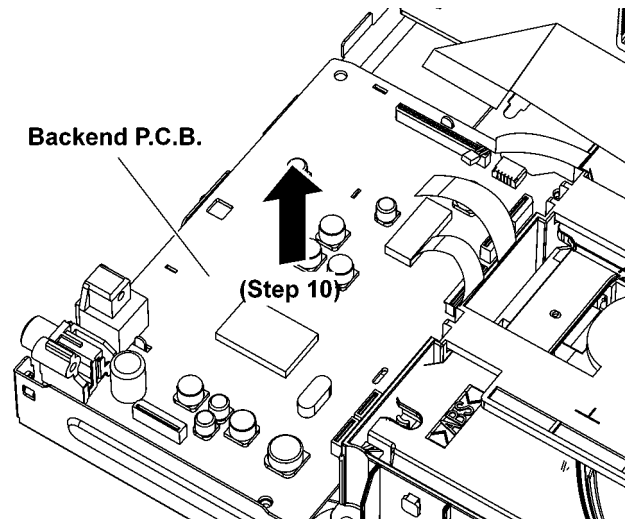

Caution: During assembling, ensure that the Backend P.C.B. is properly located & fully seated onto the Bottom Chassis.

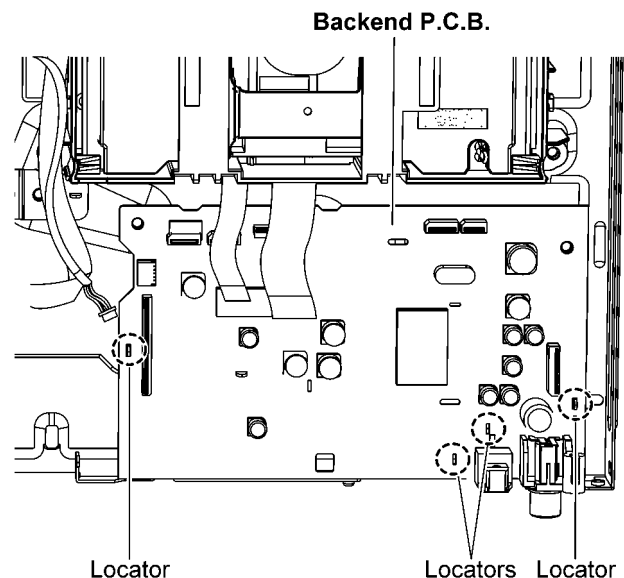

12.16. Disassembly of Component Video P.C.B.

• Refer to “Disassembly of Top Cabinet”.

Step 1 Remove 1 screw.

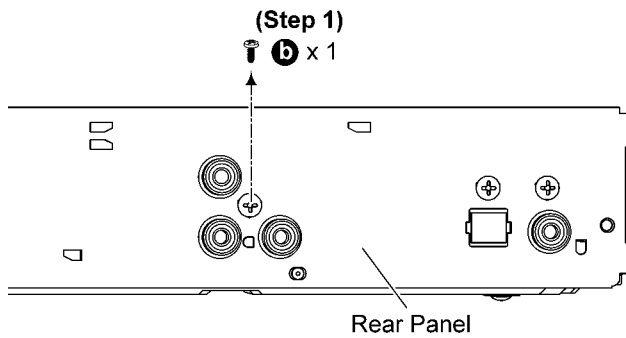

Step 2 Lift up the Component Video P.C.B..

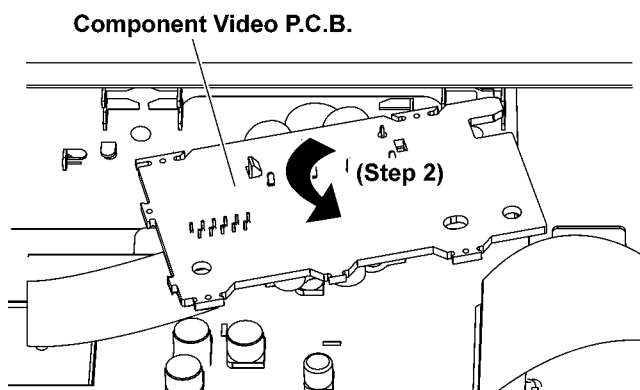

Step 3 Detach 11P FFC at the connector (CN400) on Component Video P.C.B..

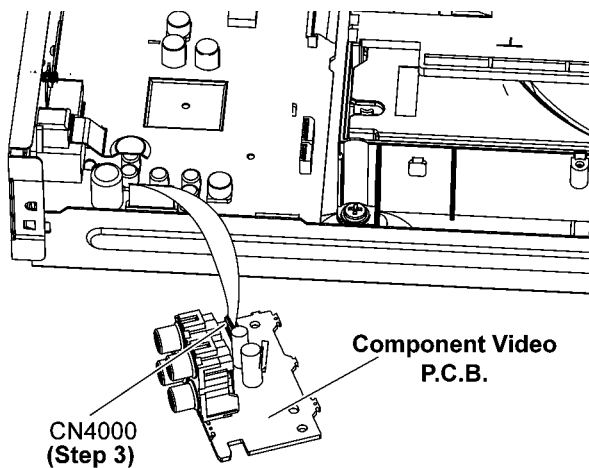

Caution: During assembling, ensure that the Component Video P.C.B. is inserted properly and fully caught onto the rear panel.

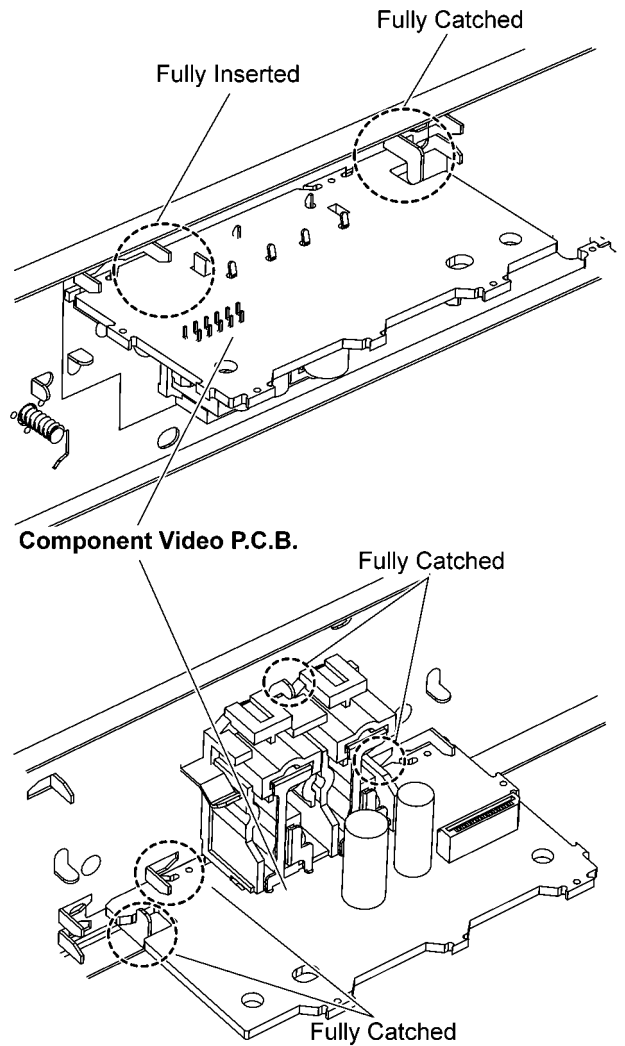

12.17. Disassembly of DVD Mechanism Unit (BRS1D)

- Refer to “Disassembly of Top Cabinet”
- Refer to “Replacement of Tray Ornament”

Step 1 Detach 24P FFC at the connector (FP8531) on Backend P.C.B..

Step 2 Detach 6P FFC at the connector (FP8251) on Backend P.C.B..

Step 3 Detach 5P FFC at the connector (FP8252) on Backend P.C.B..

Caution: During assembling, dress the 5P FFC between Rib A and Rib B as shown.

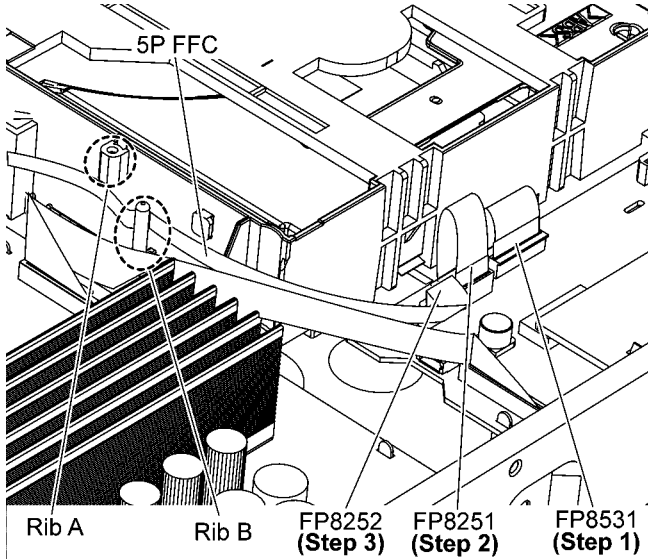

Step 4 Remove 4 screws.

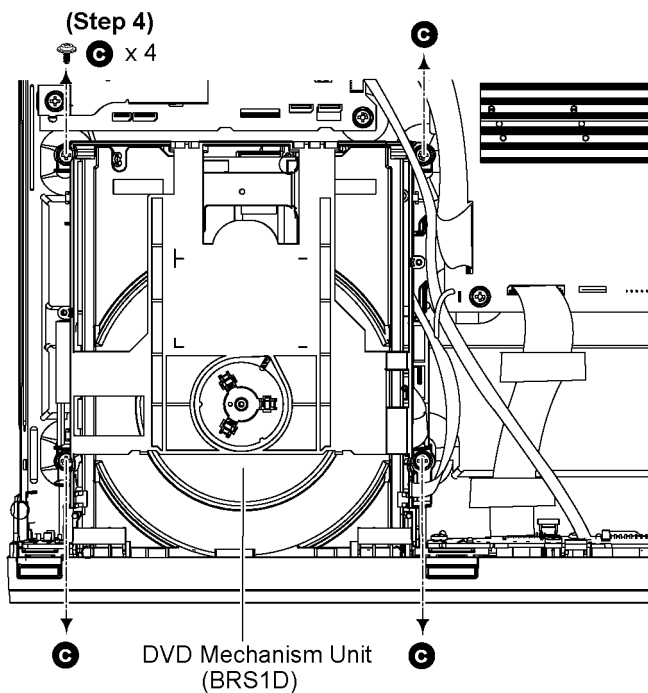

Step 5 Slightly lift up and remove the DVD Mechanism Unit (BRS1D) in the direction of arrow.

Caution: During assembling, ensure that the DVD Mechanism Unit (BRS1D) is inserted properly and fully seated on the Bottom Chassis before screwing.

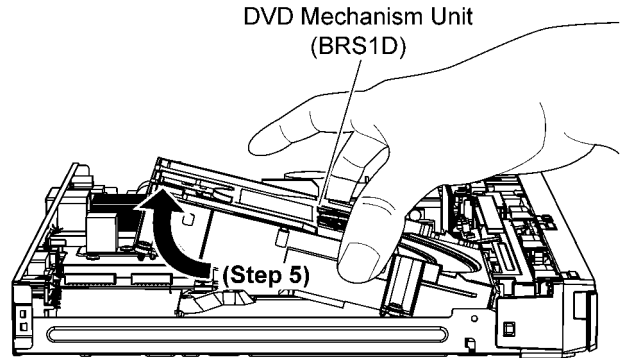

Step 6 Attach a short pin to the 24P FFC of the DVD Mechanism Unit (BRS1D).

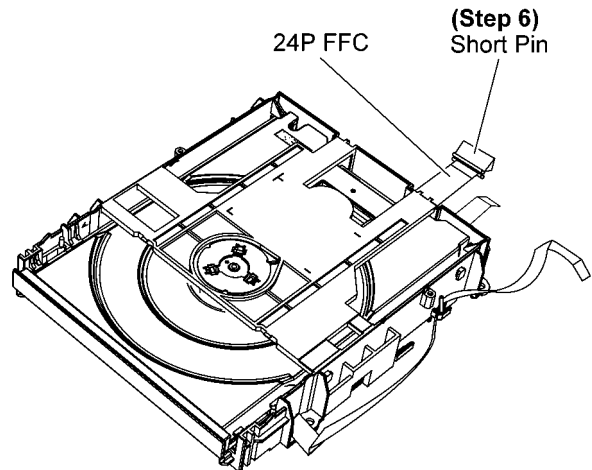

12.18. Replacement of Traverse unit

- Refer to “Disassembly of DVD Mechanism Unit (BRS1D)”.

Caution: Refer to 2.4 “Handling Precaution for Traverse Unit” to prevent static damage to the Optical Pickup unit.

Note:

1. When the optical pickup unit is defective, the overall traverse unit needs replacement.
2. Please note that appropriate actions need to be taken to prevent static damage.

12.18.1. Disassembly of Traverse unit

Step 1 : Use a pin to slide the Traverse Slide Plate until it come to a stop.

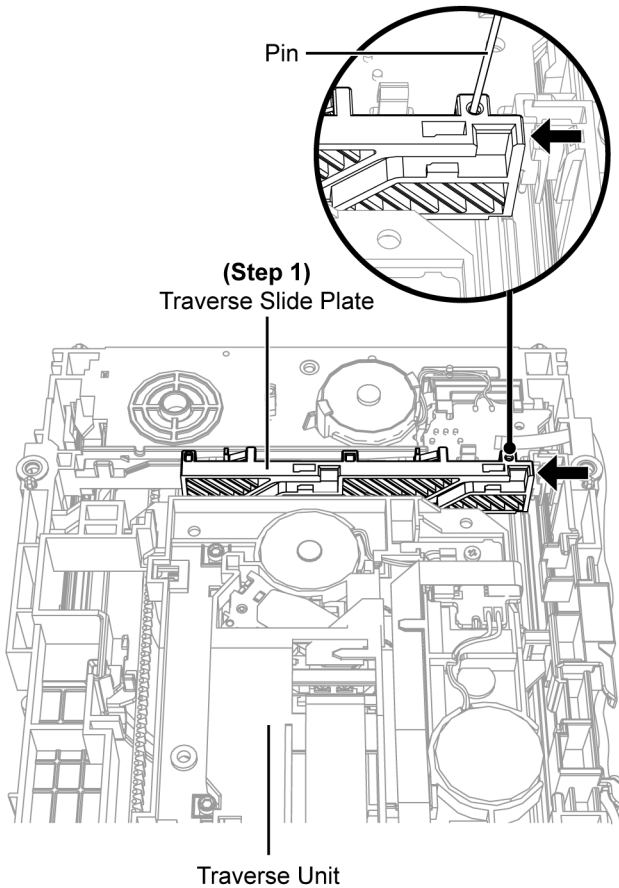

Step 2 : Slide the tray out fully.

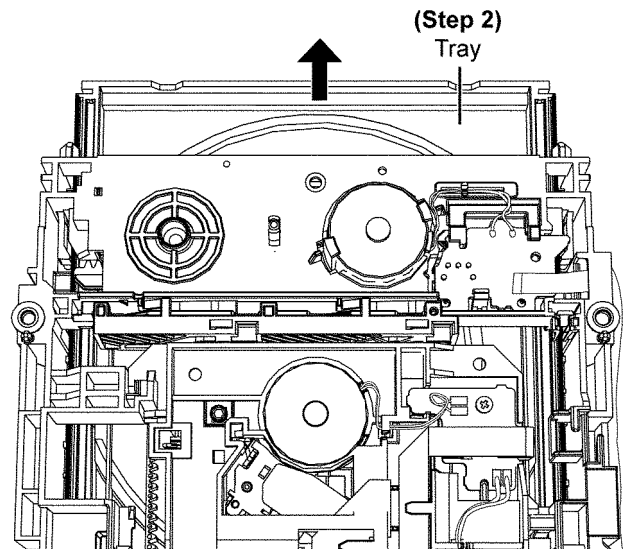

Step 3 : Release the catches & remove the tray.

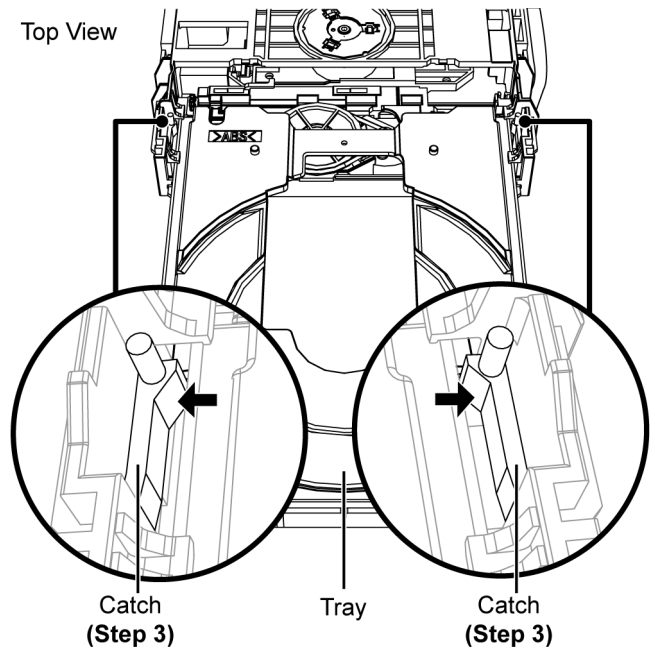

Step 4 : Release the guide as shown & slide the Traverse Slide Plate to the end.

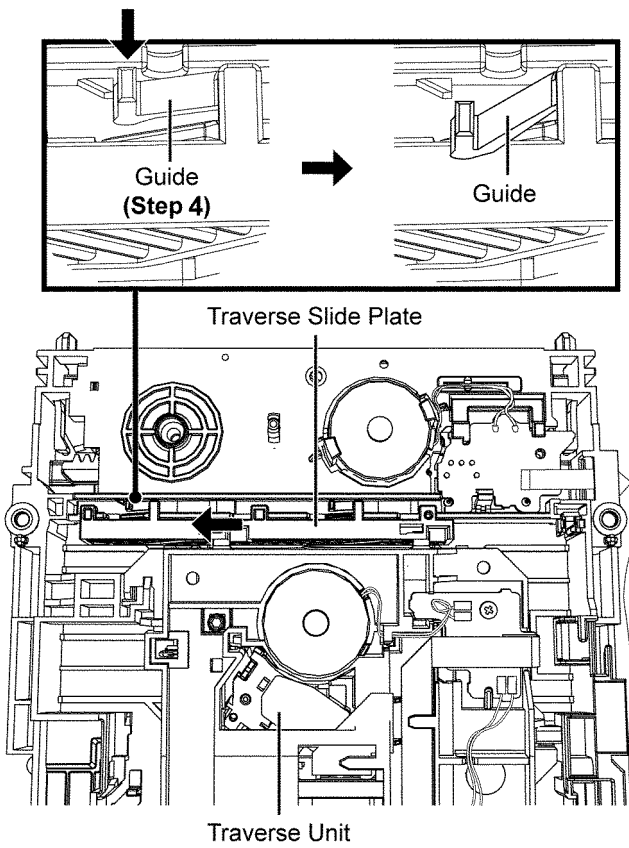

Step 6 : Lift up the Traverse Unit by approximately 45°.
Step 7 : Slide out the traverse unit as arrow shown.

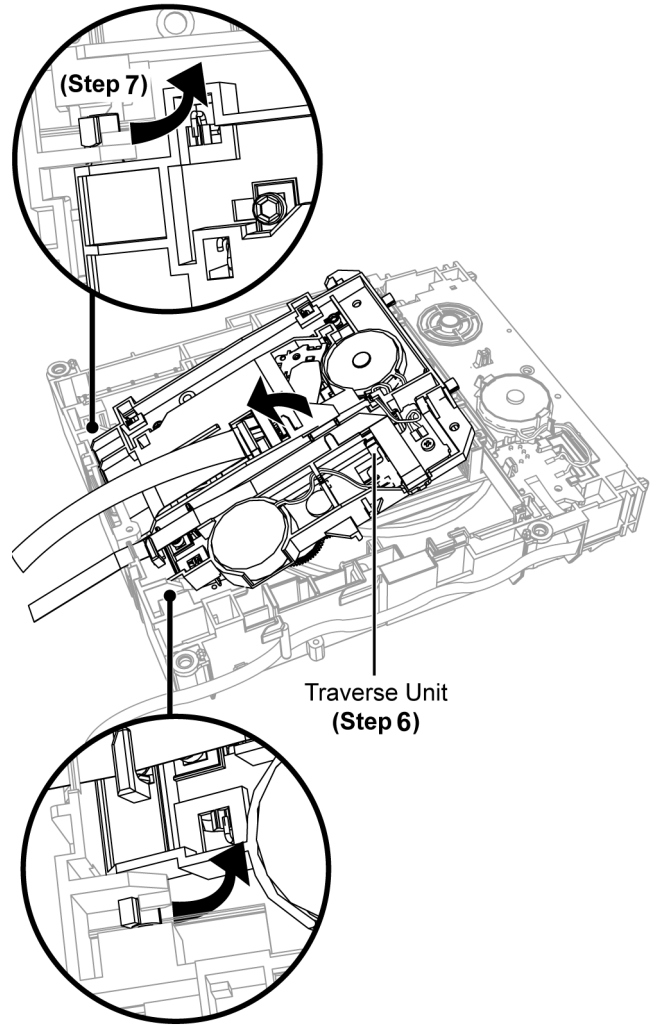

Step 5 : Release the 24P FFC from the slot.

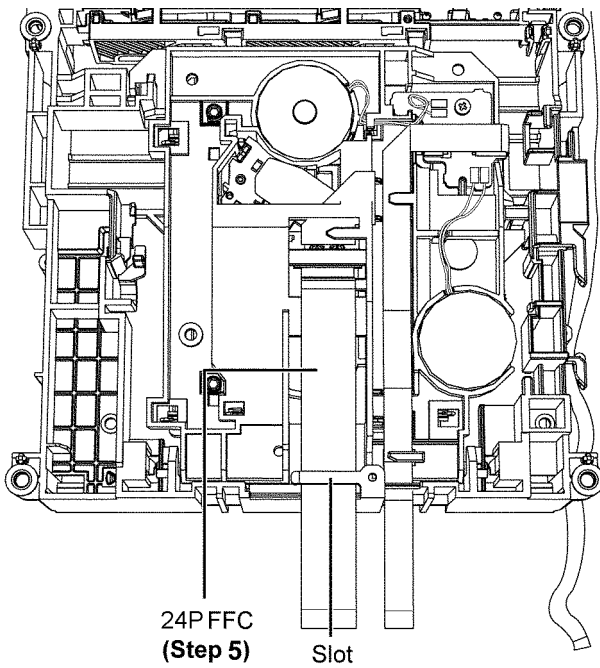

Caution : Avoid touching the surface of the OPU in the traverse unit.

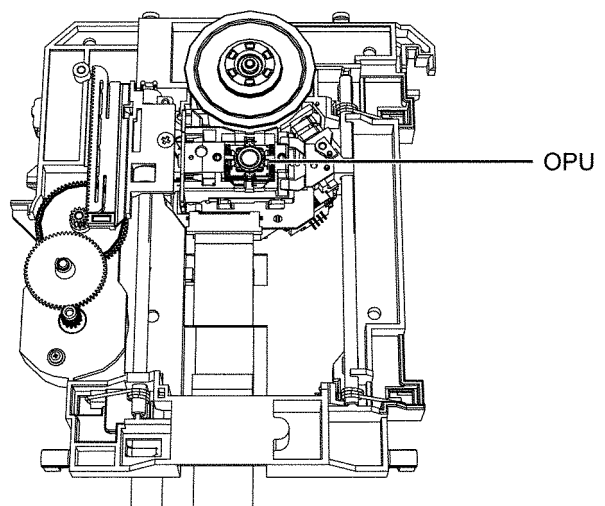

12.18.2. Assembly of Traverse Unit

Step 1 : Release the guide as shown & slide the Traverse Slide Plate to the end.

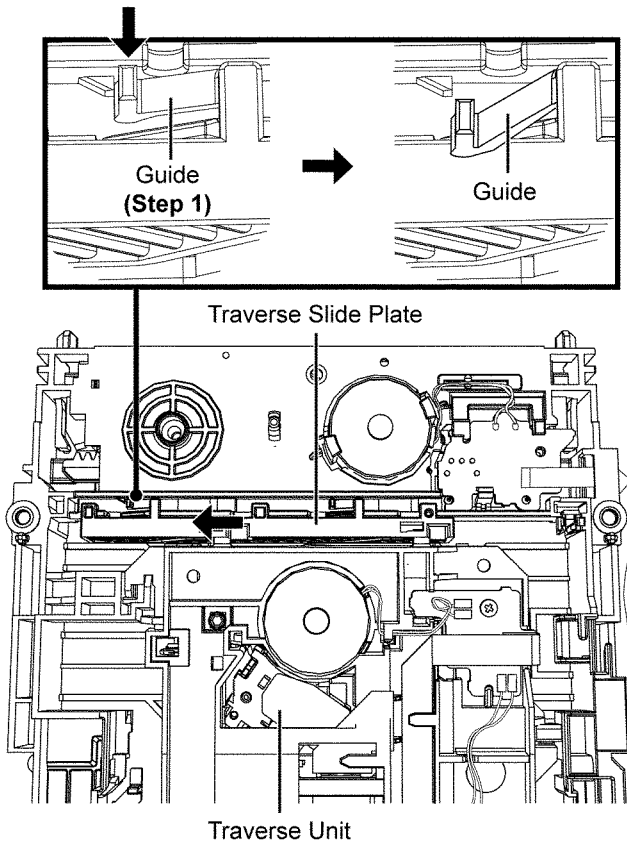

Step 2 : Insert the Traverse unit at approximately 45° into the mecha chassis as arrow shown.

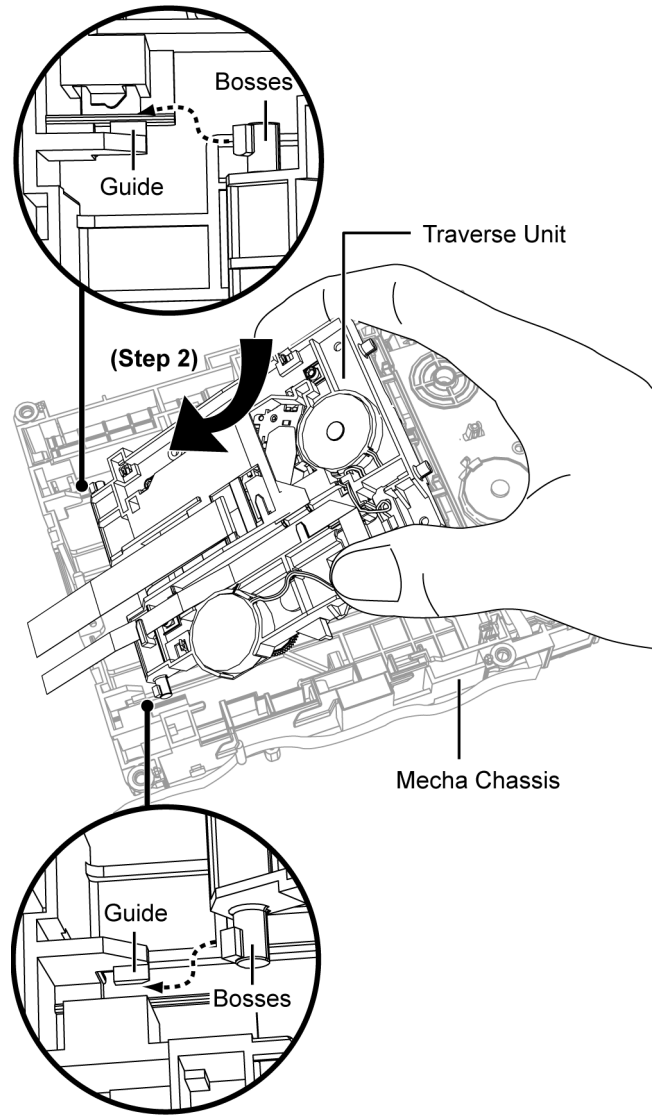

Step 3 : Insert the Traverse Unit into the grooves.

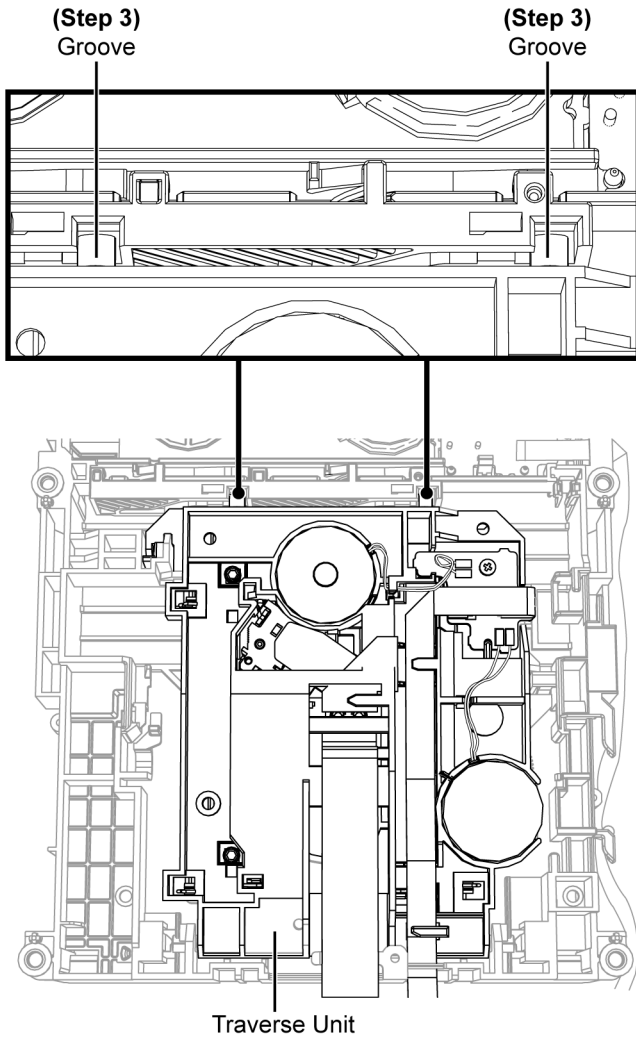

Step 4 : Slide the Traverse Slide Plate to lock the Traverse Unit as shown.

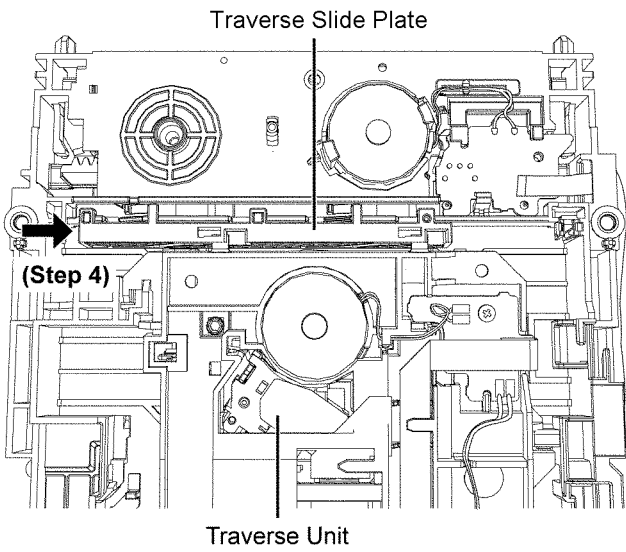

Step 5 : Insert the 24P FFC into the slot.

Caution : Ensure that the 24P FFC are properly inserted into the slots as shown.

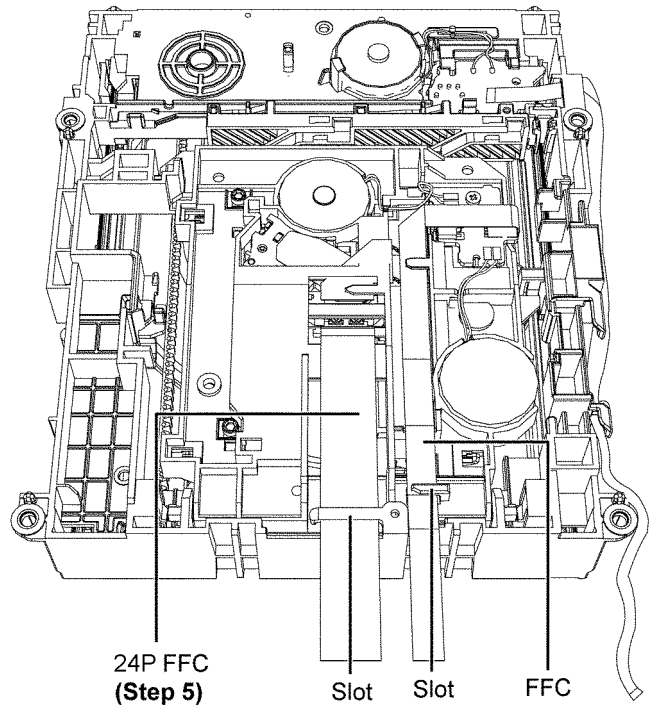

Step 6 : Slide the Traverse Slide Plate until it stop at the Guide.

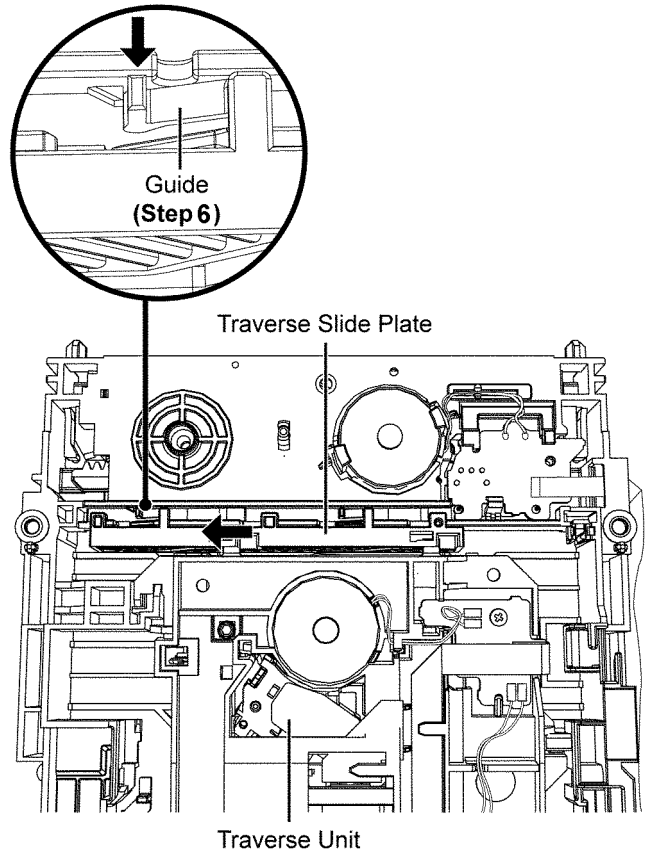

Step 7 Align and insert the grooves of the Tray into the Guides as shown.

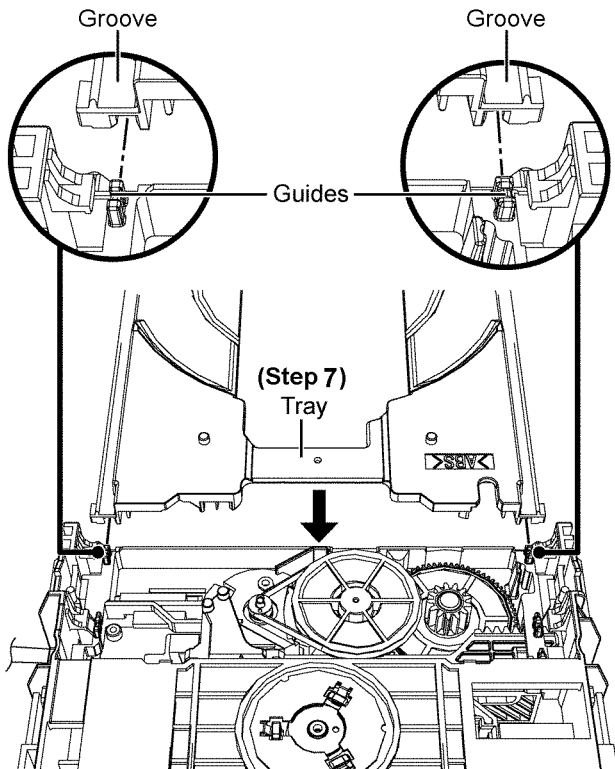

Step 9 Slide the tray in fully.

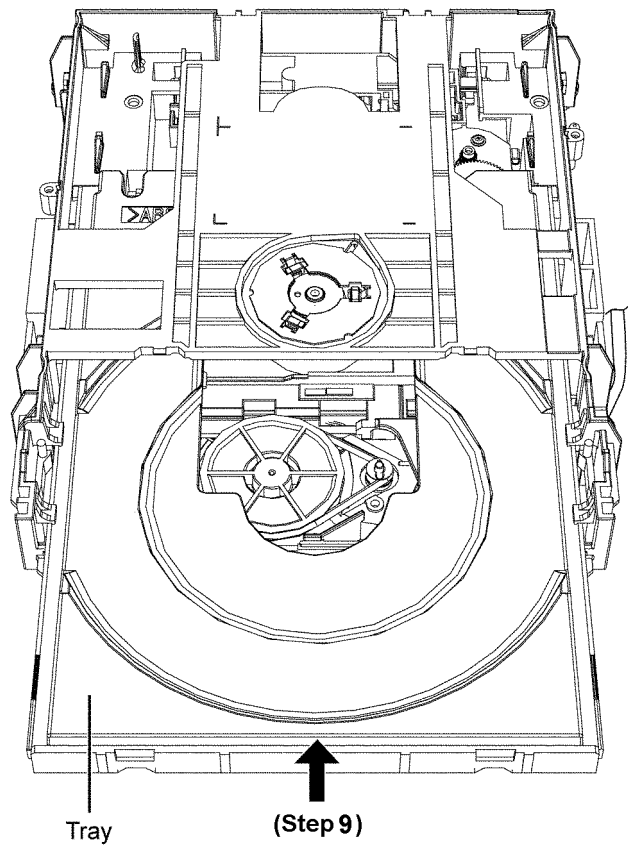

Step 8 Align the guides of the Traverse Slide Plate with the groove when sliding the tray in.

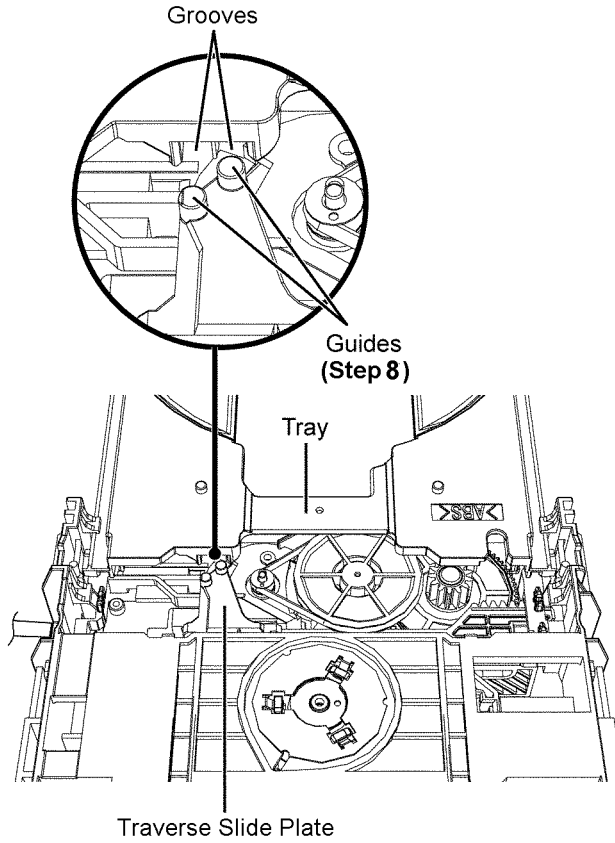

13 Service Position

Note: For description of the disassembly procedures, see the Section 12.

13.1. Checking & Repairing of Panel P.C.B.

- Step 1 Remove Top Cabinet.
- Step 2 Remove Tray Ornament.
- Step 3 Remove Front Panel Block Assembly.
- Step 4 Place the Front Panel Block Assembly on the insulated material as diagram shown.
- Step 5 Connect 17P FFC at the connector (CN203) on Main P.C.B..
- Step 6 Proceed to check and repair Panel P.C.B..

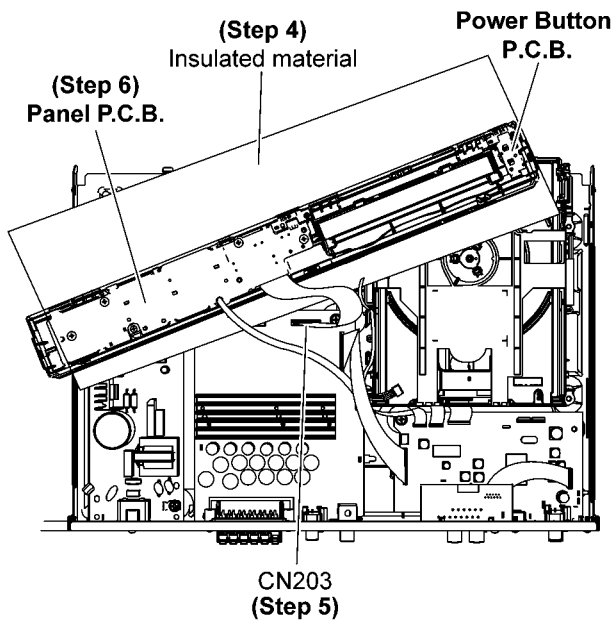

13.2. Checking & Repairing of SMPS P.C.B.

- Step 1 Remove Top Cabinet.
- Step 2 Remove SMPS P.C.B..
- Step 3 Place the SMPS P.C.B. on the insulated material.
- Step 4 Connect 12P cable at the connector (CN100) on Main P.C.B..
- Step 5 Proceed to check and repair SMPS P.C.B..

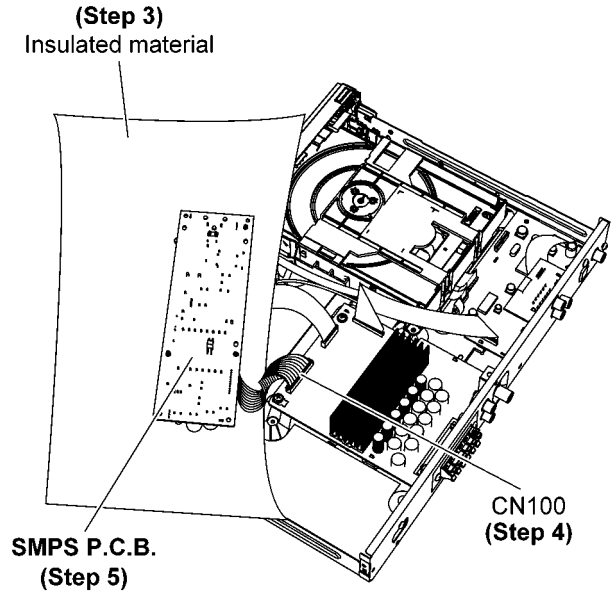

13.3. Checking & Repairing Main P.C.B.

13.3.1. Checking & Repairing Main P.C.B. (Side A)

- Step 1** Remove Top Cabinet.
- Step 2** Remove Main P.C.B..
- Step 3** Connect 12P Cable at the connector (CN100) on Main P.C.B..
- Step 4** Connect 17P FFC at the connector (CN203) on Main P.C.B..
- Step 5** Connect 50P Extension FFC (RFKZXH150PK2) from (CN201) to (FP8101).

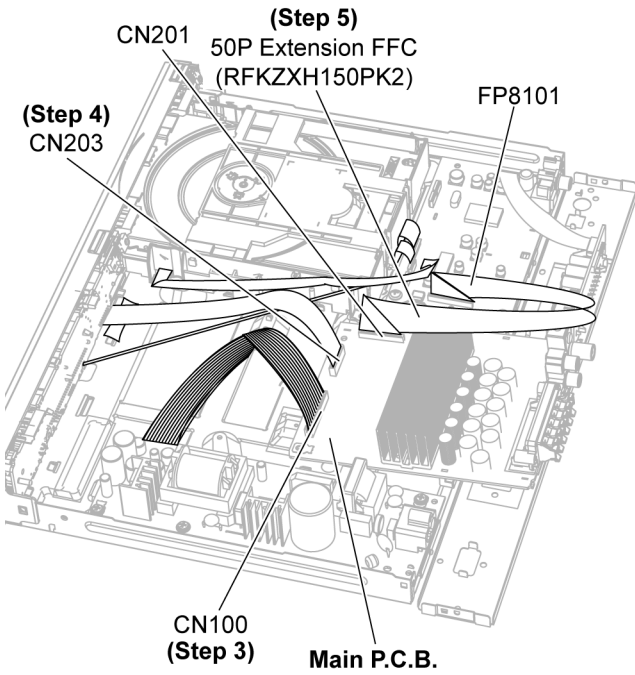

Step 6 Upset the Main P.C.B. and place it onto the insulated material.

Step 7 Proceed to check and repair side A of Main P.C.B..

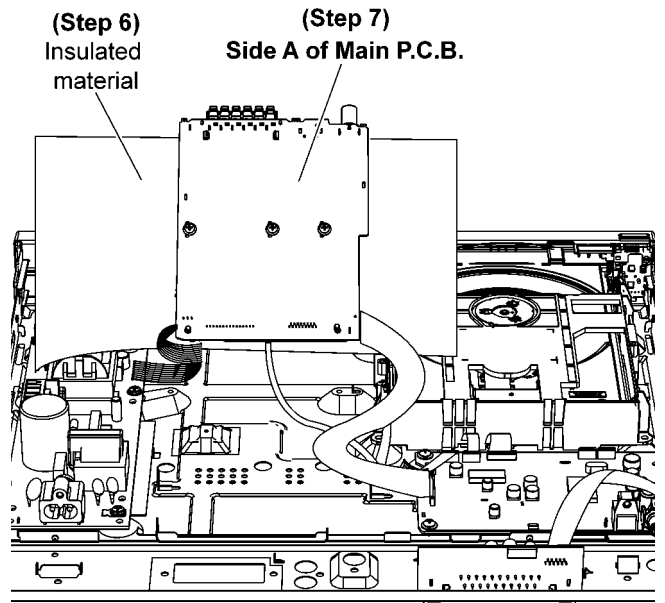

13.3.2. Checking & Repairing Main P.C.B. (Side B)

- Step 1** Remove Top Cabinet.
- Step 2** Remove Main P.C.B..
- Step 3** Remove 3 screws.

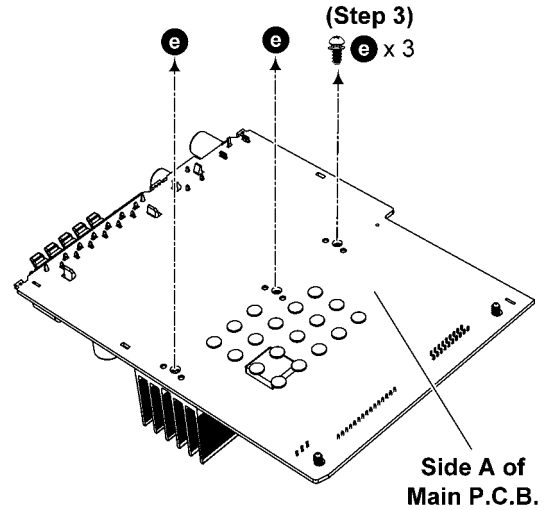

Step 4 Lift up the Main P.C.B. as arrow shown.

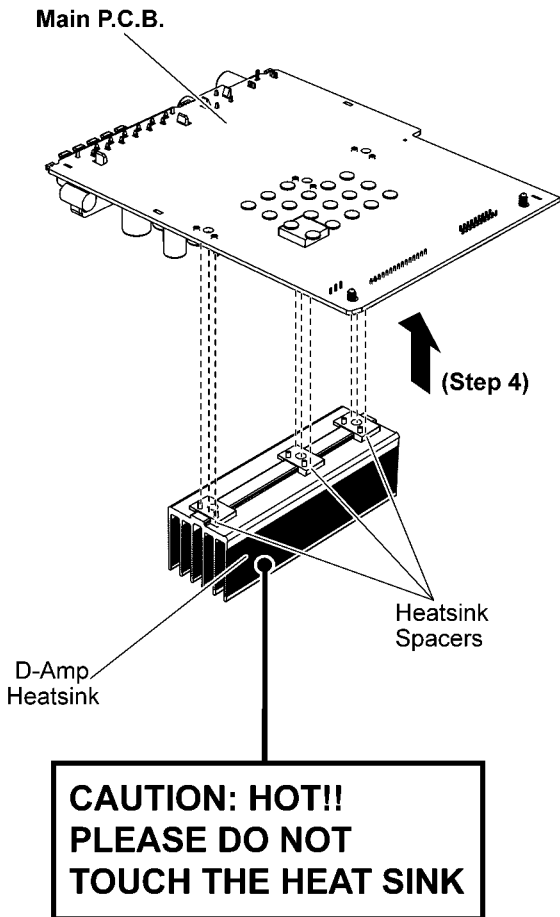

Step 5 Place the Main P.C.B. back to original position.

Step 6 Connect 12P Cable at the connector (CN100) on Main P.C.B..

Step 7 Connect 17P FFC at the connector (CN203) on Main P.C.B..

Step 8 Connect 50P FFC at the connector (CN201) on Main P.C.B..

Step 9 Proceed to check & repair Side B of Main P.C.B..

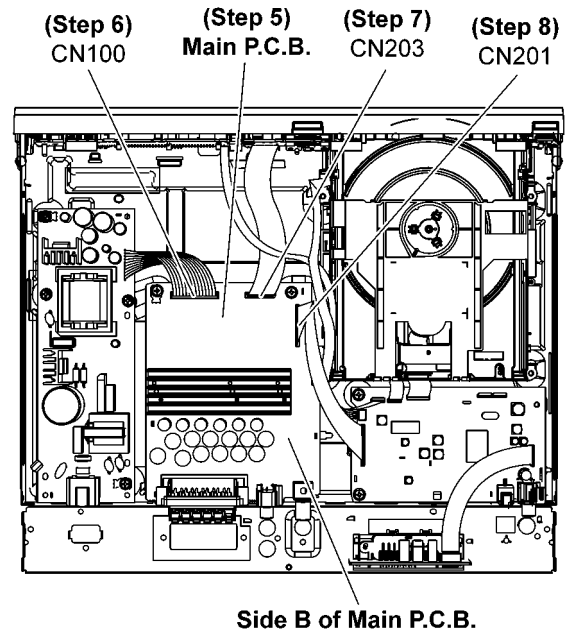

13.4. Checking & Repairing of Back-end P.C.B.

13.4.1. Checking & Repairing of Backend P.C.B. (Side B)

Step 1 Remove Top Cabinet.

Step 2 Remove Component Video P.C.B..

Step 3 Connect 11P FFC at the connector (FP8301) on Back-end P.C.B..

Step 4 Proceed to check & repair Side B of Backend P.C.B..

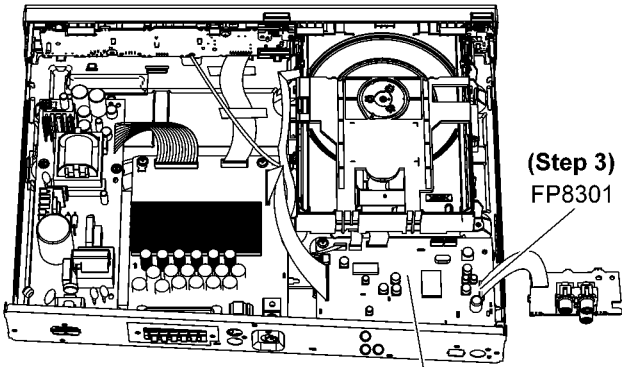

Side B of Backend P.C.B. (Step 4)

Step 4 Remove 2 screws.

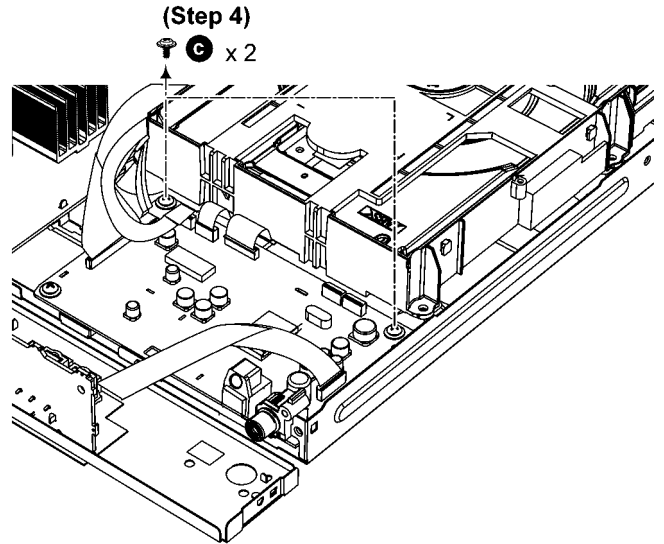

Step 5 Upset the Backend P.C.B. and position it onto insulated material as diagram shown.

Step 6 Proceed to check and repair Side A of Backend P.C.B..

13.4.2. Checking & Repairing of Backend P.C.B. (Side A)

Step 1 Remove Top Cabinet.

Step 2 Remove 8 screws.

Step 3 Release the 2 tabs at each side of the Rear Panel in the direction of arrow.

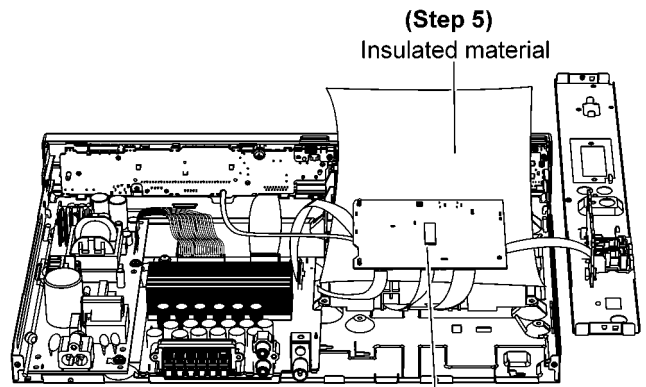
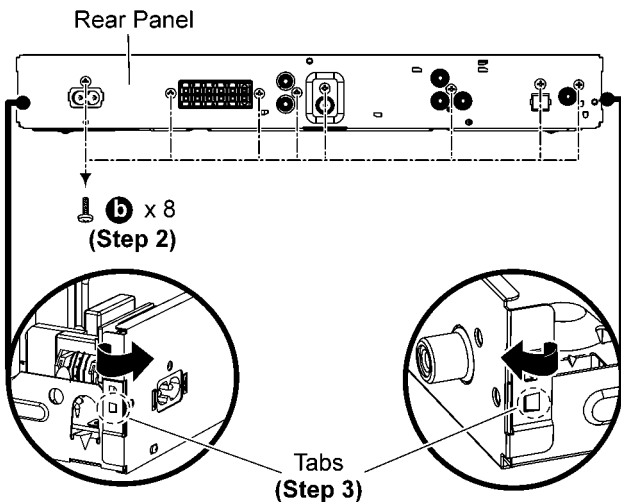

Side A of Backend P.C.B. (Step 6)

14 Overall Simplified Block Diagram

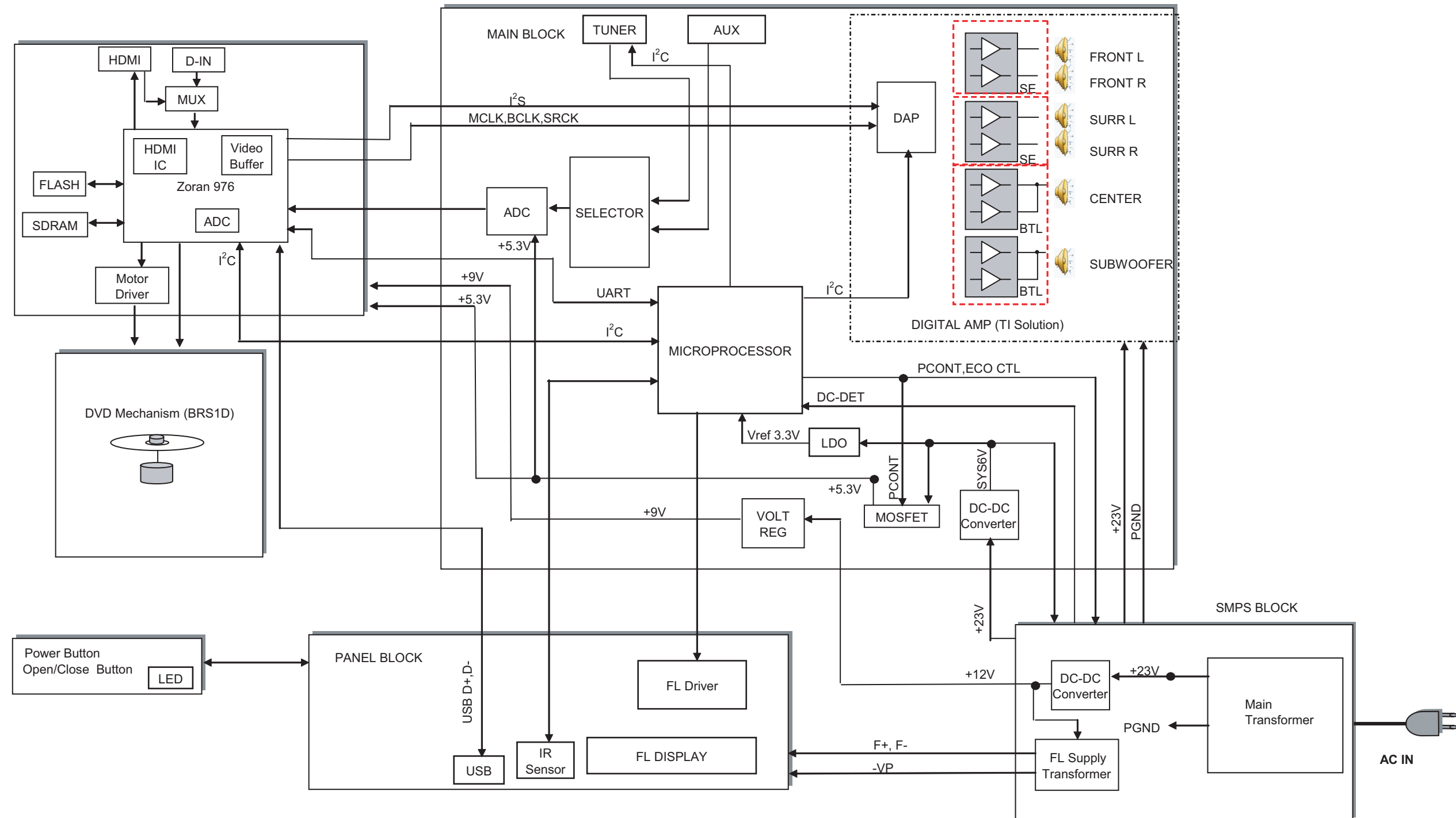

15 Block Diagram

15.1. Backend

: CD/DVD AUDIO INPUT SIGNAL LINE
 : OPTICAL/AUX/TUNER AUDIO INPUT SIGNAL LINE
 : CD/DVD VIDEO INPUT SIGNAL LINE
 : AUDIO OUTPUT SIGNAL LINE
 : VIDEO OUTPUT SIGNAL LINE
 : USB SIGNAL LINE

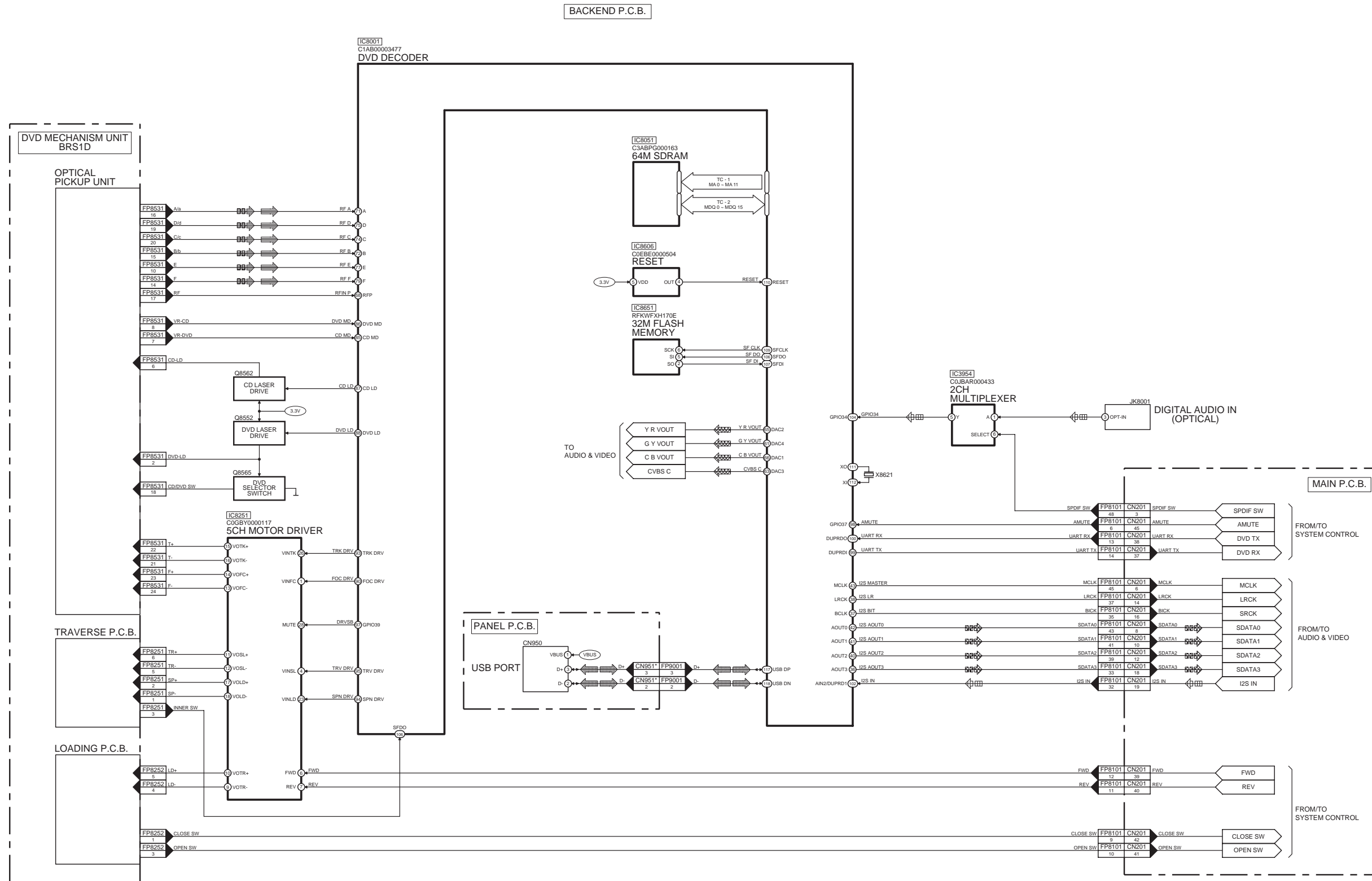

NOTE: "*" REF IS FOR INDICATION ONLY

SA-XH20PH BACKEND BLOCK DIAGRAM

15.2. IC Terminal Chart

TC	IC8001 DVD DECODER		SIGNAL NAME	IC8051 64M SDRAM	
	PORT NAME	PIN NO		PIN NO	PORT NAME
1	MA0	1	MA 0	23	A0
	MA1	126	MA 1	24	A1
	MA2	124	MA 2	25	A2
	MA3	122	MA 3	26	A3
	MA4	121	MA 4	29	A4
	MA5	123	MA 5	30	A5
	MA6	125	MA 6	31	A6
	MA7	127	MA 7	32	A7
	MA8	3	MA 8	33	A8
	MA9	5	MA 9	34	A9
	MA10	4	MA 10	22	A10
MA11	6	MA 11	35	A11	

TC	IC8001 DVD DECODER		SIGNAL NAME	IC8051 64M SDRAM	
	PORT NAME	PIN NO		PIN NO	PORT NAME
2	DQ0	33	MDQ 0	2	DQ0
	DQ1	31	MDQ 1	4	DQ1
	DQ2	29	MDQ 2	5	DQ2
	DQ3	26	MDQ 3	7	DQ3
	DQ4	24	MDQ 4	8	DQ4
	DQ5	22	MDQ 5	10	DQ5
	DQ6	20	MDQ 6	11	DQ6
	DQ7	18	MDQ 7	13	DQ7
	DQ8	17	MDQ 8	42	DQ8
	DQ9	19	MDQ 9	44	DQ9
	DQ10	21	MDQ 10	45	DQ10
	DQ11	23	MDQ 11	47	DQ11
	DQ12	25	MDQ 12	48	DQ12
	DQ13	28	MDQ 13	50	DQ13
	DQ14	30	MDQ 14	51	DQ14
DQ15	32	MDQ 15	53	DQ15	

15.3. System Control

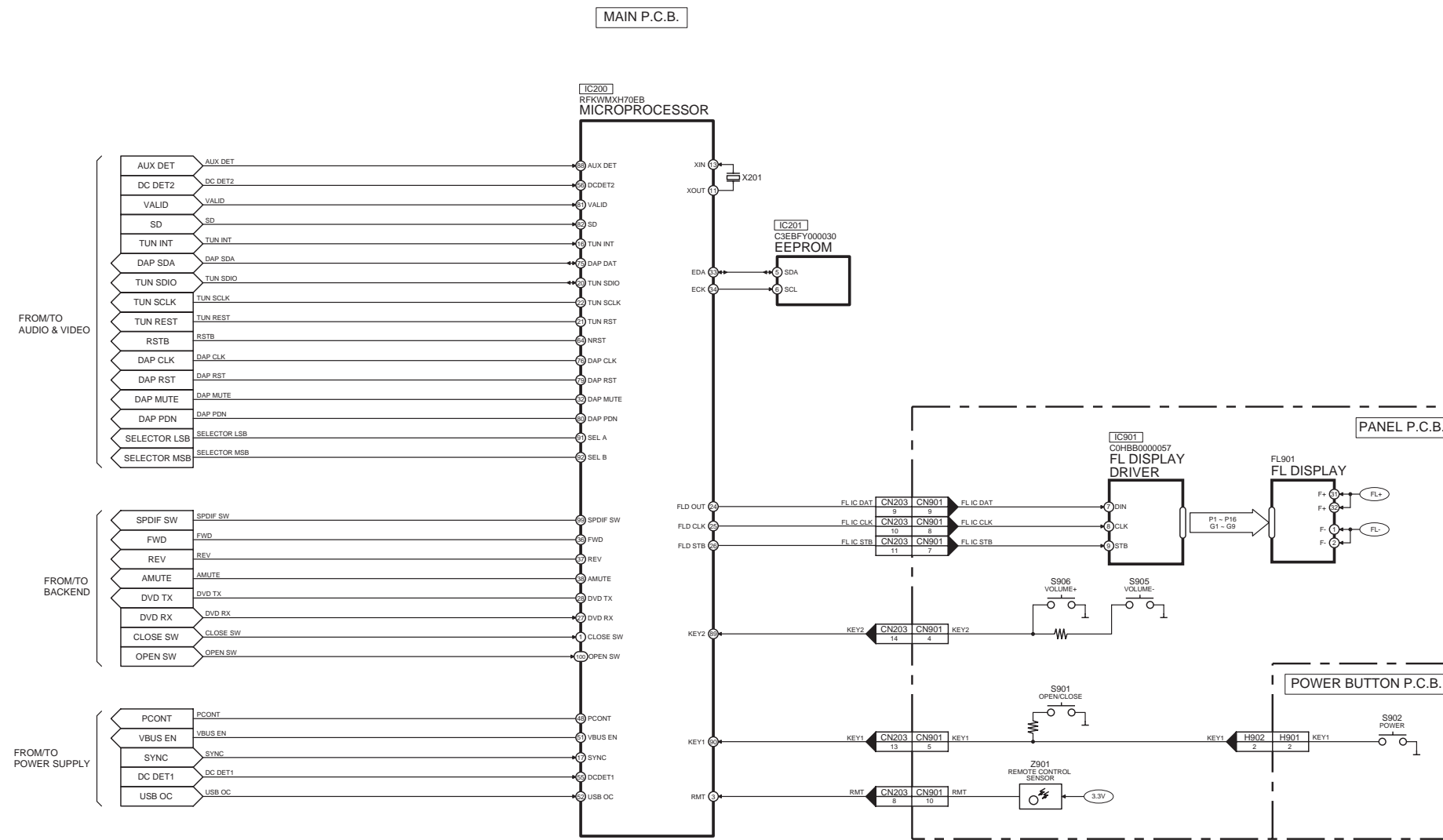

SA-XH20PH SYSTEM CONTROL BLOCK DIAGRAM

15.4. Audio and Video

: AUX/TUNER AUDIO INPUT SIGNAL LINE
 : AUDIO OUTPUT SIGNAL LINE
 : VIDEO OUTPUT SIGNAL LINE
 : FM SIGNAL LINE

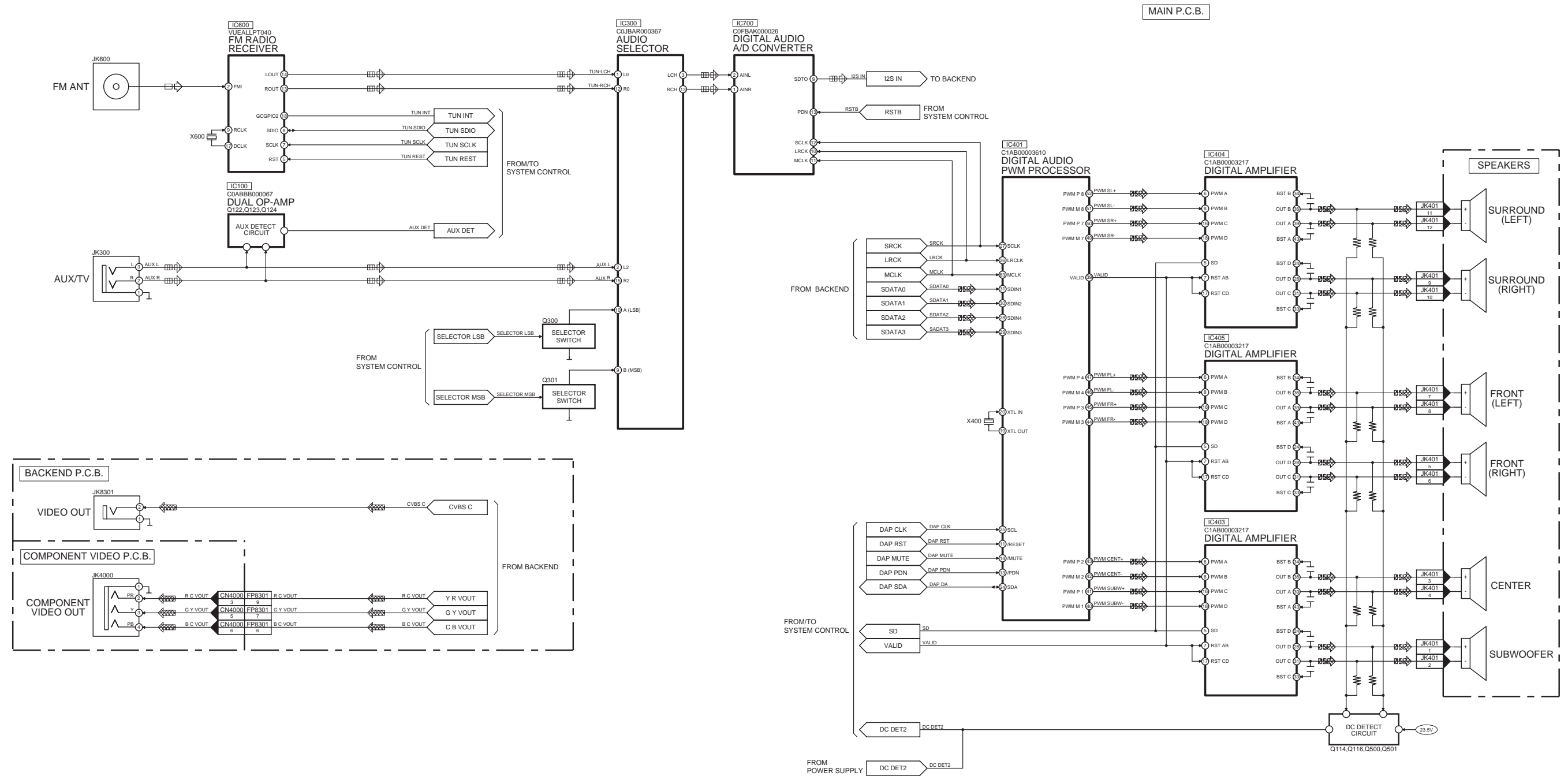

SA-XH20PH AUDIO & VIDEO BLOCK DIAGRAM

15.5. Power Supply

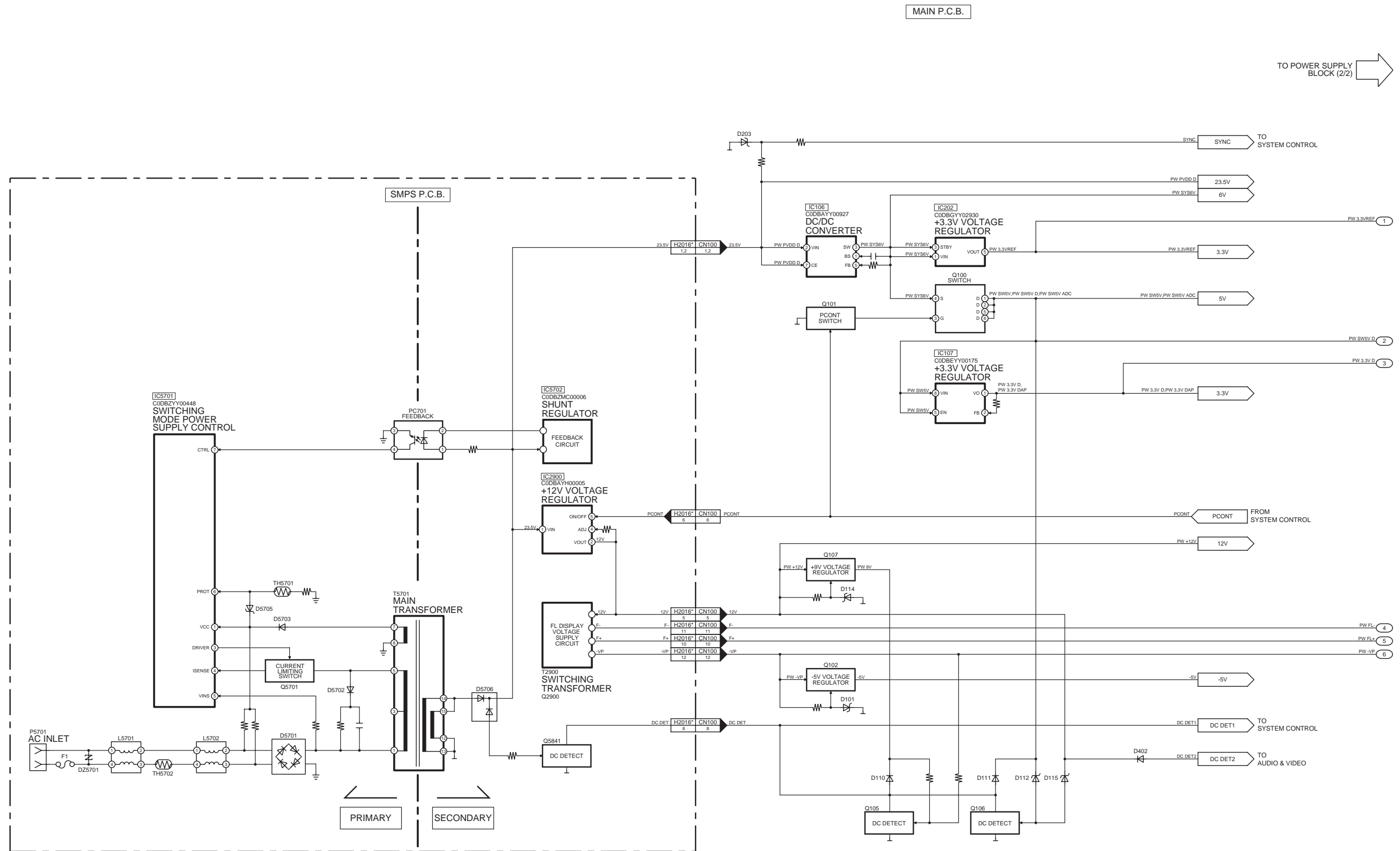

NOTE: "*" REF IS FOR INDICATION ONLY

SA-XH20PH POWER SUPPLY (1/2) BLOCK DIAGRAM

MAIN P.C.B.

← TO POWER SUPPLY BLOCK (1/2)

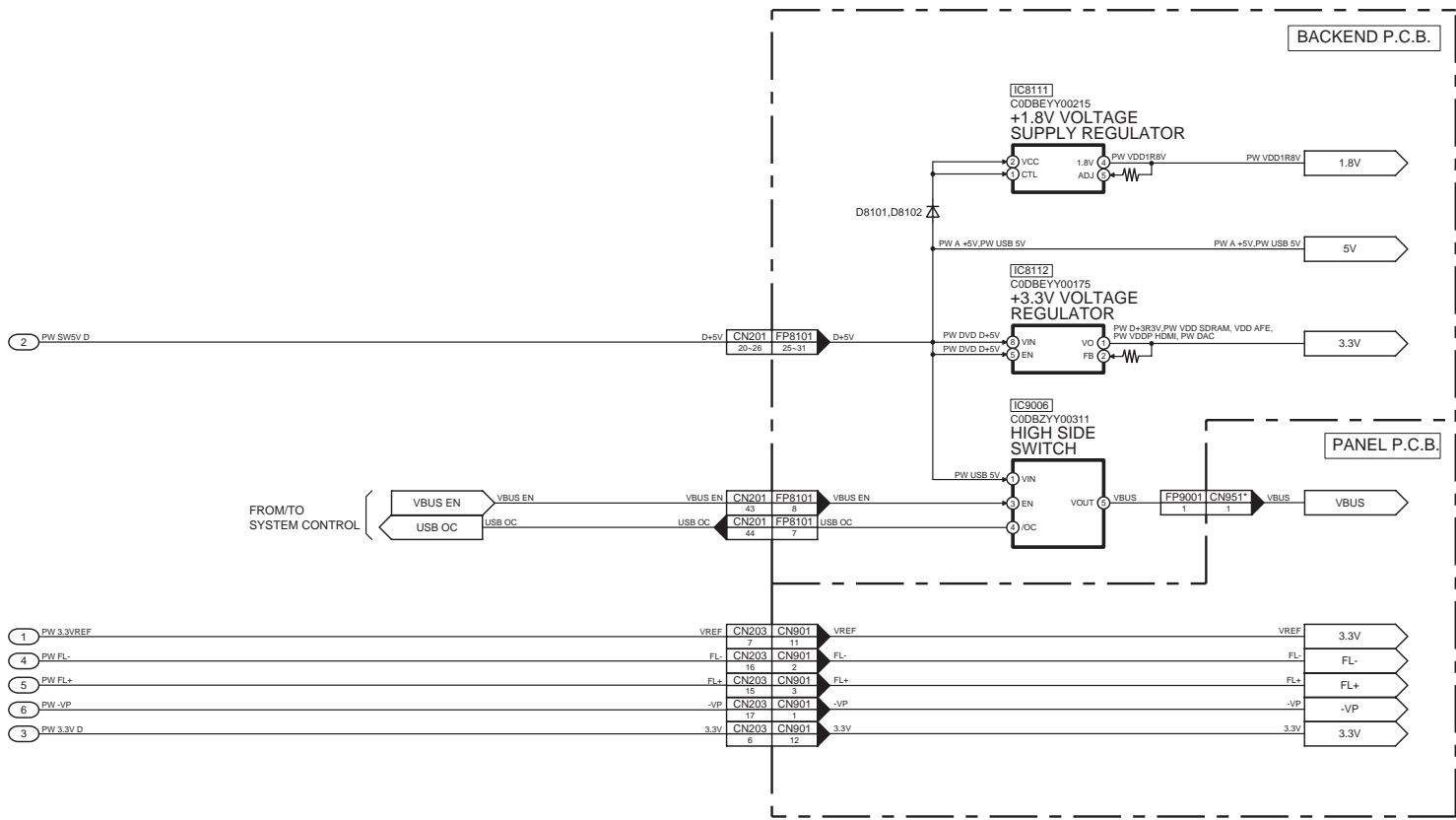

NOTE: " * " REF IS FOR INDICATION ONLY

SA-XH20PH POWER SUPPLY (2/2) BLOCK DIAGRAM

16 Wiring Connection Diagram

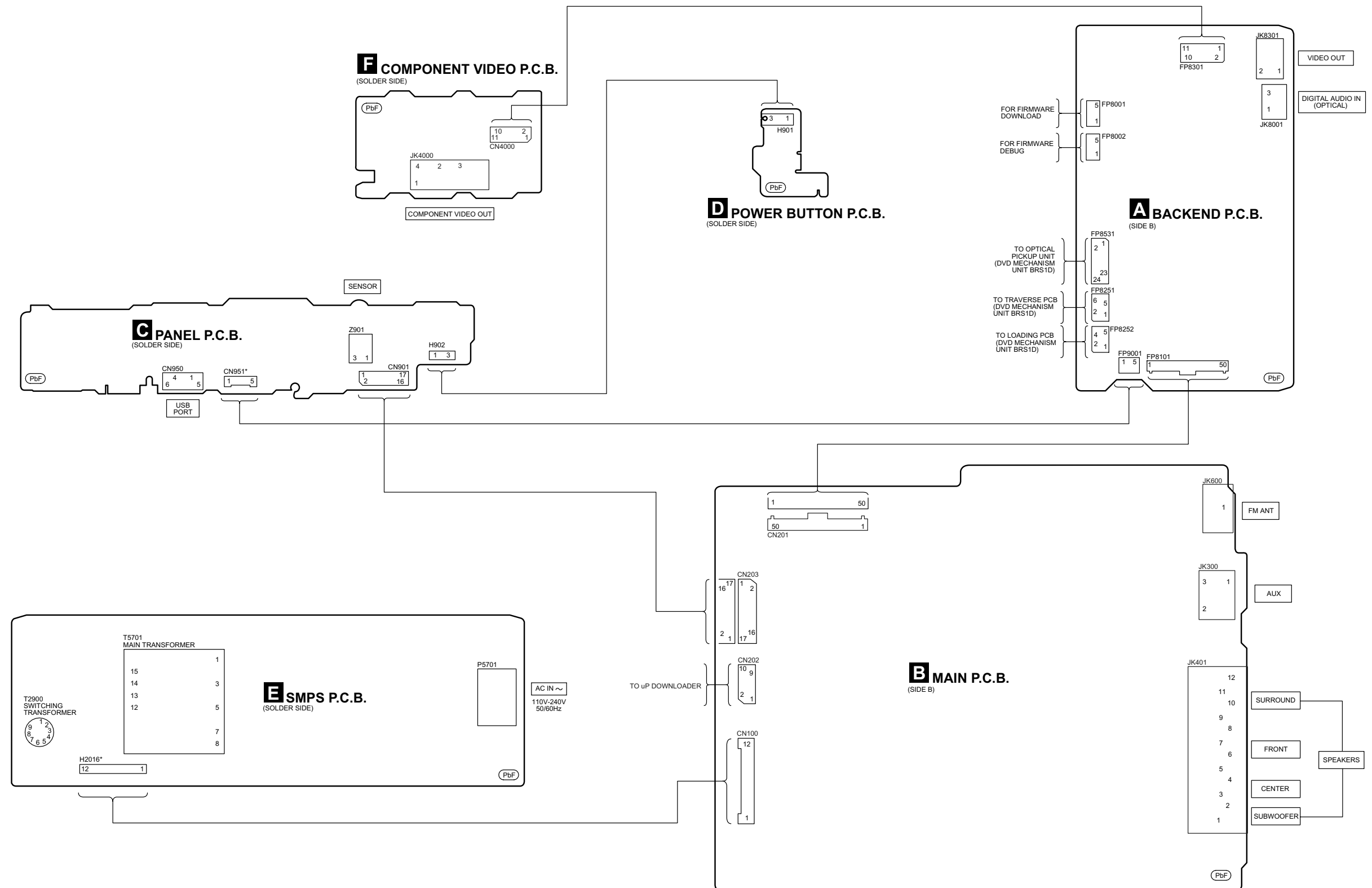

NOTE: " * " REF IS FOR INDICATION ONLY.

SA-XH20PH WIRING CONNECTION DIAGRAM

17 Schematic Diagram

17.1. Schematic Diagram Notes

- This schematic diagram may be modified at any time with the development of new technology.

Notes:

- S901:** Open/Close switch (▲).
- S902:** Power switch (⏻/⏻).
- S905:** Vol (-) switch.
- S906:** Vol (+) switch.

- Important safety notice:
Components identified by ▲ mark have special characteristics important for safety.
Furthermore, special parts which have purposes of fire-retardant (resistors), high quality sound (capacitors), low-noise (resistors), etc are used.
When replacing any of components, be sure to use only manufacturer's specified parts shown in the parts list.

- In case of AC rated voltage Capacitors, the part no. and values will be indicated in the Schematic Diagram.
AC rated voltage capacitors:
C5702, C5703, C5704, C5705, C5706









- **Resistor**
Unit of resistance is OHM [Ω] (K=1,000, M=1,000,000).

- **Capacitor**
Unit of capacitance is μF, unless otherwise noted. F=Farads, pF=pico-Farad.

- **Coil**
Unit of inductance is H, unless otherwise noted.

- *
REF is for indication only.

• Voltage and signal line

-  : +B signal line
-  : -B signal line
-  : Audio output signal line
-  : Video output signal line
-  : CD/DVD Audio input signal line
-  : CD/DVD Video input signal line
-  : AUX/Tuner/Optical Audio input signal line
-  : FM signal line
-  : USB signal line

CAUTION: FOR CONTINUED PROTECTION AGAINST FIRE HAZARD, REPLACE ONLY WITH SAME TYPE F1 T3.15A 250V FUSE



RISK OF FIRE-REPLACE FUSE AS MARKED.

FUSE CAUTION



These symbols located near the fuse indicates that the fuse used is a fast operating type. For continued protection against fire hazard, replace with the same type fuse. For rating, refer to the marking adjacent to the symbol.

17.2. Backend Circuit

SCHEMATIC DIAGRAM - 1

A BACKEND CIRCUIT

—: +B SIGNAL LINE : CD/DVD AUDIO INPUT SIGNAL LINE : CD/DVD VIDEO INPUT SIGNAL LINE : AUX/TUNER/OPTICAL AUDIO INPUT SIGNAL LINE : AUDIO OUTPUT SIGNAL LINE : VIDEO OUTPUT SIGNAL LINE : USB SIGNAL LINE

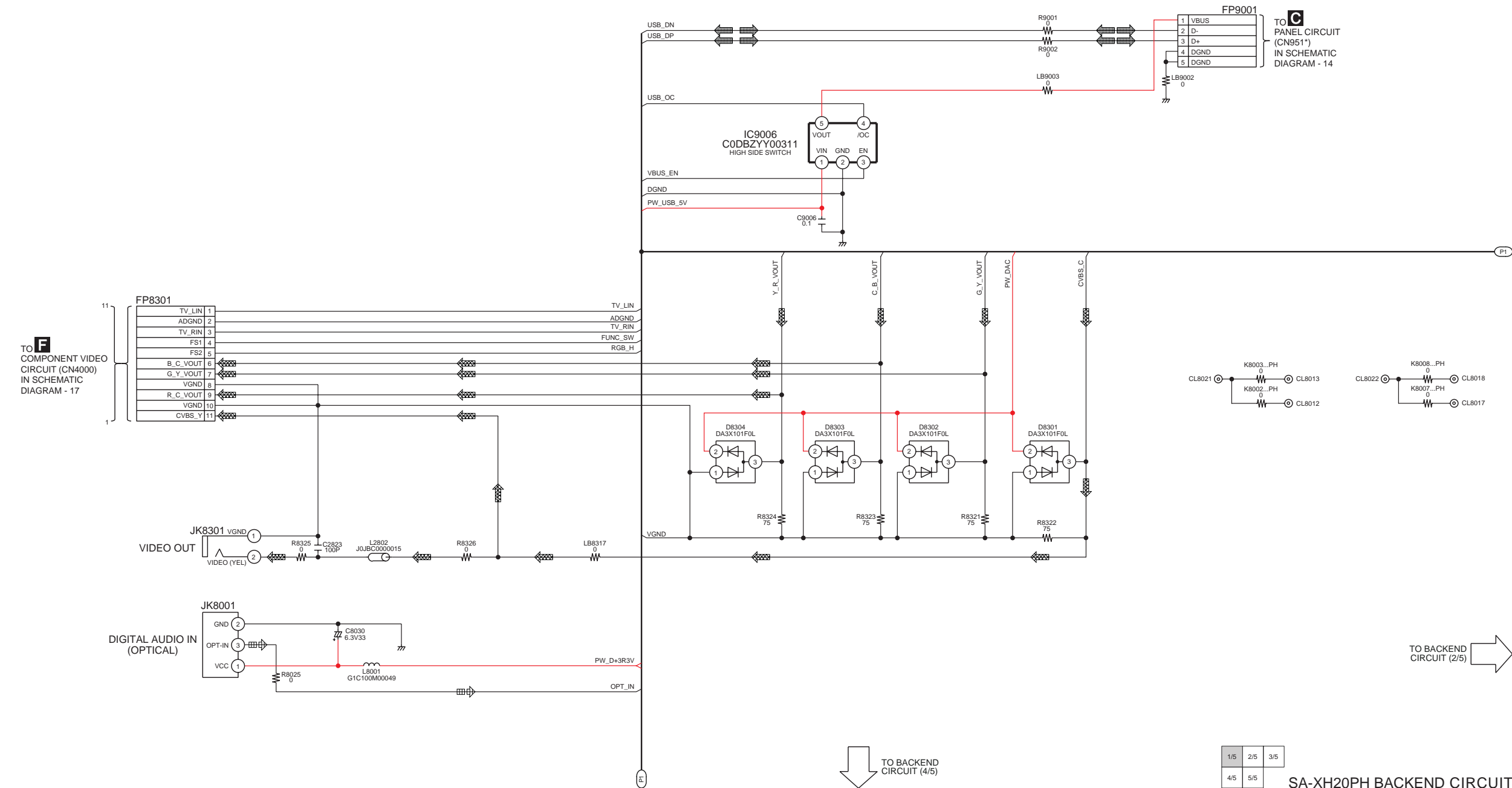

1/5	2/5	3/5
4/5	5/5	

SA-XH20PH BACKEND CIRCUIT

SCHEMATIC DIAGRAM - 2 A BACKEND CIRCUIT

— : +B SIGNAL LINE : CD/DVD AUDIO INPUT SIGNAL LINE : CD/DVD VIDEO INPUT SIGNAL LINE : AUX/TUNER/OPTICAL AUDIO INPUT SIGNAL LINE : AUDIO OUTPUT SIGNAL LINE : VIDEO OUTPUT SIGNAL LINE : USB SIGNAL LINE

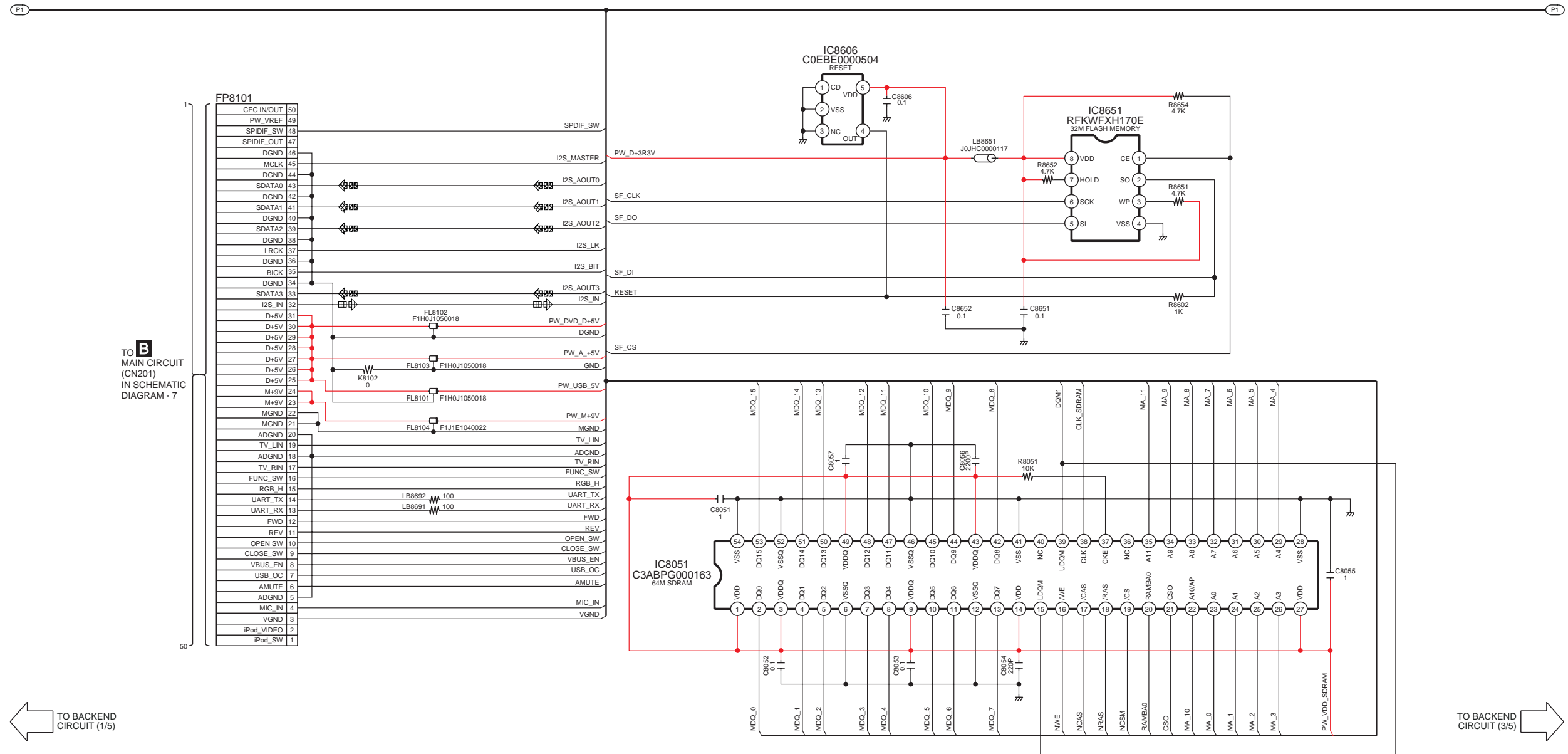

TO **B** MAIN CIRCUIT (CN201) IN SCHEMATIC DIAGRAM - 7

← TO BACKEND CIRCUIT (1/5)

→ TO BACKEND CIRCUIT (3/5)

↓ TO BACKEND CIRCUIT (5/5)

SCHEMATIC DIAGRAM - 4

A BACKEND CIRCUIT

— : +B SIGNAL LINE : CD/DVD AUDIO INPUT SIGNAL LINE : CD/DVD VIDEO INPUT SIGNAL LINE : AUX/TUNER/OPTICAL AUDIO INPUT SIGNAL LINE : AUDIO OUTPUT SIGNAL LINE : VIDEO OUTPUT SIGNAL LINE : USB SIGNAL LINE

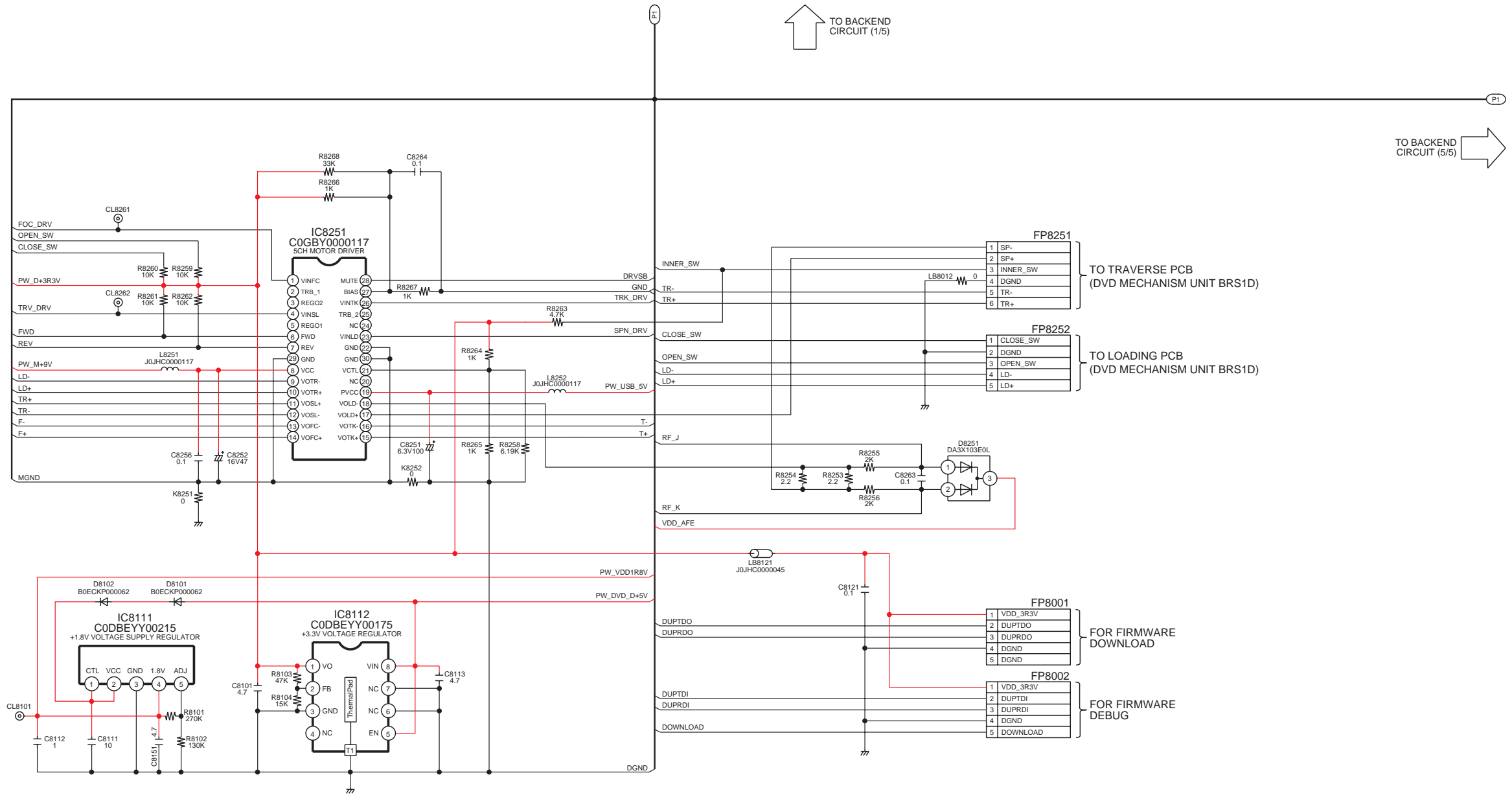

1/5	2/5	3/5
4/5	5/5	

SA-XH20PH BACKEND CIRCUIT

SCHEMATIC DIAGRAM - 5
A BACKEND CIRCUIT

—: +B SIGNAL LINE : CD/DVD AUDIO INPUT SIGNAL LINE : CD/DVD VIDEO INPUT SIGNAL LINE : AUX/TUNER/OPTICAL AUDIO INPUT SIGNAL LINE : AUDIO OUTPUT SIGNAL LINE : VIDEO OUTPUT SIGNAL LINE : USB SIGNAL LINE

↑ TO BACKEND CIRCUIT (2/5)

← TO BACKEND CIRCUIT (4/5)

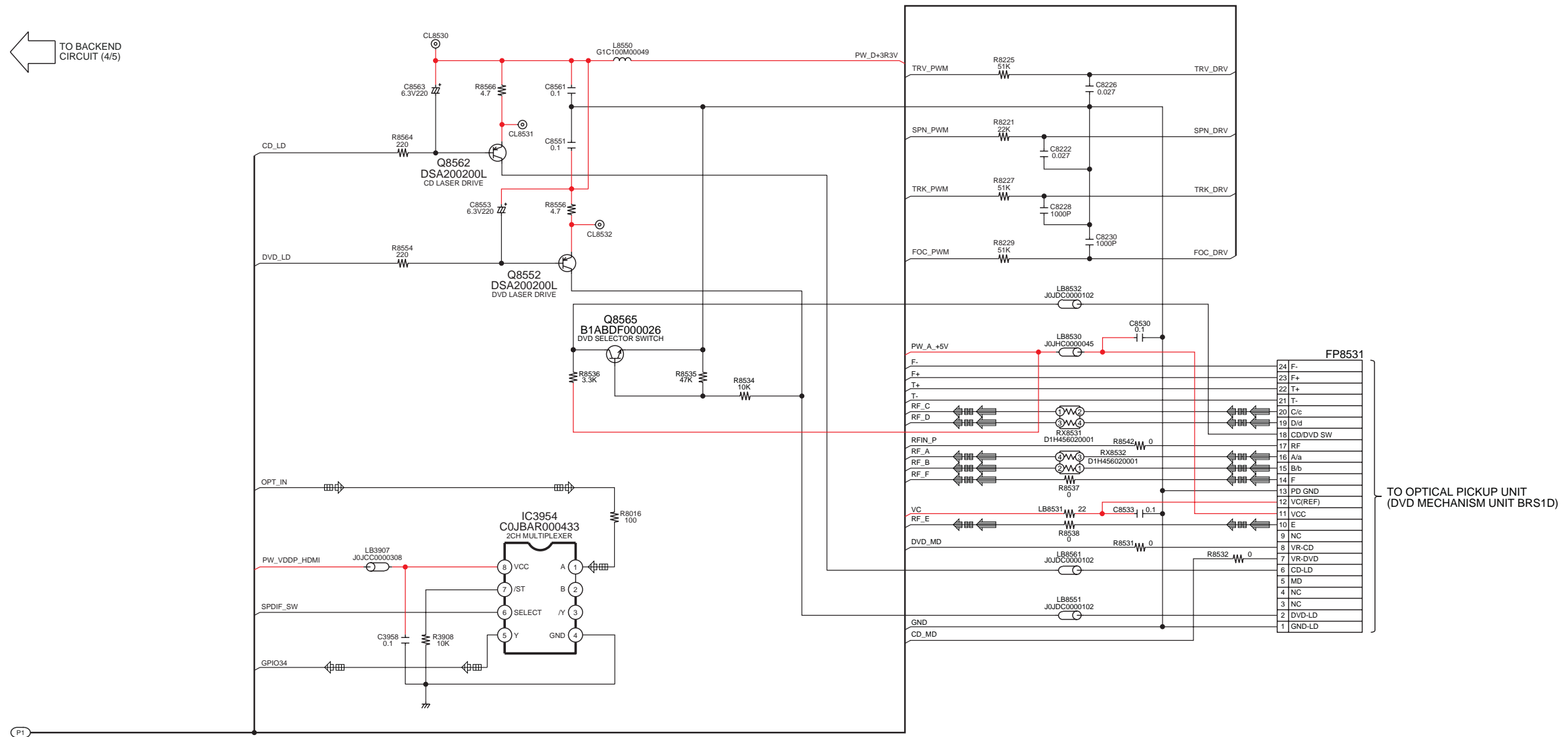

1/5 2/5 3/5
4/5 5/5

SA-XH20PH BACKEND CIRCUIT

15 16 17 18 19 20 21 22 23 24 25 26 27 28

17.3. Main Circuit

SCHEMATIC DIAGRAM - 6

B MAIN CIRCUIT

— : +B SIGNAL LINE — : -B SIGNAL LINE  : AUX/TUNER AUDIO INPUT SIGNAL LINE  : AUDIO OUTPUT SIGNAL LINE  : FM SIGNAL LINE

TO MAIN CIRCUIT (2/8) 

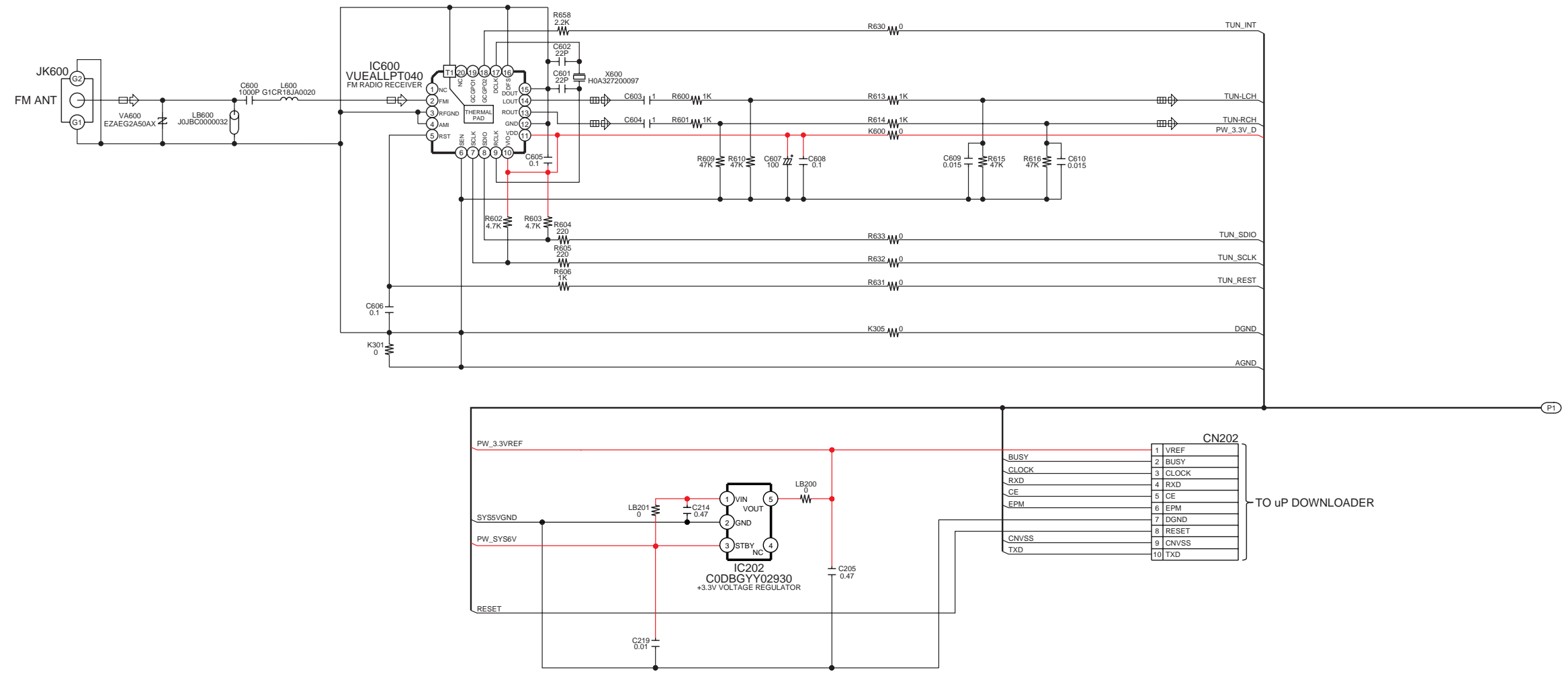

TO MAIN CIRCUIT (5/8) 

1/8	2/8	3/8	4/8
5/8	6/8	7/8	8/8

SA-XH20PH MAIN CIRCUIT

B MAIN CIRCUIT

— : +B SIGNAL LINE - - - : -B SIGNAL LINE □◁▷ : AUX/TUNER AUDIO INPUT SIGNAL LINE ◁▷◁▷ : AUDIO OUTPUT SIGNAL LINE □◁▷ : FM SIGNAL LINE

← TO MAIN CIRCUIT (1/8)

TO **A** BACKEND CIRCUIT (FPB101) IN SCHEMATIC DIAGRAM - 2

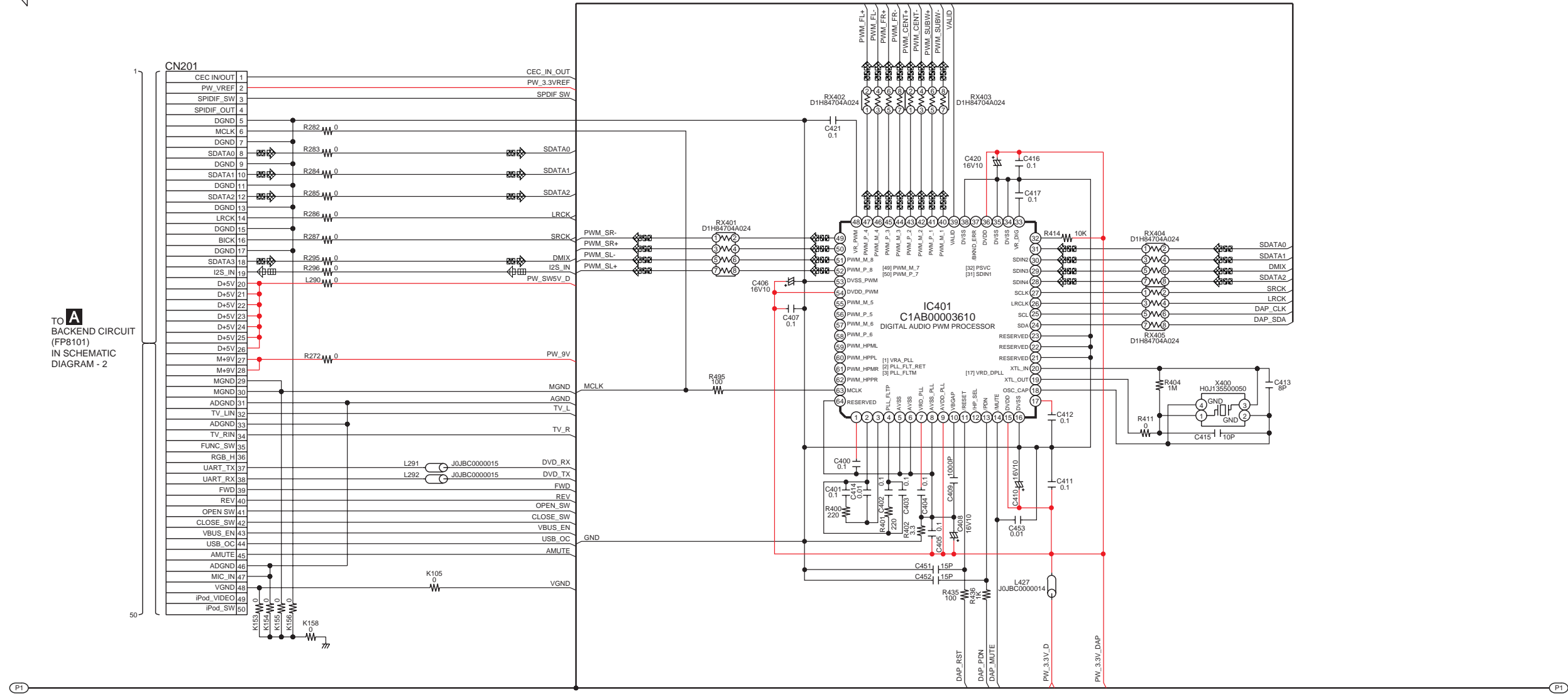

↓ TO MAIN CIRCUIT (6/8)

TO MAIN CIRCUIT (3/8) →

1/8	2/8	3/8	4/8
5/8	6/8	7/8	8/8

SA-XH20PH MAIN CIRCUIT

SCHEMATIC DIAGRAM - 8

B MAIN CIRCUIT

— : +B SIGNAL LINE — : -B SIGNAL LINE : AUX/TUNER AUDIO INPUT SIGNAL LINE : AUDIO OUTPUT SIGNAL LINE : FM SIGNAL LINE

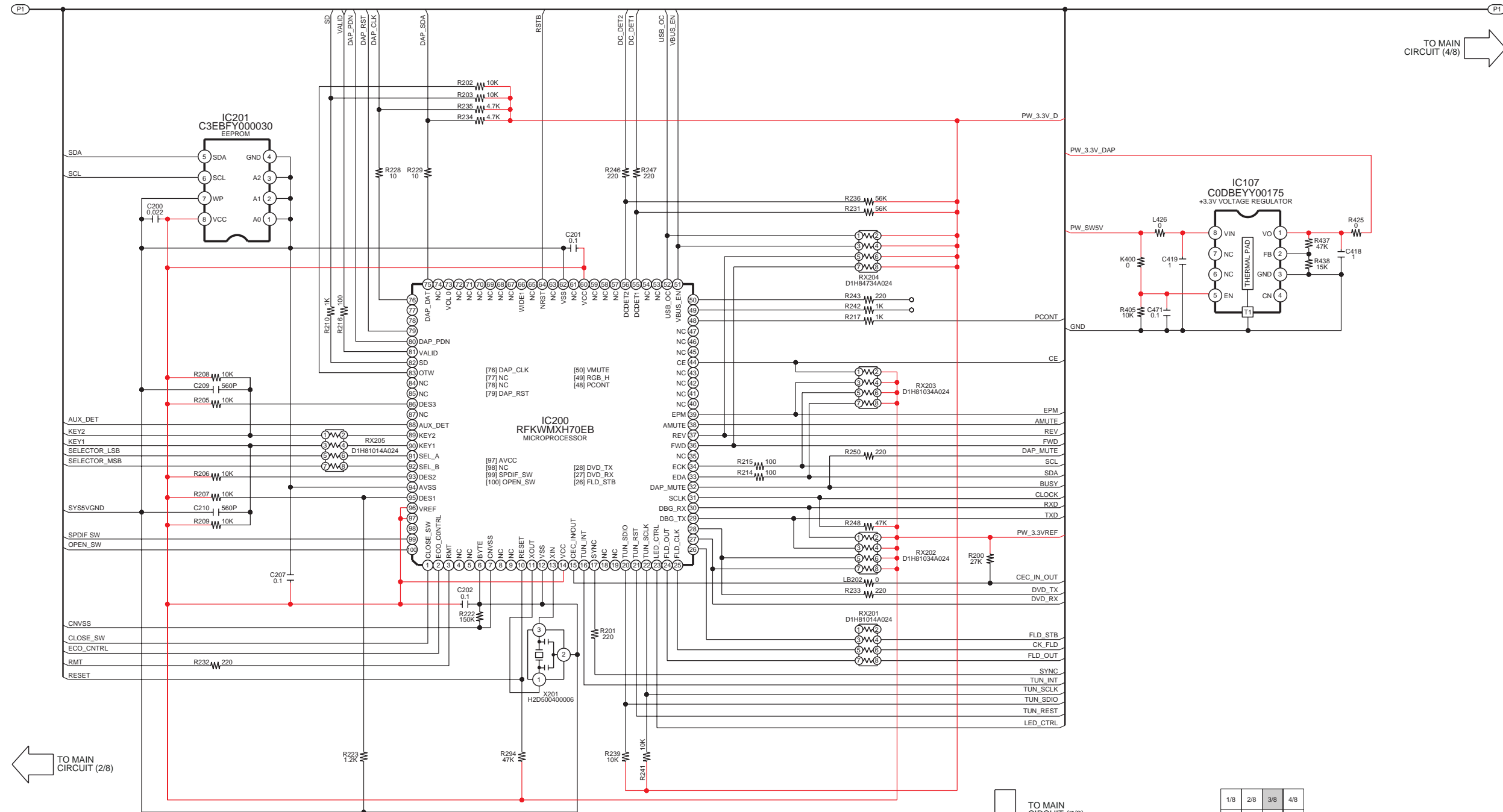

← TO MAIN CIRCUIT (2/8)

↓ TO MAIN CIRCUIT (7/8)

→ TO MAIN CIRCUIT (4/8)

1/8	2/8	3/8	4/8
5/8	6/8	7/8	8/8

SA-XH20PH MAIN CIRCUIT

B MAIN CIRCUIT

— : +B SIGNAL LINE — : -B SIGNAL LINE □ : AUX/TUNER AUDIO INPUT SIGNAL LINE □ : AUDIO OUTPUT SIGNAL LINE □ : FM SIGNAL LINE

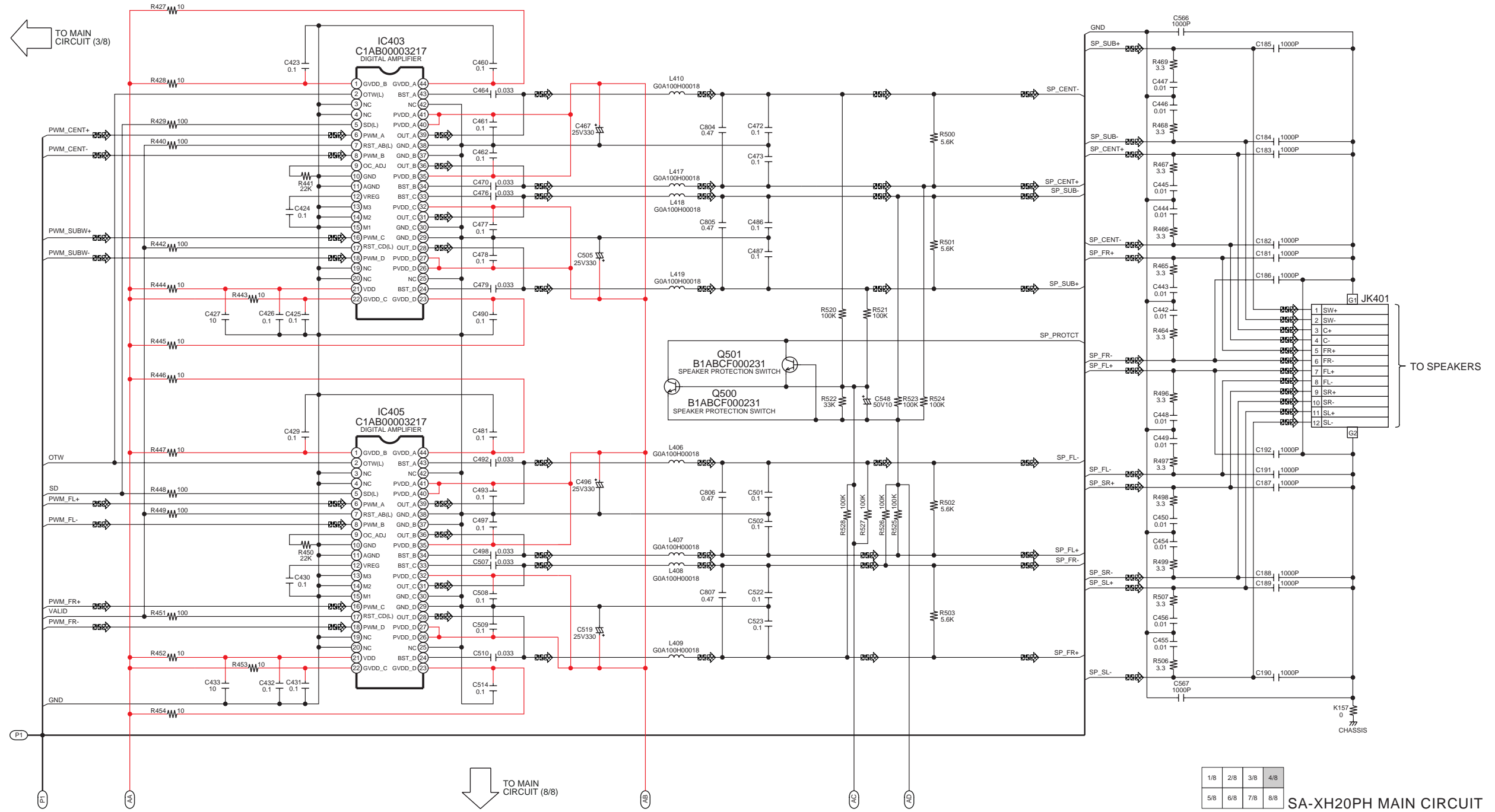

1/8	2/8	3/8	4/8
5/8	6/8	7/8	8/8

SA-XH20PH MAIN CIRCUIT

SCHEMATIC DIAGRAM - 10

B MAIN CIRCUIT

— : +B SIGNAL LINE - - - : -B SIGNAL LINE  : AUX/TUNER AUDIO INPUT SIGNAL LINE  : AUDIO OUTPUT SIGNAL LINE  : FM SIGNAL LINE

↑ TO MAIN CIRCUIT (1/8)

→ TO MAIN CIRCUIT (6/8)

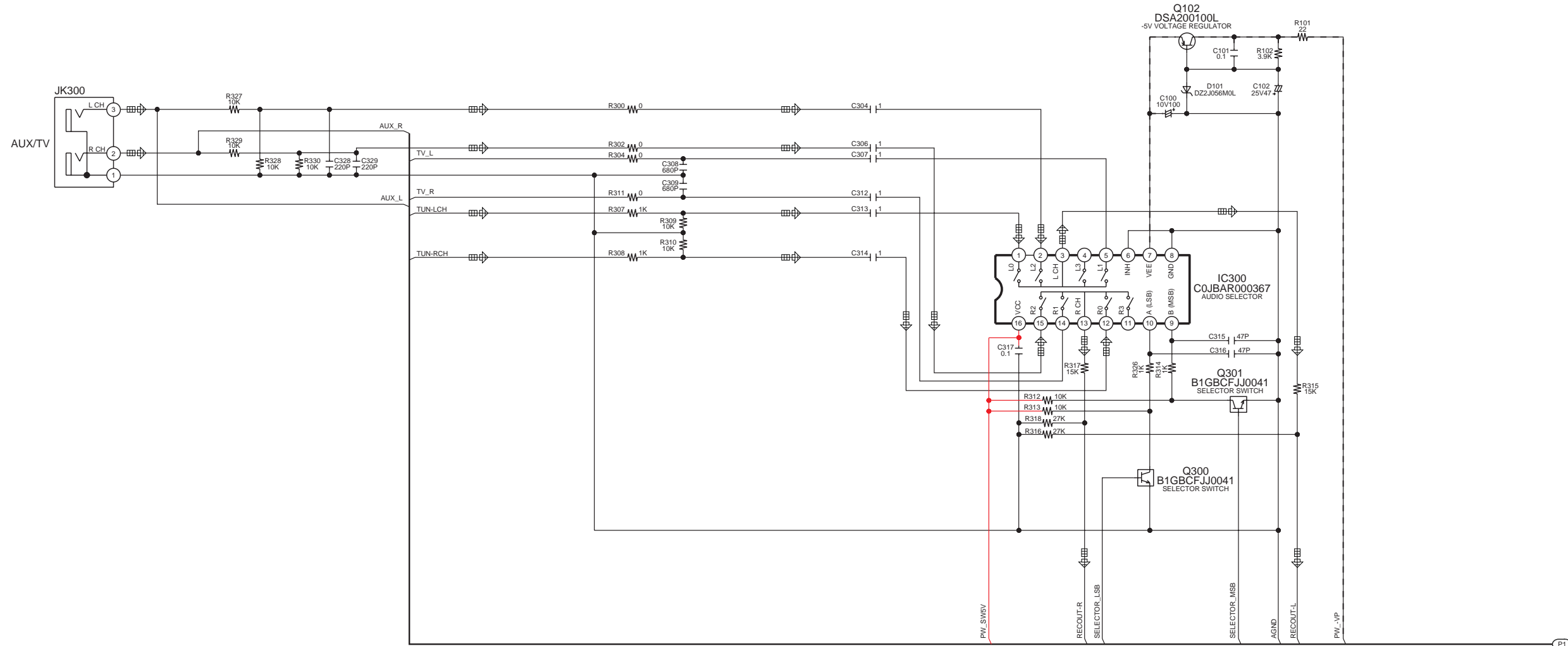

1/8	2/8	3/8	4/8
5/8	6/8	7/8	8/8

SA-XH20PH MAIN CIRCUIT

SCHEMATIC DIAGRAM - 11
B MAIN CIRCUIT

— : +B SIGNAL LINE - - - : -B SIGNAL LINE  : AUX/TUNER AUDIO INPUT SIGNAL LINE  : AUDIO OUTPUT SIGNAL LINE  : FM SIGNAL LINE

← TO MAIN CIRCUIT (5/8)

↑ TO MAIN CIRCUIT (2/8)

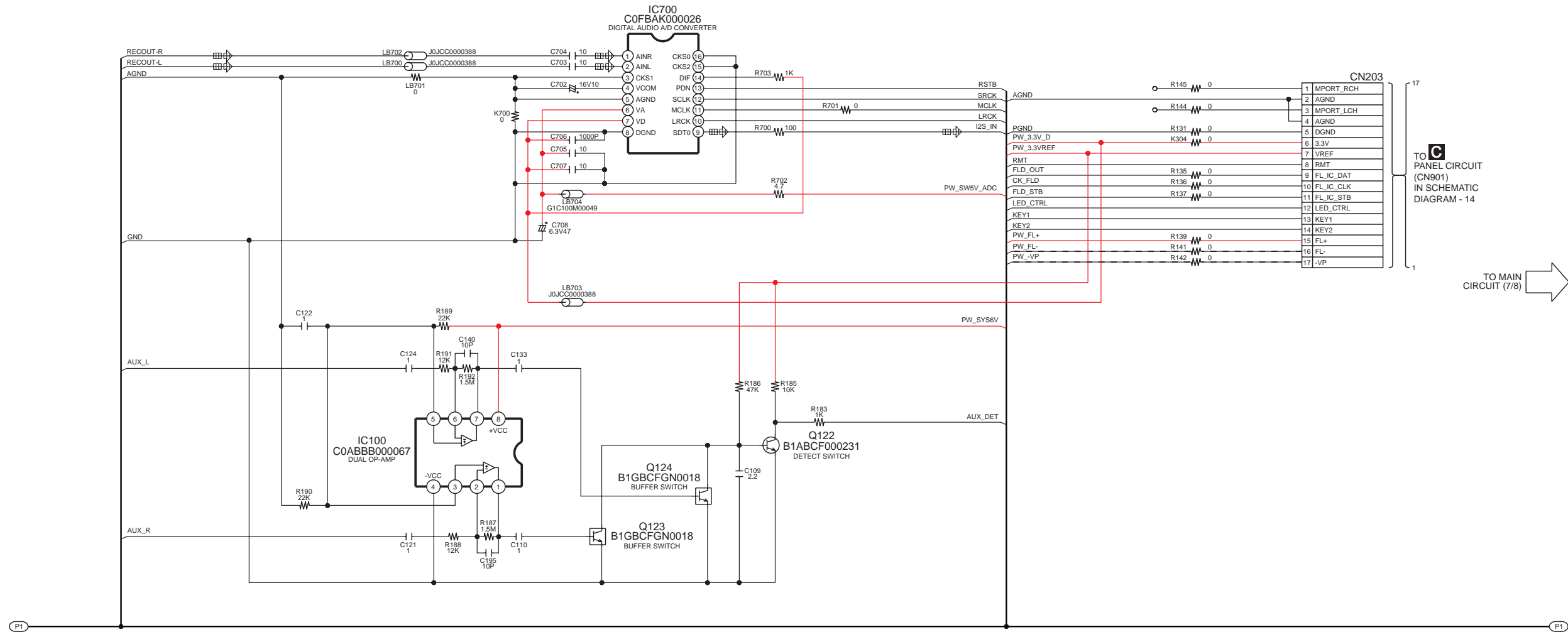

TO **C** PANEL CIRCUIT (CN901) IN SCHEMATIC DIAGRAM - 14

→ TO MAIN CIRCUIT (7/8)

SCHEMATIC DIAGRAM - 12

B MAIN CIRCUIT

—+ : +B SIGNAL LINE —- : -B SIGNAL LINE : AUX/TUNER AUDIO INPUT SIGNAL LINE : AUDIO OUTPUT SIGNAL LINE : FM SIGNAL LINE

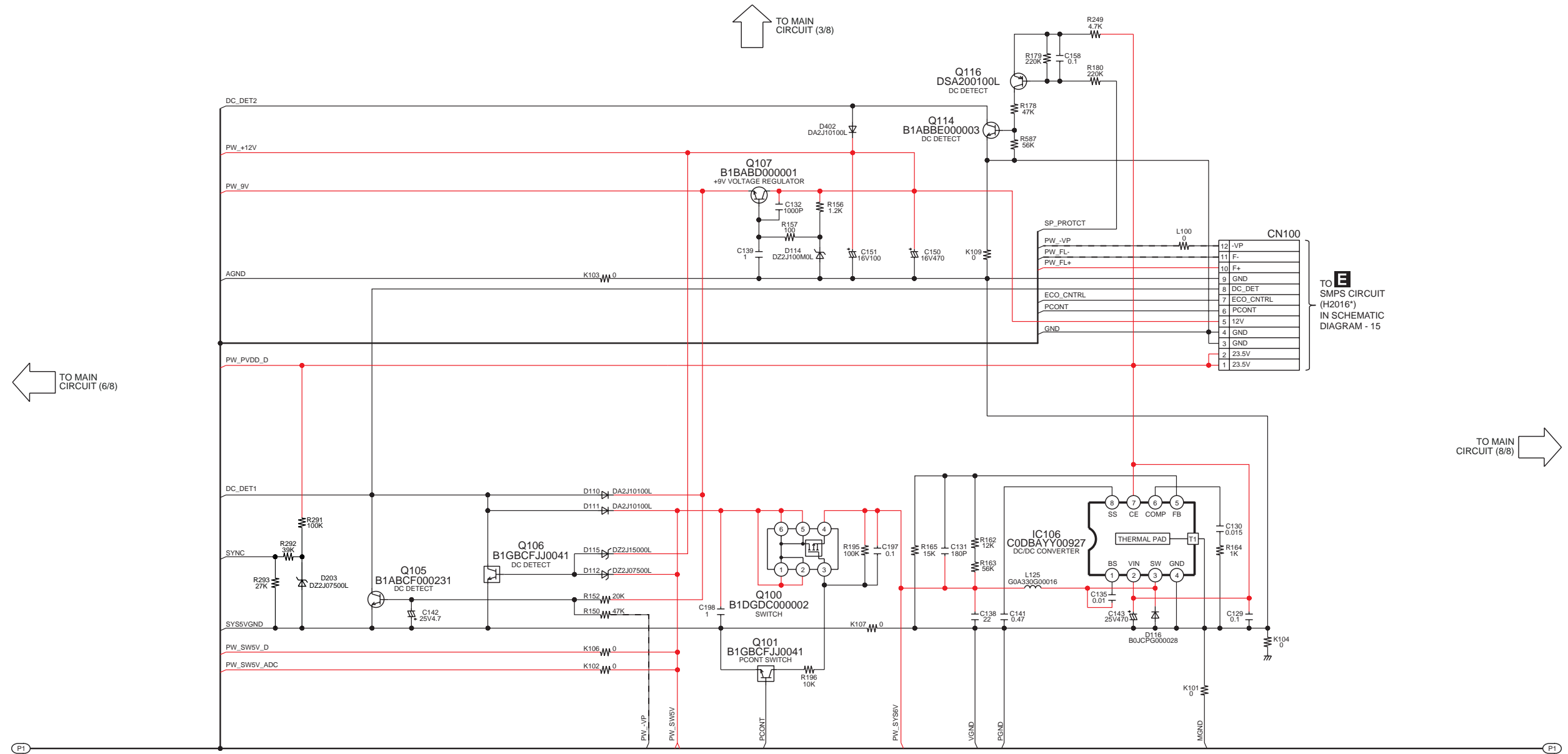

← TO MAIN CIRCUIT (6/8)

↑ TO MAIN CIRCUIT (3/8)

→ TO MAIN CIRCUIT (8/8)

TO **E** SMPS CIRCUIT (H2016*) IN SCHEMATIC DIAGRAM - 15

1/8	2/8	3/8	4/8
5/8	6/8	7/8	8/8

SA-XH20PH MAIN CIRCUIT

SCHEMATIC DIAGRAM - 13

B MAIN CIRCUIT

— : +B SIGNAL LINE - - - : -B SIGNAL LINE  : AUX/TUNER AUDIO INPUT SIGNAL LINE  : AUDIO OUTPUT SIGNAL LINE  : FM SIGNAL LINE

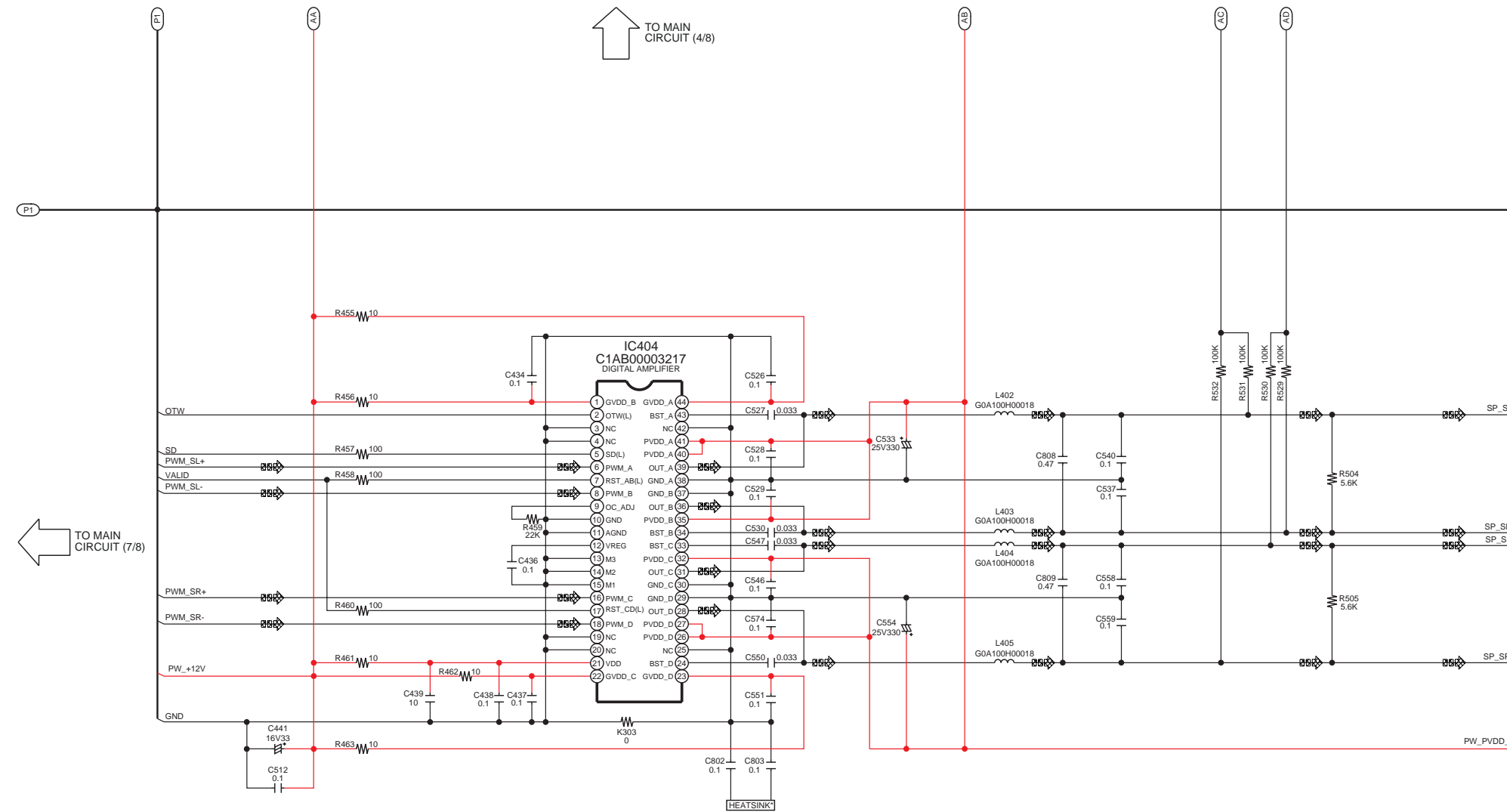

NOTE: " * " REF IS FOR INDICATION ONLY

1/8	2/8	3/8	4/8
5/8	6/8	7/8	8/8

SA-XH20PH MAIN CIRCUIT

43 44 45 46 47 48 49 50 51 52 53 54 55 56

17.4. Panel and Power Button Circuit

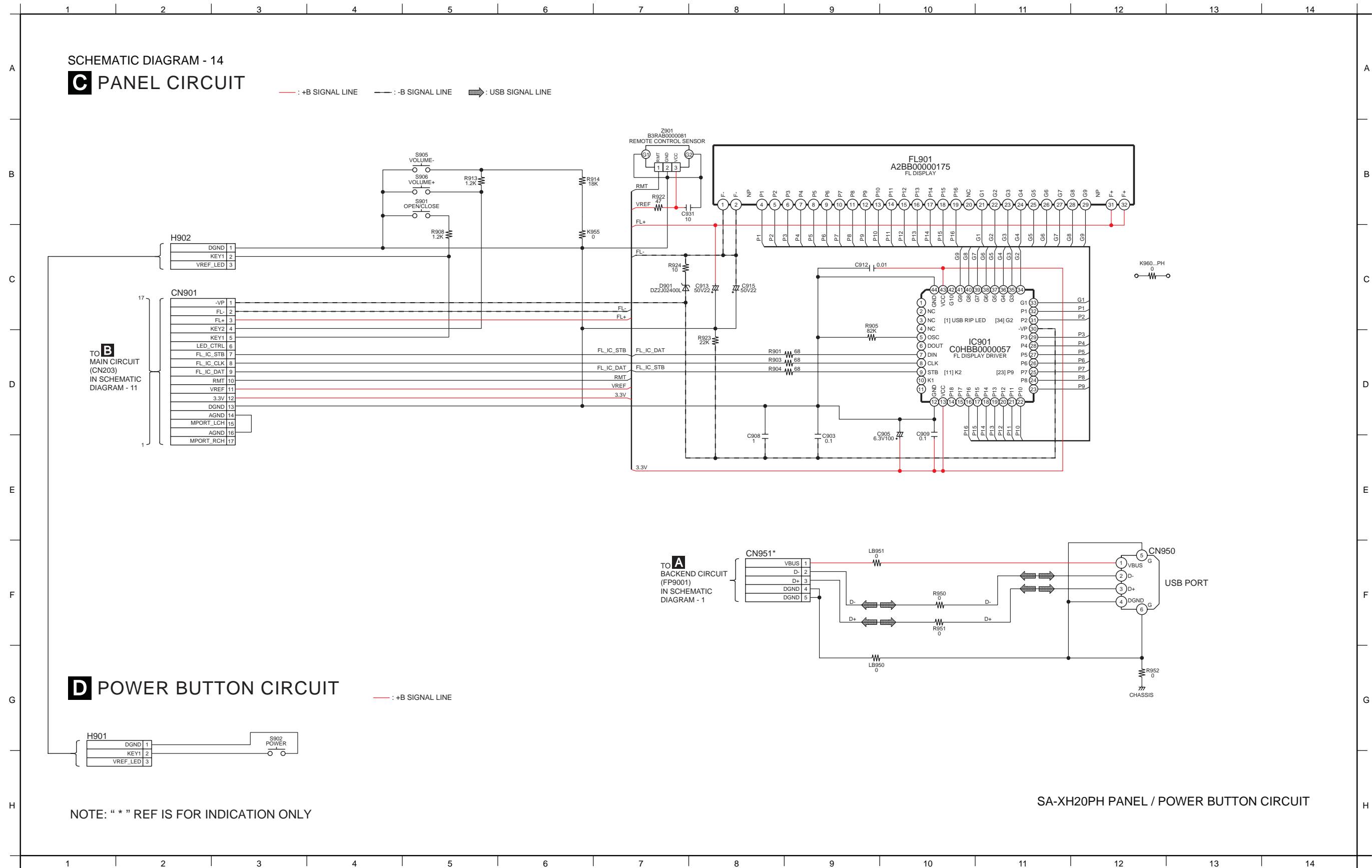

17.5. SMPS Circuit

SCHMATIC DIAGRAM - 15
E SMPS CIRCUIT

— : +B SIGNAL LINE — : -B SIGNAL LINE

TO **B**
 MAIN CIRCUIT
 (CN100)
 IN SCHEMATIC
 DIAGRAM - 12

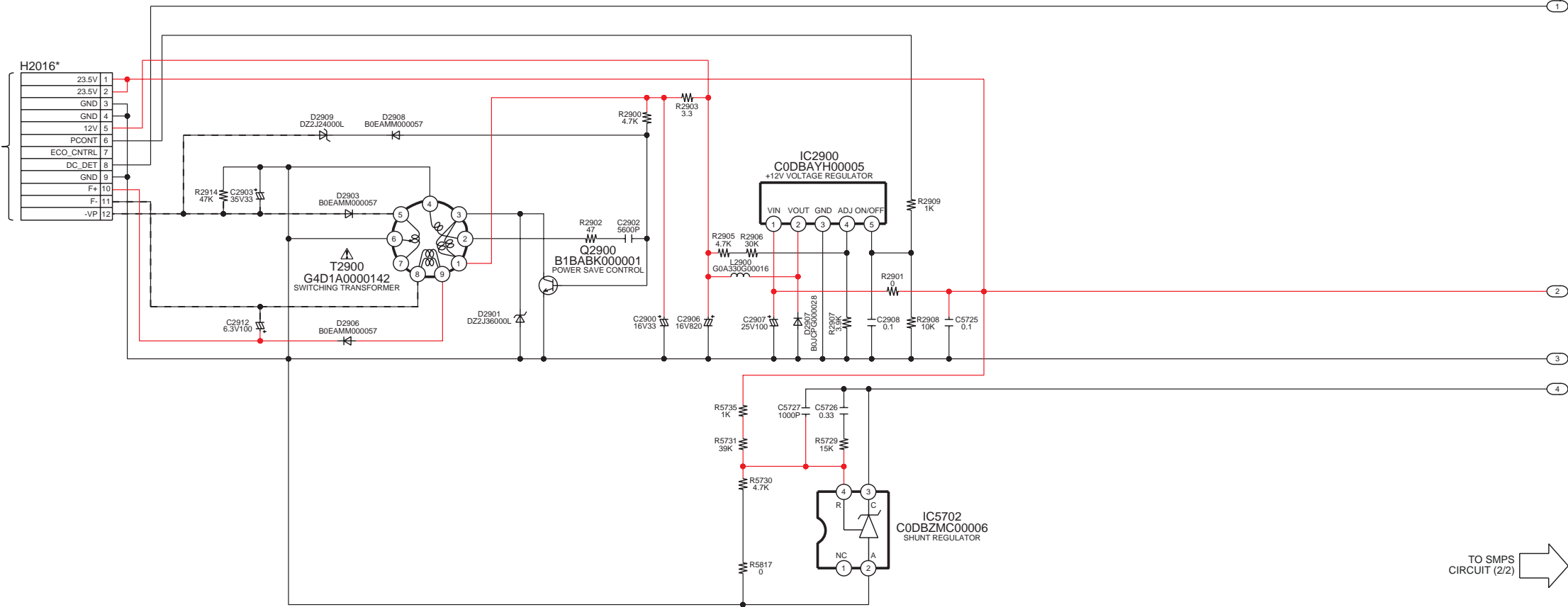

TO SMPS
 CIRCUIT (2/2) →

NOTE: "*" REF IS FOR INDICATION ONLY

1/2 2/2 SA-XH20PH SMPS CIRCUIT

17.6. Component Video Circuit

SCHMATIC DIAGRAM - 17

F COMPONENT VIDEO CIRCUIT

VIDEO OUTPUT SIGNAL LINE

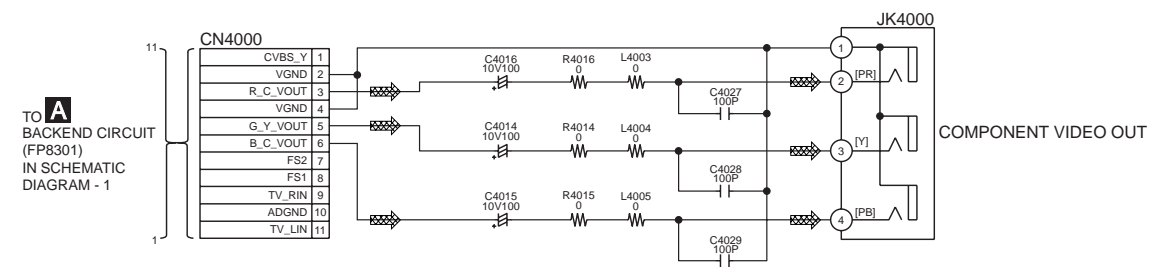

SA-XH20PH COMPONENT VIDEO CIRCUIT

18.2. Main P.C.B.

B MAIN P.C.B. (REP4756ET)

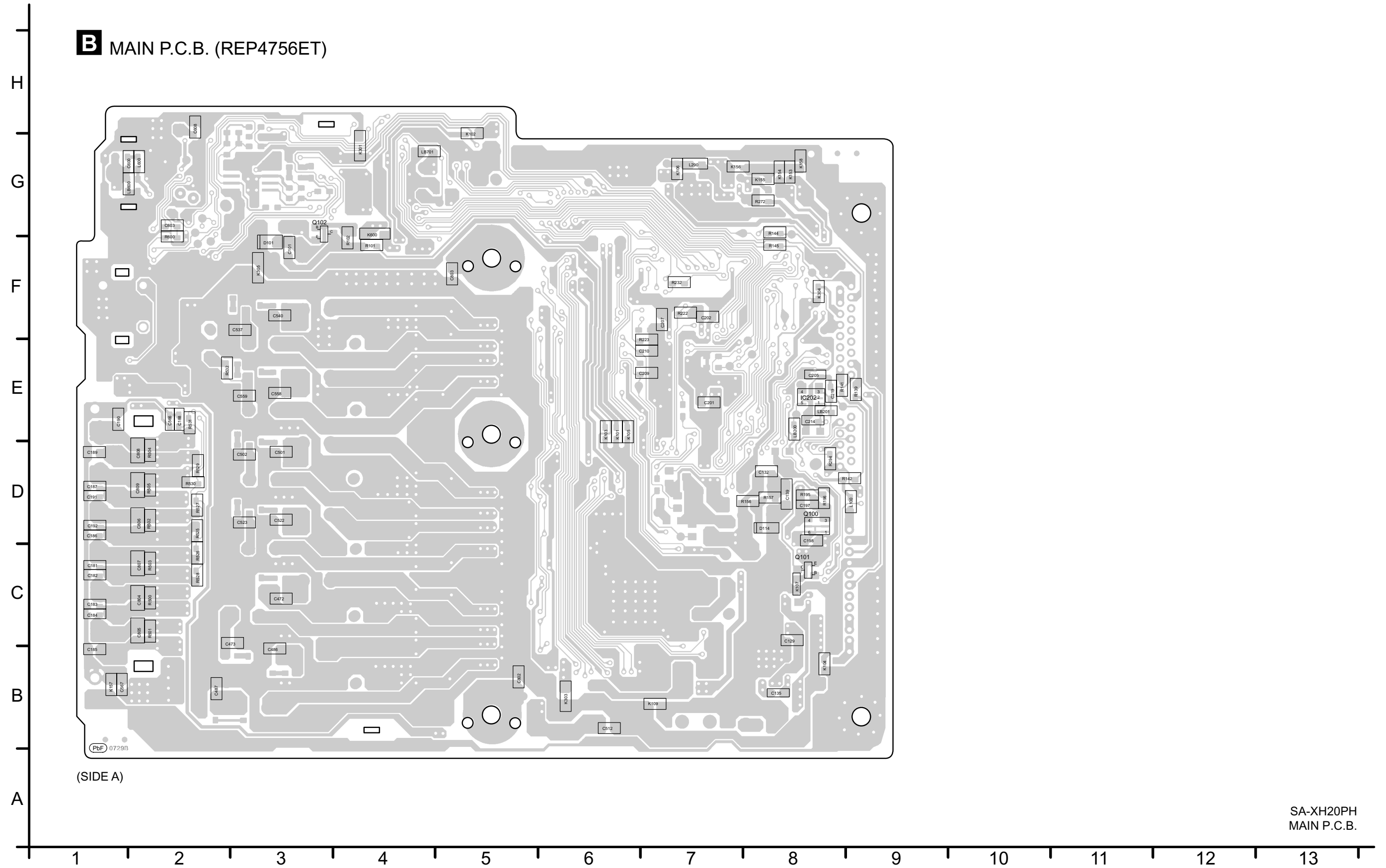

SA-XH20PH
MAIN P.C.B.

18.3. Panel, Power Button and Component Video P.C.B.

H
G
F
E
D
C
B
A

C PANEL P.C.B. (REP4765A)

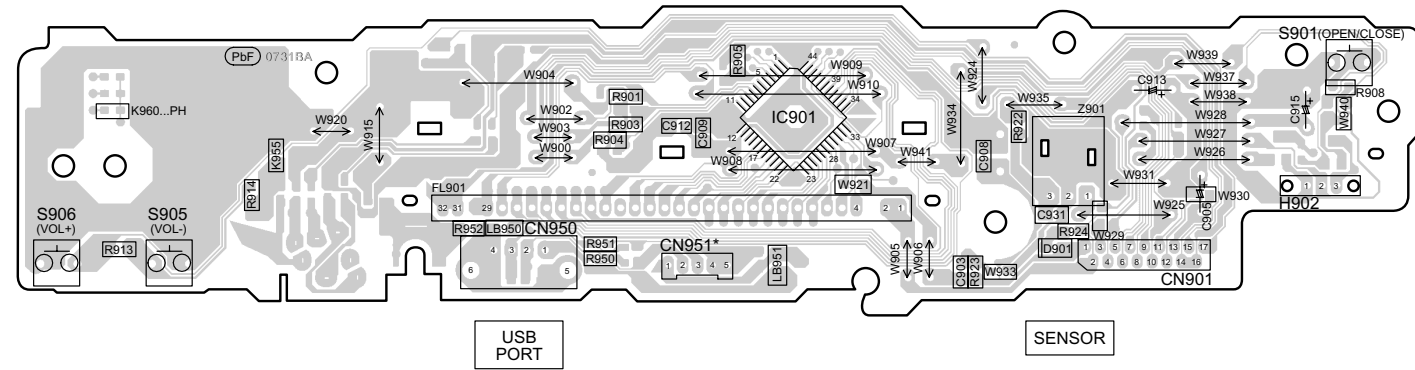

D POWER BUTTON P.C.B. (REP4765A)

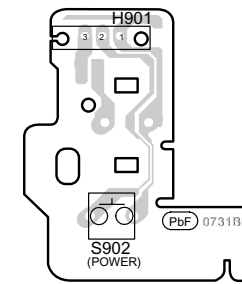

F COMPONENT VIDEO P.C.B. (REP4767A)

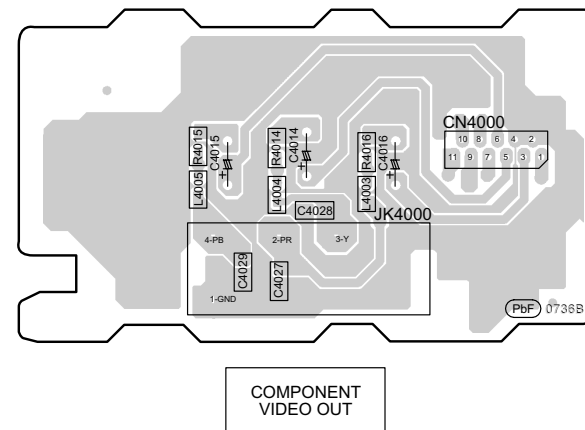

NOTE: "*" REF IS FOR INDICATION ONLY.

SA-XH20PH
PANEL / POWER BUTTON / COMPONENT VIDEO P.C.B.

1 2 3 4 5 6 7 8 9 10 11 12 13

18.4. SMPS P.C.B.

E SMPS P.C.B. (REP4764C)

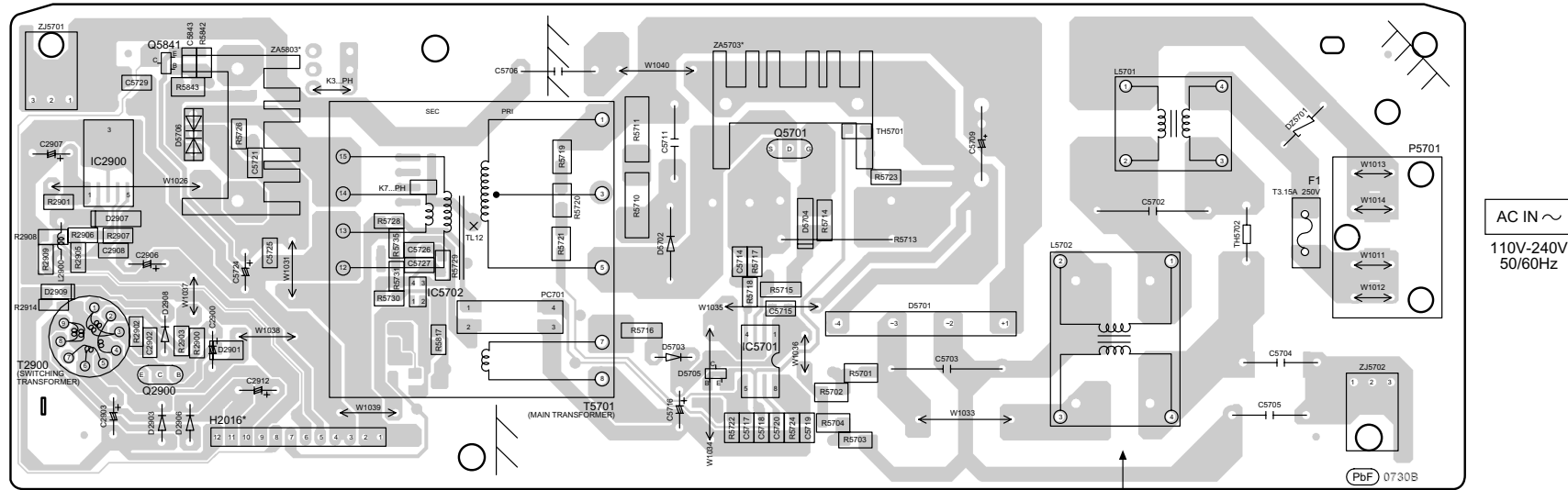

AC IN ~
110V-240V
50/60Hz

CAUTION
RISK OF ELECTRIC SHOCK
AC VOLTAGE LINE.
PLEASE DO NOT TOUCH THIS P.C.B

NOTE: "*" REF IS FOR INDICATION ONLY.

SA-XH20PH
SMPS P.C.B.

19 Appendix Information of Schematic Diagram

19.1. Voltage & Waveform Chart

Note:

- Indication Voltage Values are in standard values for the unit measured by the DC electronic circuit tester (high-impedance) with the chassis taken as standard.
Therefore, there may exist some errors in voltage values, depending on the internal impedance of the DC circuit tester.
- Circuit voltage and waveform described herein shall be regarded as reference information when probing defect point because it may differ from actual measuring value due to difference of Measuring instrument and its measuring condition and product itself.

19.1.1. Backend P.C.B. (1/2)

REF NO.	IC3954																			
MODE	1	2	3	4	5	6	7	8												
HDMI	3.3	3.3	0	0	3.3	1.5	0	3.3												
STANDBY	3.3	3.3	0	0	3.3	1.5	0	3.3												
REF NO.	IC8001																			
MODE	1	2	3	4	5	6	7	8	9	10	11	12	13	14	15	16	17	18	19	20
HDMI	1.0	3.0	0	0	0	0	3.0	0	3.0	3.1	3.1	3.1	2.7	0	0.3	3.1	0.6	0	1.1	0.4
STANDBY	0.9	3.0	0	0	0	0	3.0	0	2.9	3.0	3.0	3.0	2.8	0	0.2	3.3	1.9	0	0.6	1.6
REF NO.	IC8001																			
MODE	21	22	23	24	25	26	27	28	29	30	31	32	33	34	35	36	37	38	39	40
HDMI	1.1	1.0	0.5	1.1	1.1	0.6	3.0	0.7	1.1	0.1	1.1	0.6	0.6	1.7	3.0	3.3	1.5	1.5	0	3.0
STANDBY	1.5	3.1	2.8	1.6	0.3	2.8	3.3	0.6	0.4	0.5	0.5	0	2.6	1.8	3.2	3.3	1.5	1.5	0	3.0
REF NO.	IC8001																			
MODE	41	42	43	44	45	46	47	48	49	50	51	52	53	54	55	56	57	58	59	60
HDMI	3.0	3.0	1.4	1.5	3.0	3.0	3.0	2.9	0	0	3.3	3.3	3.3	3.3	3.3	3.0	3.0	0.9	1.7	1.7
STANDBY	3.0	3.0	1.5	1.5	3.1	3.0	3.1	3.0	0	0	3.3	3.3	3.3	3.3	3.3	3.0	3.1	0.9	1.7	1.7
REF NO.	IC8001																			
MODE	61	62	63	64	65	66	67	68	69	70	71	72	73	74	75	76	77	78	79	80
HDMI	3.3	3.0	3.3	0	3.0	3.0	0	1.6	1.6	3.0	2.0	2.0	3.0	2.0	1.9	1.7	2.0	1.8	2.0	0
STANDBY	3.3	3.1	3.3	0	3.0	3.0	0	0	0	3.1	2.0	1.9	3.1	1.9	2.0	1.3	1.9	1.3	2.0	0
REF NO.	IC8001																			
MODE	81	82	83	84	85	86	87	88	89	90	91	92	93	94	95	96	97	98	99	100
HDMI	1.9	1.5	0.9	3.0	0	0.2	3.0	2.2	0	1.6	3.2	1.7	1.6	2.5	1.7	0	3.2	0	3.0	3.1
STANDBY	1.9	1.6	0.9	3.1	0	0	3.1	3.1	0	0	3.1	1.7	0	0	0	0	0	3.1	3.1	3.1
REF NO.	IC8001																			
MODE	101	102	103	104	105	106	107	108	109	110	111	112	113	114	115	116	117	118	119	120
HDMI	3.0	1.2	0	1.6	2.1	1.3	2.6	3.2	0.6	3.0	1.6	1.6	0	1.8	1.8	3.2	0.8	1.2	1.3	1.8
STANDBY	3.1	1.3	0	1.6	3.1	3.1	3.1	3.1	0	3.1	1.5	1.5	0	1.8	1.7	3.1	0.7	1.2	1.2	1.8
REF NO.	IC8001																			
MODE	121	122	123	124	125	126	127	128												
HDMI	1.7	1.7	1.7	1.2	1.6	1.3	1.6	0												
STANDBY	1.6	1.6	1.6	0.9	1.6	1.6	1.5	0												
REF NO.	IC8051																			
MODE	1	2	3	4	5	6	7	8	9	10	11	12	13	14	15	16	17	18	19	20
HDMI	3.3	1.5	3.3	1.0	1.0	0	0.7	1.2	3.3	0.7	0.7	0	0.7	3.3	2.9	3.3	3.3	3.3	3.3	0
STANDBY	3.3	1.7	3.3	0.3	0.4	0	1.6	0.8	3.3	1.9	1.0	0	0.1	3.3	2.9	3.3	3.3	3.3	3.3	0
REF NO.	IC8051																			
MODE	21	22	23	24	25	26	27	28	29	30	31	32	33	34	35	36	37	38	39	40
HDMI	3.3	0	1.2	1.7	1.2	1.6	3.3	0	1.6	1.6	1.7	1.7	0	0	0	0	3.3	0.3	2.9	0
STANDBY	3.3	0	0	1.7	1.3	1.9	3.3	0	0	1.8	1.7	1.7	0	0	0	0	3.3	0.3	2.9	0

SA-XH20PH BACKEND P.C.B.

19.1.2. Backend P.C.B. (2/2)

REF NO.	IC8051																			
MODE	41	42	43	44	45	46	47	48	49	50	51	52	53	54						
HDMI	0	0.8	3.3	1.0	1.0	0	0.7	1.2	3.3	0.7	0.7	0	0.8	0						
STANDBY	0	1.2	3.3	0.4	0.8	0	1.6	0.2	3.3	1.3	0.3	0	0.7	0						
REF NO.	IC8111																			
MODE	1	2	3	4	5															
POWER ON	3.4	3.4	0	1.9	0.8															
STANDBY	3.5	3.5	0	1.9	0.8															
REF NO.	IC8112																			
MODE	1	2	3	4	5	6	7	8												
POWER ON	3.1	0.8	0	0	4.7	0	0	4.7												
STANDBY	3.1	0.8	0	0	4.7	0	0	4.8												
REF NO.	IC8251																			
MODE	1	2	3	4	5	6	7	8	9	10	11	12	13	14	15	16	17	18	19	20
POWER ON	1.6	0	0	1.6	0	3.1	3.1	8.9	0	0	4.5	4.5	2.4	2.5	2.5	2.5	3.4	1.6	4.8	0
STANDBY	1.3	0	0	1.3	0	3.2	3.2	9.2	0	0	2.0	0	1.4	1.4	1.4	1.4	1.3	1.3	4.9	0
REF NO.	IC8251																			
MODE	21	22	23	24	25	26	27	28												
POWER ON	1.4	0	1.9	0	0	1.6	1.6	3.1												
STANDBY	1.5	0	1.1	0	0	1.3	1.6	0												
REF NO.	IC8606																			
MODE	1	2	3	4	5															
HDMI	0	0	0	3.1	3.3															
STANDBY	0	0	0	3.3	3.3															
REF NO.	IC8651																			
MODE	1	2	3	4	5	6	7	8												
HDMI	2.2	2.7	3.3	0	1.2	0.6	3.3	3.3												
STANDBY	2.9	3.1	3.3	0	1.1	0.2	3.3	3.3												
REF NO.	IC9006																			
MODE	1	2	3	4	5															
CD PLAY	5.0	0	3.3	3.3	5.0															
STANDBY	5.0	0	3.3	3.3	5.1															
REF NO.	Q8552																			
MODE	E	C	B																	
HDMI	3.1	2.3	2.4																	
STANDBY	3.3	0	3.3																	
REF NO.	Q8562			Q8565																
MODE	E	C	B		E	C	B													
CD PLAY	3.3	3.3	3.3		0	0	0.7													
STANDBY	3.3	3.3	3.3		0	4.8	0													

SA-XH20PH BACKEND P.C.B.

19.1.3. Main P.C.B. (1/3)

REF NO.	IC100																			
MODE	1	2	3	4	5	6	7	8												
POWER ON	3.1	3.1	3.1	0	3.1	3.1	3.1	5.1												
STANDBY	0	0	0	0	0	0	0	5.1												
REF NO.	IC106																			
MODE	1	2	3	4	5	6	7	8												
POWER ON	9.6	20.5	4.4	0	0.9	1.3	20.6	0.9												
STANDBY	9.6	20.5	4.4	0	0.9	1.3	20.6	0.9												
REF NO.	IC107																			
MODE	1	2	3	4	5	6	7	8												
POWER ON	3.0	0.8	0	0	4.7	0	0	4.7												
STANDBY	3.0	0.8	0	0	4.7	0	0	4.7												
REF NO.	IC200																			
MODE	1	2	3	4	5	6	7	8	9	10	11	12	13	14	15	16	17	18	19	20
POWER ON	3.3	3.3	3.2	0	0	0	0	0	0	0	1.6	0	1.4	3.2	3.2	3.2	3.2	0	0	3.2
STANDBY	3.3	3.3	3.2	0	0	0	0	0	0	0	1.6	0	1.4	3.2	3.2	3.2	3.2	0	0	3.2
REF NO.	IC200																			
MODE	21	22	23	24	25	26	27	28	29	30	31	32	33	34	35	36	37	38	39	40
POWER ON	3.2	3.2	3.2	1.3	2.6	1.9	3.0	3.1	0	0	0	3.2	0	0	0	3.2	3.2	0	0	0
STANDBY	3.2	3.2	3.2	1.3	2.6	1.9	3.0	3.1	0	0	0	3.2	0	0	0	3.2	3.2	0	0	0
REF NO.	IC200																			
MODE	41	42	43	44	45	46	47	48	49	50	51	52	53	54	55	56	57	58	59	60
POWER ON	0	0	0	3.3	0	0	0	3.2	0	0	3.3	3.3	0	0	3.3	3.3	0	0	0	3.3
STANDBY	0	0	0	3.3	0	0	0	3.2	0	0	3.3	3.3	0	0	3.3	3.3	0	0	0	3.3
REF NO.	IC200																			
MODE	61	62	63	64	65	66	67	68	69	70	71	72	73	74	75	76	77	78	79	80
POWER ON	0	0	1.3	3.2	0	3.3	0	1.3	1.3	0	3.2	0	3.2	0	3.3	3.2	0	0	3.2	3.2
STANDBY	0	0	1.3	3.2	0	3.3	0	1.3	1.3	0	3.2	0	3.2	0	3.3	3.2	0	0	3.2	3.2
REF NO.	IC200																			
MODE	81	82	83	84	85	86	87	88	89	90	91	92	93	94	95	96	97	98	99	100
POWER ON	3.2	3.2	3.2	0	0	0	0	1.3	2.1	3.2	3.2	3.2	0.4	0	0.8	3.2	3.3	0	3.2	3.2
STANDBY	3.2	3.2	3.2	0	0	0	0	1.3	2.1	3.2	3.2	3.2	0.4	0	0.8	3.2	3.3	0	3.2	3.2
REF NO.	IC201																			
MODE	1	2	3	4	5	6	7	8												
POWER ON	0	0	0	0	3.0	3.3	0	3.2												
STANDBY	0	0	0	0	3.0	3.3	0	3.2												
REF NO.	IC202																			
MODE	1	2	3	4	5															
POWER ON	5.0	0	6.0	0	3.3															
STANDBY	5.0	0	6.0	0	3.3															

SA-XH20PH MAIN P.C.B.

19.1.4. Main P.C.B. (2/3)

REF NO.	IC300																			
MODE	1	2	3	4	5	6	7	8	9	10	11	12	13	14	15	16				
SELECTOR	2.8	3.0	2.2	3.0	3.0	0	-5.0	0	3.0	3.0	3.0	2.8	2.2	3.0	3.0	5.0				
STANDBY	2.8	3.0	0	3.0	3.0	0	-5.0	0	3.0	3.0	3.0	2.8	0	3.0	3.0	5.0				
REF NO.	IC401																			
MODE	1	2	3	4	5	6	7	8	9	10	11	12	13	14	15	16	17	18	19	20
CD PLAY	1.8	0	0.8	0.9	0	0	2.0	0	3.3	1.3	3.3	0	3.3	3.3	3.3	0	1.9	0	0.5	0.8
STANDBY	1.8	0	0.8	0.9	0	0	1.9	0	3.3	1.3	3.3	0	3.3	3.3	3.3	0	1.9	0	0	0.9
REF NO.	IC401																			
MODE	21	22	23	24	25	26	27	28	29	30	31	32	33	34	35	36	37	38	39	40
CD PLAY	0	0	0	3.3	3.3	1.7	0	3.3	3.3	3.3	3.3	3.3	0	0	0	3.3	0	0	0	3.0
STANDBY	0	0	0	0	3.3	1.7	0	0	3.3	0	0	3.3	0	0	0	3.3	0	0	0	0
REF NO.	IC401																			
MODE	41	42	43	44	45	46	47	48	49	50	51	52	53	54	55	56	57	58	59	60
CD PLAY	1.4	1.3	1.3	1.2	1.2	1.2	1.2	0	1.1	1.1	1.4	1.4	0	3.3	0	0	0	0	0	0
STANDBY	0	0	0	0	0	0	0	0	0	0	0	0	0	3.3	0	0	0	0	0	0
REF NO.	IC401																			
MODE	61	62	63	64																
CD PLAY	0	0	0	0																
STANDBY	0	0	0	0																
REF NO.	IC403																			
MODE	1	2	3	4	5	6	7	8	9	10	11	12	13	14	15	16	17	18	19	20
CD PLAY	12.0	3.3	0	0	3.2	1.6	3.3	1.4	0	0	0	0	0	0	0	1.4	3.9	1.4	0	0
STANDBY	12.0	3.3	0	0	0	0	3.3	0	0	0	0	0	0	0	0	0	0	0	0	0
REF NO.	IC403																			
MODE	21	22	23	24	25	26	27	28	29	30	31	32	33	34	35	36	37	38	39	40
CD PLAY	12.0	12.0	12.0	10.1	0	20.3	20.3	1.4	0	0	1.4	20.3	10.2	10.2	20.3	1.2	0	0	1.2	20.3
STANDBY	12.0	12.0	12.0	10.1	0	20.3	20.3	0	0	0	0	20.3	10.2	10.2	20.3	0	0	0	0	20.3
REF NO.	IC403																			
MODE	41	42	43	44																
CD PLAY	20.3	0	10.2	12.0																
STANDBY	20.3	0	10.2	12.0																
REF NO.	IC404																			
MODE	1	2	3	4	5	6	7	8	9	10	11	12	13	14	15	16	17	18	19	20
CD PLAY	12.0	3.3	0	0	3.2	1.6	3.3	1.4	0	0	0	0	0	0	0	1.4	3.9	1.4	0	0
STANDBY	12.0	3.3	0	0	0	0	3.3	0	0	0	0	0	0	0	0	0	0	0	0	0
REF NO.	IC404																			
MODE	21	22	23	24	25	26	27	28	29	30	31	32	33	34	35	36	37	38	39	40
CD PLAY	12.0	12.0	12.0	10.1	0	20.3	20.3	1.4	0	0	1.4	20.3	10.2	10.2	20.3	1.2	0	0	1.2	20.3
STANDBY	12.0	12.0	12.0	10.1	0	20.3	20.3	0	0	0	0	20.3	10.2	10.2	20.3	0	0	0	0	20.3

SA-XH20PH MAIN P.C.B.

19.1.5. Main P.C.B. (3/3)

REF NO.	IC404																			
MODE	41	42	43	44																
CD PLAY	20.3	0	10.2	12.0																
STANDBY	20.3	0	10.2	12.0																
REF NO.	IC405																			
MODE	1	2	3	4	5	6	7	8	9	10	11	12	13	14	15	16	17	18	19	20
CD PLAY	12.0	3.3	0	0	3.2	1.6	3.3	1.4	0	0	0	0	0	0	0	1.4	3.9	1.4	0	0
STANDBY	12.0	3.3	0	0	0	0	3.3	0	0	0	0	0	0	0	0	0	0	0	0	0
REF NO.	IC405																			
MODE	21	22	23	24	25	26	27	28	29	30	31	32	33	34	35	36	37	38	39	40
CD PLAY	12.0	12.0	12.0	10.1	0	20.3	20.3	1.4	0	0	1.4	20.3	10.2	10.2	20.3	1.2	0	0	1.2	20.3
STANDBY	12.0	12.0	12.0	10.1	0	20.3	20.3	0	0	0	0	20.3	10.2	10.2	20.3	0	0	0	0	20.3
REF NO.	IC405																			
MODE	41	42	43	44																
CD PLAY	20.3	0	10.2	12.0																
STANDBY	20.3	0	10.2	12.0																
REF NO.	IC600																			
MODE	1	2	3	4	5	6	7	8	9	10	11	12	13	14	15	16	17	18	19	20
TUNER	0	2.8	0	0	2.8	0	3.3	2.8	2.8	3.3	3.3	0	2.8	2.8	2.8	0	2.8	0	0	0
STANDBY	0	2.8	0	0	2.8	0	3.3	2.8	2.8	3.3	3.3	0	2.8	2.8	2.8	0	2.8	0	0	0
REF NO.	IC700																			
MODE	1	2	3	4	5	6	7	8	9	10	11	12	13	14	15	16				
CD PLAY	2.4	2.4	0	2.4	0	4.8	3.3	0	1.2	1.4	1.5	1.5	3.1	3.1	0	0				
STANDBY	0	0	0	2.4	0	4.8	3.3	0	0	0	1.5	1.5	3.1	3.1	0	0				
REF NO.	Q100						Q101				Q102				Q105					
MODE	1	2	3	4	5	6	E	C	B	E	C	B	E	C	B	E	C	B		
POWER ON	4.9	4.9	0	5.0	4.9	4.9	0	0	2.7	-5.0	-6.0	0	0	3.2	0					
STANDBY	4.9	4.9	0	5.0	4.9	4.9	0	0	2.7	-5.0	-6.0	0	0	3.2	0					
REF NO.	Q106			Q107			Q114			Q116			Q122							
MODE	E	C	B	E	C	B	E	C	B	E	C	B	E	C	B					
POWER ON	0	3.1	0	9.3	12.1	10.0	0	3.1	0	20.6	0	0	0	3.1	3.1					
STANDBY	0	3.1	0	9.3	12.1	10.0	0	3.1	0	20.6	0	0	0	0	0					
REF NO.	Q123			Q124			Q500			Q501										
MODE	E	C	B	E	C	B	E	C	B	E	C	B								
POWER ON	0	3.1	3.1	0	3.1	3.1	1.4	0	10.3	10.3	0	1.4								
STANDBY	0	0	0	0	0	0	1.4	0	10.3	10.3	0	1.4								
REF NO.	Q300			Q301																
MODE	E	C	B	E	C	B														
SELECTOR	0	7.0	3.1	0	7.0	3.1														
STANDBY	0	7.0	3.1	0	7.0	0														

SA-XH20PH MAIN P.C.B.

19.1.6. Panel P.C.B.

REF NO.	IC901																			
MODE	1	2	3	4	5	6	7	8	9	10	11	12	13	14	15	16	17	18	19	20
POWER ON	0	0	0	0	1.8	0	1.2	2.6	1.8	0	0	0	3.1	-24.9	-24.9	-24.9	-15.6	-15.6	-15.6	-15.6
STANDBY	0	0	0	0	1.8	0	1.2	2.6	1.8	0	0	0	3.1	-24.9	-24.9	-24.9	-15.6	-15.6	-15.6	-15.6

REF NO.	IC901																			
MODE	21	22	23	24	25	26	27	28	29	30	31	32	33	34	35	36	37	38	39	40
POWER ON	-24.9	-24.9	-24.9	-24.9	-24.9	-24.9	-24.9	-13.3	-25.0	-25.5	-11.1	-25.1	-22.9	-22.9	-22.9	-22.9	-22.9	-22.9	-22.9	-22.9
STANDBY	-24.9	-24.9	-24.9	-24.9	-24.9	-24.9	-24.9	-13.3	-25.0	-25.5	-11.1	-25.1	-22.9	-22.9	-22.9	-22.9	-22.9	-22.9	-22.9	-22.9

REF NO.	IC901																			
MODE	41	42	43	44																
POWER ON	-22.9	-22.8	3.3	0																
STANDBY	-22.9	-22.8	3.3	0																

SA-XH20PH PANEL P.C.B.

19.1.7. SMPS P.C.B.

REF NO.	IC2900																			
MODE	1	2	3	4	5															
POWER ON	20.1	12.1	0	1.2	2.5															
STANDBY	20.1	12.1	0	1.2	2.5															











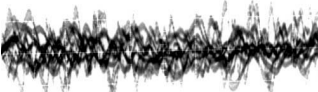

REF NO.	IC5701																			
MODE	1	2	3	4	5	6	7	8												
POWER ON	5.0	0	0.5	1.5	5.0	5.0	1.6	0												
STANDBY	5.0	0	0.5	1.5	5.0	5.0	1.4	0												

REF NO.	IC5702																			
MODE	1	2	3	4																
POWER ON	0	0	22.3	23.5																
STANDBY	0	0	22.3	23.5																

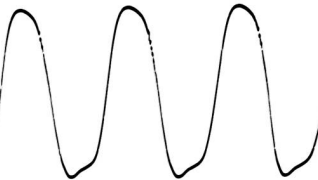

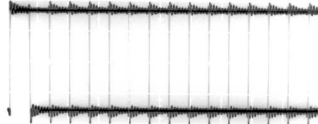
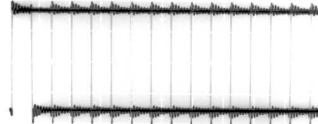
REF NO.	Q2900				Q5701			Q5841												
MODE	E	C	B		S	D	G		E	C	B									
POWER ON	0	11.9	0		0	1.5	0.5		0	3.2	0									
STANDBY	0	11.7	0		0	1.5	0.5		0	3.2	0									

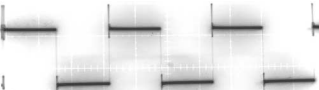
SA-XH20PH SMPS P.C.B.

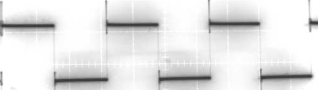
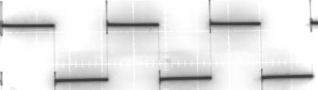
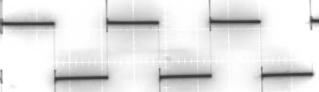
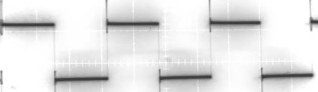
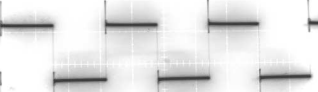
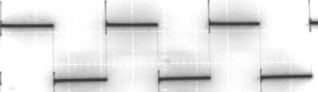
19.1.8. Waveform Table (1/2)

<p>WF No. IC200-11 (PLAY)</p>  <p>1.5Vp-p(50nsec/div)</p>	<p>WF No. IC200-13 (PLAY)</p>  <p>2Vp-p(50nsec/div)</p>	<p>WF No. IC300-1,12 (PLAY)</p>  <p>0.4Vp-p(200usec/div)</p>	<p>WF No. IC300-2 (PLAY)</p>  <p>0.06Vp-p(2usec/div)</p>
<p>WF No. IC300-3 (PLAY)</p>  <p>1.25Vp-p(2usec/div)</p>	<p>WF No. IC300-13 (PLAY)</p>  <p>0.15Vp-p(2usec/div)</p>	<p>WF No. IC300-15 (PLAY)</p>  <p>0.05Vp-p(2usec/div)</p>	<p>WF No. IC401-19 (PLAY)</p>  <p>2Vp-p(20nsec/div)</p>
<p>WF No. IC401-20 (PLAY)</p>  <p>1Vp-p(20nsec/div)</p>	<p>WF No. IC401-28,29 (PLAY)</p>  <p>3.2Vp-p(500nsec/div)</p>	<p>WF No. IC401-30,31 (PLAY)</p>  <p>3.6Vp-p(500nsec/div)</p>	<p>WF No. IC401-40,41 (PLAY)</p>  <p>6Vp-p(1usec/div)</p>
<p>WF No. IC401-42,43,44,45,46,47 (PLAY)</p>  <p>6Vp-p(1usec/div)</p>	<p>WF No. IC401-49,50,51,52 (PLAY)</p>  <p>6Vp-p(500nsec/div)</p>	<p>WF No. IC403-6,8,16,18 (PLAY)</p>  <p>6Vp-p(1usec/div)</p>	<p>WF No. IC403-28,31,36,39 (PLAY)</p>  <p>32Vp-p(1usec/div)</p>
<p>WF No. IC404-6,8,16,18 (PLAY)</p>  <p>6Vp-p(1usec/div)</p>	<p>WF No. IC404-28,31,36,39 (PLAY)</p>  <p>32Vp-p(1usec/div)</p>	<p>WF No. IC405-6,8,16,18 (PLAY)</p>  <p>6Vp-p(1usec/div)</p>	<p>WF No. IC405-28,31,36,39 (PLAY)</p>  <p>32Vp-p(1usec/div)</p>

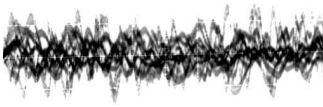
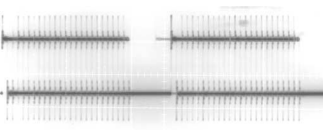
19.1.9. Waveform Table (2/2)

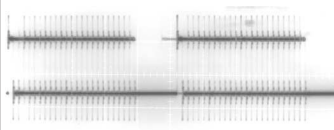
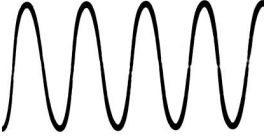
<p>WF No. IC600-2,13,14 (PLAY)</p>  <p>0.4Vp-p(200usec/div)</p>	<p>WF No. IC8001-36,42 (PLAY)</p>  <p>4.8Vp-p(2usec/div)</p>	<p>WF No. IC8001-63 (PLAY)</p>  <p>1.25Vp-p(50usec/div)</p>	<p>WF No. IC8001-102 (PLAY)</p>  <p>5Vp-p(1usec/div)</p>
<p>WF No. IC8001-111,112 (PLAY)</p>  <p>2Vp-p(20nsec/div)</p>			

19.2. Illustration of ICs, Transistor and Diode

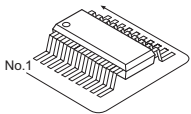
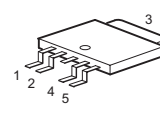
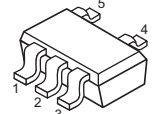
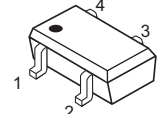
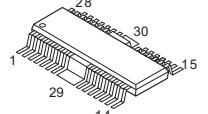
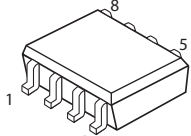
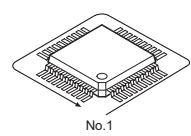
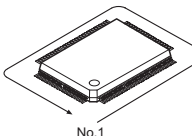
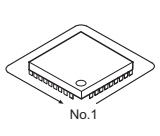
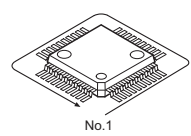
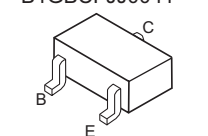
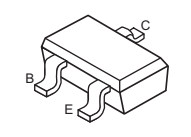
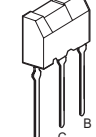
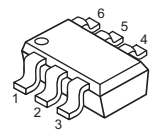
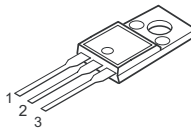
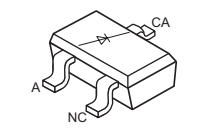
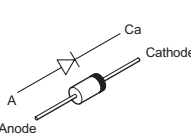
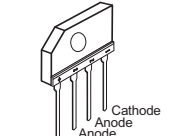
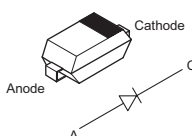
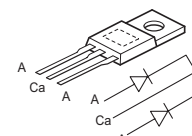
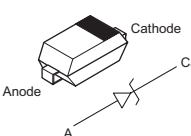
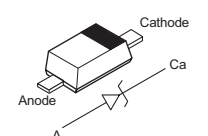
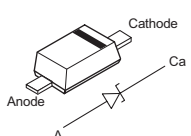
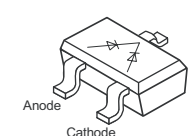
<p>C0ABBB000067 (8P)</p> 	<p>C0DBAYY00927 (8P) C0DBEYY00175 (8P) C0DBZYY00448 (8P) C0FBAK000026 (16P) C0JBAR000367 (16P) C1AB00003217 (44P) C3ABPG000163 (54P) C3EBFY000030 (8P) RFKWFHX170E (8P)</p>	<p>C0DBAYH00005 C0DBEYY00215</p> 	<p>C0DBGYY02930 C0DBZYY00311 C0EBE0000504</p> 	<p>C0DBZMC00006</p> 	<p>C0GBY0000117</p> 
<p>C0JBAR000433</p> 	<p>C0HBB0000057 (44P) C1AB00003610 (64P)</p> 	<p>C1AB00003477 (128P)</p> 	<p>VUEALLPT040</p> 	<p>RFKWMXH70EB (100P)</p> 	<p>B1ABDF000026 B1GBCFGG0025 B1GBCFJJ0041</p> 
<p>B1ABBE000003</p> 	<p>B1ABCF000231 B1GBCFGN0018 DSA200100L DSA200200L</p>	<p>B1BABD000001 B1BABK000001</p> 	<p>B1DGDC000002</p> 	<p>B1KAB0000021</p> 	<p>B0BC02700039</p> 
<p>B0EAKT000063 B0EAMM000057</p> 	<p>B0EBNR000045</p> 	<p>B0ECKP000062</p> 	<p>B0HBSM000054</p> 	<p>B0JCME000035 B0JCPG000028</p> 	<p>DA2J10100L</p> 
<p>DZ2J02400L</p> 	<p>DZ2J056M0L DZ2J07500L DZ2J100M0L DZ2J15000L DZ2J24000L DZ2J36000L</p>	<p>DA3X101F0L DA3X103E0L</p> 			

19.3. Terminal Function of ICs

19.3.1. IC200 (RFKWMXH70EB): IC MICRO-PROCESSOR

Pin No.	Terminal Name	I/O	Function
1	CLOSE_SW	I	Close Switch for Mechanism
2	ECO_CONTRL	O	Control Voltage Supply of D-AMP for Eco Mode
3	RMT	I	Remote Control Signal
4	NC	-	No Connection
5	NC	-	No Connection
6	BYTE	-	External data bus width select input
7	CNVSS	-	Micon Programming-Processor / Single Chip Mode
8	NC	-	No Connection
9	NC	-	No Connection
10	RESET	I	Microp Reset Signal
11	XOUT	O	Clock Out
12	VSS	-	GND
13	XIN	I	Clock In
14	VCC	-	VCC +3.3V
15	CEC_IN/OUT	I/O	CEC in/out
16	TUN_INT	O	Tuner Interrupt
17	SYNC	I	AC Sync Signal
18	NC	-	No Connection
19	NC	-	No Connection
20	TUN_SDIO	O	Tuner I2C (Software) Data
21	TUN_RST	I	Tuner Reset Signal
22	TUN_SCLK	O	Tuner Serial Clock
23	LED_CTRL	O	Power On LED control
24	FLD_OUT	O	FL Display Data Out Signal
25	FLD_CLK	O	FL Display Clock Signal
26	FLD_STB	O	FL Display Strobe Signal
27	DVD_RX	I	DVD UART Receive
28	DVD_TX	O	DVD UART Transmit
29	DBG_TX	I	UART TX for Debug
30	DBG_RX	O	UART RX for Debug
31	SCLK	O	Clock Signal for Flash Writing
32	DAP_MUTE	O	Master mute for DAP
33	EDA	O	I2C EEPROM data
34	ECK	O	I2C EEPROM clock
35	NC	-	No Connection
36	FWD	O	Forward control for mechanism
37	REV	O	Reverse control for mechanism
38	AMUTE	O	Audio Muting
39	EPM	-	For Downloading Purpose
40	NC	-	No Connection
41	NC	-	No Connection
42	NC	-	No Connection
43	NC	-	No Connection
44	CE	I	For Downloading Purpose (with pull up)
45	NC	-	No Connection
46	NC	-	No Connection
47	NC	-	No Connection
48	PCONT	O	System Power Control
49	RGB_H	I/O	Blanking Signal for SCART
50	VMUTE	O	Video Muting
51	VBUS_EN	O	USB Vbus Supply Enable
52	USB_OC	O	USB Over-Current Protection
53	NC	-	No Connection
54	NC	-	No Connection
55	DCDET1	I	Power Supply Failure Detection (F76)
56	DCDET2	I	D-Amp and Fan Failure Detection (F61)
57	NC	-	No Connection

Pin No.	Terminal Name	I/O	Function
58	NC	-	No Connection
59	NC	-	No Connection
60	VCC	-	+3.3V System Supply
61	NC	-	No Connection
62	VSS	-	System Ground
63	NC	-	No Connection
64	NRST	O	ADC Reset
65	NC	-	No Connection
66	WIDE1	O	Signal to control SCART 16:9 or 4:3
67	NC	-	No Connection
68	NC	-	No Connection
69	NC	-	No Connection
70	NC	-	No Connection
71	NC	-	No Connection
72	NC	-	No Connection
73	VOL 0	O	For Energy Star (FL Power Control)
74	NC	-	No Connection
75	DAP_DAT	O	DAP/DSP data
76	DAP_CLK	O	DAP/DSP clock
77	NC	-	No Connection
78	NC	-	No Connection
79	DAP_RST	O	DAP Reset
80	DAP_PDN	O	DAP Power Down Control
81	VALID	O	DAP valid
82	SD	I	D-AMP Shutdown Signal
83	OTW	I	D-AMP Over Temperature Warning
84	NC	-	No Connection
85	NC	-	No Connection
86	DES 3	I	Model Series 2
87	NC	-	No connection
88	AUX_DET	I	Fan analog to digital control
89	KEY 2	I	Keyline 2:
90	KEY1	I	Keyline 1: 1st key is POWER During STOP mode; act as K10 After wake up; act as AN4
91	SEL_A	I	Analog Input Selector Control A
92	SEL_B	I	Analog Input Selector Control B
93	DES2	-	Model Selector
94	AVSS	-	Analog GND
95	DES1	-	Model Number
96	VREF	-	Voltage Reference +3.3V
97	AVCC	-	Analog +3.3V Supply
98	NC	-	No Connection
99	SPDIF_SW	O	Selector control for D-IN/ARC
100	OPEN_SW	I	Open Switch for BRS1D

19.4. IC901 (C0HBB0000057): IC FL Display Driver

Pin No.	Terminal Name	I/O	Function
1	USB RIP LED	-	No Connection
2	NC	-	No Connection
3	NC	-	No Connection
4	NC	-	No Connection
5	OSC	I	Oscillator Input
6	DOUT	-	No Connection
7	DIN	I	Data Input
8	CLK	I	Clock Input
9	STB	I	Serial Interface Strobe
10	K1	-	Key Data Input 1 (No Connection)
11	K2	-	Key Data Input 2 (No Connection)
12	GND	-	GND
13	VCC	-	Power Supply (+5V)
14	P18	O	No Connection
15	P17	O	No Connection
16	P16	O	Segment Output 16
17	P15	O	Segment Output 15
18	P14	O	Segment Output 14
19	P13	O	Segment Output 13
20	P12	O	Segment Output 12
21	P11	O	Segment Output 11
22	P10	O	Segment Output 10
23	P9	O	Segment Output 9
24	P8	O	Segment Output 8
25	P7	O	Segment Output 7
26	P6	O	Segment Output 6
27	P5	O	Segment Output 5
28	P4	O	Segment Output 4
29	P3	O	Segment Output 3
30	-VP	-	Voltage Supply
31	P2	O	Segment Output 2
32	P1	O	Segment Output 1
33	G1	O	Grid Segment Output 1
34	G2	O	Grid Segment Output 2
35	G3	O	Grid Segment Output 3
36	G4	O	Grid Segment Output 4
37	G5	O	Grid Segment Output 5
38	G6	O	Grid Segment Output 6
39	G7	O	Grid Segment Output 7
40	G8	O	Grid Segment Output 8
41	G9	O	Grid Segment Output 9
42	G10	O	Grid Segment Output 10
43	VCC	-	Voltage Supply (+5V)
44	GND	-	GND

20.1.2. Packaging

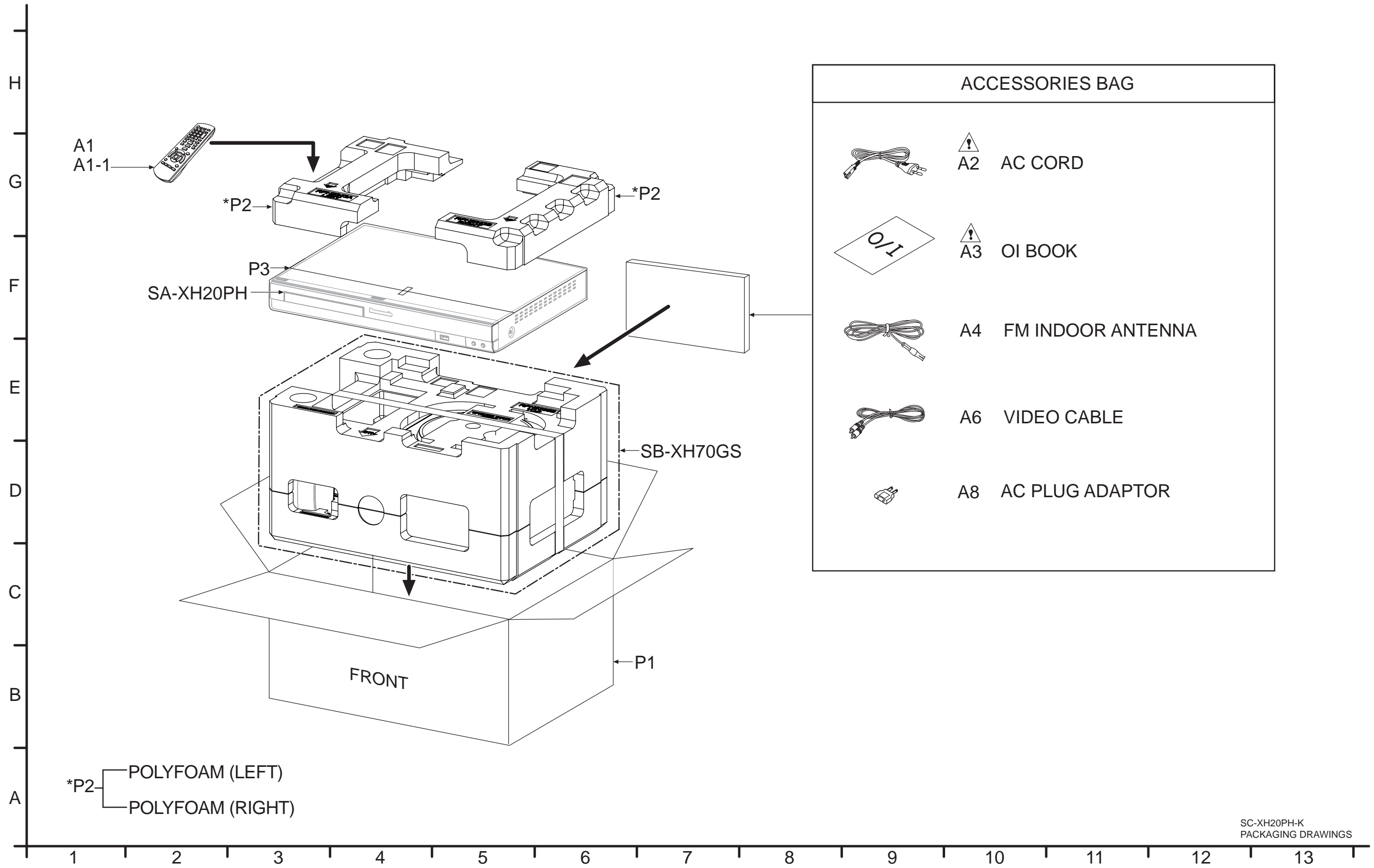

SC-XH20PH-K
 PACKAGING DRAWINGS

20.1.3. Mechanical Replacement Part List

Important Safety Notice

Components identified by Δ mark have special characteristics important for safety. When replacing any of these components, use only manufacturer's specified parts.

RTL (Retention Time Limited)

Note: The marking (RTL) indicates that the Retention Time is Limited for this item.

After the discontinuation of this assembly in production, the item will continue to be available for a specific period of time. The retention period of availability is dependant on the type of assembly, and in accordance with the laws governing part and product retention. After the end of this period, the assembly will no longer be available.

Note:

- When replacing any of these components, be sure to use only manufacturer's specified parts shown in the replacement part list.
- The parenthesized indications on the Remarks column specify the destination & product color (Refer to the cover page for the information).
- Parts without these indications shall be used for all areas.
- This product uses a laser diode. Refer to "Precaution of Laser Diode".
- All parts mentioned are supplied by PAVCSG unless indicated likewise.
- Parts mentioned [SPG] in the Remarks column are supplied by PAVC-CSG.
- Reference for O/I book languages are as follows:

Ar:	Arabic	Du:	Dutch	It:	Italian	Sp:	Spanish
Cf:	Canadian French	En:	English	Ko:	Korean	S:	Swedish
Cz:	Czech	Fr:	French	Po:	Polish	Co:	Traditional Chinese
Da:	Danish	Ge:	German	Ru:	Russian	Cn:	Simplified Chinese
Pe:	Persian	Ur:	Ukraine	Pr:	Portuguese		

Safety	Ref. No.	Part No.	Part Name & Description	Qty	Remarks
			CABINET AND CHASSIS		
	1	REEX1241	11P FFC COMPONENT VIDEO-BACK-END)	1	
	2	REEX1249-1	50P FFC (BACK-END-MAIN)	1	
	3	REEX1250-2J	17P FFC (MAIN-PANEL)	1	
	4	REXX1171	12P CABLE WIRE (SMPS-MAIN)	1	
	5	REXX1204	5P CABLE WIRE (PANEL-BACKEND)	1	
Δ	8	RGRX1004E-D1	REAR PANEL	1	
	9	RYPX1120J-K	FRONT PANEL ASS'Y	1	
	9-1	RGUX1029-K	POWER BUTTON	1	
	9-2	RGUX1030-K	VOLUME BUTTON	1	
	9-3	RGUX1043-K	OPEN/CLOSE BUTTON	1	
	10	RHD26043-1	SCREW	4	
	11	RHD26046	SCREW	5	
	12	RHD30007-K2J	SCREW	2	
	13	RHD30119-S	SCREW	11	
	14	RHDX301003	SCREW	12	
	15	RKA0253-H	LEG RUBBER	4	
Δ	16	RKM1009-K	TOP CABINET	1	
	17	RKWX1002	FL FILTER	1	
	18	RMCX0066	GROUND SPRING	1	
	19	RMKX1023	BOTTOM CHASSIS	1	
	20	RMNX0329-1	FL HOLDER	1	
Δ	21	RMNX1050	BOTTOM PC SHEET	1	

Safety	Ref. No.	Part No.	Part Name & Description	Qty	Remarks
	22	RMQ1742	HIMELON SHEET	1	
	23	RMZX1022	HEATSINK SPACER	3	
	24	RWJA003200XX	3P CABLE WIRE (PANEL-POWER BUTTON)	1	
	25	XTB3+10JFJ	SCREW	2	
	26	RGKX1049-K	TRAY ORNAMENT	1	
Δ	27	RMN1017	TOP PC SHEET	1	
	28	RMF0540	HIMELON SHEET	1	
			TRAVERSE DECK		
Δ	301	RAY1101-V	TRAVERSE ASS'Y	1	
			PACKING MATERIALS		
	P1	RPG9771	PACKING CASE	1	
	P2	RPN2343	POLYFOAM	1	
	P3	RPFX1010	MIRAMAT	1	
			ACCESSORIES		
	A1	N2QAYB000694	REMOTE CONTROL	1	
	A1-1	RKK-PM500EBK	R/C BATTERY COVER	1	
Δ	A2	K2CQ2CA00006	AC CORD	1	
Δ	A3	RQT9570-M	O/I BOOK (Sp)	1	
	A4	RSAX0002	FM INDOOR ANTENNA	1	
	A6	K2KA2BA00001	VIDEO CABLE	1	
	A8	K2DAYYY00002	AC PLUG ADAPTOR	1	

20.2. Electrical Replacement Parts List

Important Safety Notice

Components identified by Δ mark have special characteristics important for safety. When replacing any of these components, use only manufacturer's specified parts.

RTL (Retention Time Limited)

Note: The marking (RTL) indicates that the Retention Time is Limited for this item.

After the discontinuation of this assembly in production, the item will continue to be available for a specific period of time. The retention period of availability is dependant on the type of assembly, and in accordance with the laws governing part and product retention. After the end of this period, the assembly will no longer be available.

Note:

- When replacing any of these components, be sure to use only manufacturer's specified parts shown in the replacement part list.
- The parenthesized indications on the Remarks column specify the destination & product color (Refer to the cover page for the information).
- Parts without these indications shall be used for all areas.
- This product uses a laser diode. Refer to "Precaution of Laser Diode".
- Capacitor value are in microfarads (μ F) unless specified otherwise, P=Pico-farads (pF), F=Farads.
- Resistance values are in ohms, unless specified otherwise, 1K=1000 (OHM).
- All parts mentioned are supplied by PAVCSG unless indicated likewise.
- Parts mentioned [SPG] in the Remarks column are supplied by PAVC-CSG.

Safety	Ref. No.	Part No.	Part Name & Description	Qty	Remarks
			PRINTED CIRCUIT BOARDS		
	PCB1	REP4757G	BACKEND P.C.B	1	(RTL)
	PCB2	REP4756ET	MAIN P.C.B.	1	(RTL)
	PCB3	REP4765A	PANEL P.C.B.	1	(RTL)
	PCB3	REP4765A	POWER BUTTON P.C.B.	1	(RTL)
Δ	PCB5	REP4764C	SMPS P.C.B.	1	(RTL)
	PCB7	REP4767A	COMPONENT P.C.B.	1	(RTL)
			INTEGRATED CIRCUITS		
	IC100	C0ABBB000067	IC	1	
	IC106	C0DBAYY00927	IC	1	
	IC107	C0DBEYY00175	IC	1	
	IC200	RFKWMXH70EB	IC	1	
	IC201	C3EBFY000030	IC	1	
	IC202	C0DBGYY02930	IC	1	
	IC300	C0JBAR000367	IC	1	
	IC401	C1AB00003610	IC	1	
	IC403	C1AB00003217	IC	1	
	IC404	C1AB00003217	IC	1	
	IC405	C1AB00003217	IC	1	
	IC600	VUEALLPT040	IC	1	[SPG]
	IC700	C0FBAK000026	IC	1	
	IC901	C0HBB0000057	IC	1	
	IC2900	C0DBAYH000005	IC	1	
	IC3954	C0JBAR000433	IC	1	
	IC5701	C0DBZYY00448	IC	1	
	IC5702	C0DBZMC000006	IC	1	
	IC8001	C1AB00003477	IC	1	
	IC8051	C3ABPG000163	IC	1	
	IC8111	C0DBEYY00215	IC	1	
	IC8112	C0DBEYY00175	IC	1	

Safety	Ref. No.	Part No.	Part Name & Description	Qty	Remarks
	IC8251	C0GBY0000117	IC	1	
	IC8606	C0EBE0000504	IC	1	
	IC8651	RFKWFHXH170E	IC	1	
	IC9006	C0DBZYY00311	IC	1	
			TRANSISTORS		
	Q100	B1DGDC000002	TRANSISTOR	1	
	Q101	B1GBCFJJ0041	TRANSISTOR	1	
	Q102	DSA200100L	TRANSISTOR	1	
	Q105	B1ABCF000231	TRANSISTOR	1	
	Q106	B1GBCFJJ0041	TRANSISTOR	1	
	Q107	B1BABD000001	TRANSISTOR	1	
	Q114	B1ABBE000003	TRANSISTOR	1	
	Q116	DSA200100L	TRANSISTOR	1	
	Q122	B1ABCF000231	TRANSISTOR	1	
	Q123	B1GBCFGN0018	TRANSISTOR	1	
	Q124	B1GBCFGN0018	TRANSISTOR	1	
	Q300	B1GBCFJJ0041	TRANSISTOR	1	
	Q301	B1GBCFJJ0041	TRANSISTOR	1	
	Q500	B1ABCF000231	TRANSISTOR	1	
	Q501	B1ABCF000231	TRANSISTOR	1	
	Q2900	B1BABK000001	TRANSISTOR	1	
	Q5701	B1KAB0000021	TRANSISTOR	1	
	Q5841	B1GBCFGG0025	TRANSISTOR	1	
	Q8552	DSA200200L	TRANSISTOR	1	
	Q8562	DSA200200L	TRANSISTOR	1	
	Q8565	B1ABDF000026	TRANSISTOR	1	
			DIODES		
	D101	DZ2J056M0L	DIODE	1	
	D110	DA2J10100L	DIODE	1	
	D111	DA2J10100L	DIODE	1	
	D112	DZ2J07500L	DIODE	1	
	D114	DZ2J100M0L	DIODE	1	
	D115	DZ2J15000L	DIODE	1	
	D116	B0JCPG000028	DIODE	1	

Safety	Ref. No.	Part No.	Part Name & Description	Qty	Remarks
	D203	DZ2J07500L	DIODE	1	
	D402	DA2J10100L	DIODE	1	
	D901	DZ2J02400L	DIODE	1	
	D2901	DZ2J36000L	DIODE	1	
	D2903	B0EAMM000057	DIODE	1	
	D2906	B0EAMM000057	DIODE	1	
	D2907	B0JCPG000028	DIODE	1	
	D2908	B0EAMM000057	DIODE	1	
	D2909	DZ2J24000L	DIODE	1	
	D5701	B0EBNR000045	DIODE	1	
	D5702	B0EAKT000063	DIODE	1	
	D5703	B0EAMM000057	DIODE	1	
	D5704	B0JCME000035	DIODE	1	
	D5705	B0BC02700039	DIODE	1	
	D5706	B0HBSM000054	DIODE	1	
	D8101	B0ECKP000062	DIODE	1	
	D8102	B0ECKP000062	DIODE	1	
	D8251	DA3X103E0L	DIODE	1	
	D8301	DA3X101F0L	DIODE	1	
	D8302	DA3X101F0L	DIODE	1	
	D8303	DA3X101F0L	DIODE	1	
	D8304	DA3X101F0L	DIODE	1	
⚠	DZ5701	ERZVA5Z471	ZNR	1	
			VARISTOR		
	VA600	EZAEG2A50AX	VARISTOR	1	
			SWITCHES		
	S901	EVQ21405R	SW OPEN/CLOSE	1	
	S902	EVQ21405R	SW POWER	1	
	S905	EVQ21405R	SW VOL DOWN	1	
	S906	EVQ21405R	SW VOL UP	1	
			CONNECTORS		
	CN100	K1KA12AA0194	12P CONNECTOR	1	
	CN201	K1MN50AA0082	50P CONNECTOR	1	
	CN202	K1MN10AA0076	10P CONNECTOR	1	
	CN203	K1MY17AA0267	17P CONNECTOR	1	
	CN901	K1MY17AA0267	17P CONNECTOR	1	
	CN950	K1FY104A0007	USB CONNECTOR	1	
	CN4000	K1MY11AA0267	11P CONNECTOR	1	
	FP8001	K1KA05AA0051	5P CONNECTOR	1	
	FP8002	K1KA05AA0051	5P CONNECTOR	1	
	FP8101	K1MN50AA0082	50P CONNECTOR	1	
	FP8251	K1MN06AA0046	6P CONNECTOR	1	
	FP8252	K1MN05AA0046	5P CONNECTOR	1	
	FP8301	K1MN11AA0046	11P CONNECTOR	1	
	FP8531	K1MN24A00062	24P CONNECTOR	1	
	FP9001	K1KA05BA0014	5P CONNECTOR	1	
			COILS AND INDUCTORS		
	L125	GOA330G00016	CHOKE COIL	1	
	L291	J0JBC0000015	INDUCTOR	1	
	L292	J0JBC0000015	INDUCTOR	1	
	L402	GOA100H00018	CHOKE COIL	1	
	L403	GOA100H00018	CHOKE COIL	1	
	L404	GOA100H00018	CHOKE COIL	1	
	L405	GOA100H00018	CHOKE COIL	1	
	L406	GOA100H00018	CHOKE COIL	1	
	L407	GOA100H00018	CHOKE COIL	1	
	L408	GOA100H00018	CHOKE COIL	1	
	L409	GOA100H00018	CHOKE COIL	1	
	L410	GOA100H00018	CHOKE COIL	1	
	L417	GOA100H00018	CHOKE COIL	1	
	L418	GOA100H00018	CHOKE COIL	1	
	L419	GOA100H00018	CHOKE COIL	1	
	L427	J0JBC0000014	INDUCTOR	1	
	L600	G1CR18JA0020	INDUCTOR	1	

Safety	Ref. No.	Part No.	Part Name & Description	Qty	Remarks
	L2802	J0JBC0000015	INDUCTOR	1	
	L2900	GOA330G00016	CHOKE COIL	1	
⚠	L5701	GOB722G00002	LINE FILTER	1	
⚠	L5702	GOB453G00003	LINE FILTER	1	
	L8001	G1C100M00049	INDUCTOR	1	
	L8251	J0JHC0000117	INDUCTOR	1	
	L8252	J0JHC0000117	INDUCTOR	1	
	L8302	G1C100M00049	INDUCTOR	1	
	L8401	G1C100M00049	INDUCTOR	1	
	L8550	G1C100M00049	INDUCTOR	1	
	L8552	G1C100M00049	INDUCTOR	1	
	LB600	J0JBC0000032	INDUCTOR	1	
	LB700	J0JCC0000388	INDUCTOR	1	
	LB702	J0JCC0000388	INDUCTOR	1	
	LB703	J0JCC0000388	INDUCTOR	1	
	LB704	G1C100M00049	INDUCTOR	1	
	LB3901	J0JHC0000045	INDUCTOR	1	
	LB3902	J0JHC0000045	INDUCTOR	1	
	LB3907	J0JCC0000308	INDUCTOR	1	
	LB3910	J0JHC0000045	INDUCTOR	1	
	LB8001	J0JHC0000045	INDUCTOR	1	
	LB8011	J0JHC0000045	INDUCTOR	1	
	LB8051	J0JHC0000045	INDUCTOR	1	
	LB8121	J0JHC0000045	INDUCTOR	1	
	LB8301	J0JHC0000045	INDUCTOR	1	
	LB8401	J0JCC0000308	INDUCTOR	1	
	LB8530	J0JHC0000045	INDUCTOR	1	
	LB8532	J0JDC0000102	INDUCTOR	1	
	LB8551	J0JDC0000102	INDUCTOR	1	
	LB8561	J0JDC0000102	INDUCTOR	1	
	LB8651	J0JHC0000117	INDUCTOR	1	
	LB9001	J0JHC0000045	INDUCTOR	1	
	R5716	G1C220MA0172	INDUCTOR	1	
			FUSE		
⚠	F1	K5G312Y00007	FUSE	1	
			CABLE HOLDERS		
	H901	K1YZ03000010	3P CABLE HOLDER	1	
	H902	K1YZ03000010	3P CABLE HOLDER	1	
			TRANSFORMERS		
⚠	T2900	G4D1A0000142	SWITCHING TRANSFORMER	1	
⚠	T5701	ETS35BL146AC	SWITCHING TRANSFORMER	1	
			PHOTO COUPLER		
⚠	PC701	B3PBA0000579	PHOTO COUPLER	1	
			TERMINALS		
	ZJ5701	K4CZ01000027	TERMINAL	1	
	ZJ5702	K4CZ01000027	TERMINAL	1	
			OSCILLATORS		
	X201	H2D500400006	CRYSTAL OSCILLATOR	1	
	X400	H0J135500050	CRYSTAL OSCILLATOR	1	
	X600	H0A327200097	CRYSTAL OSCILLATOR	1	
	X8621	H0J270500131	CRYSTAL OSCILLATOR	1	
			FL DISPLAY		
	FL901	A2BB00000175	FL DISPLAY	1	

Safety	Ref. No.	Part No.	Part Name & Description	Qty	Remarks
			IR SENSOR		
	Z901	B3RAB0000081	IR SENSOR	1	
			THERMISTORS		
△	TH5701	D4CC11040013	THERMISTOR	1	
△	TH5702	D4CAA5R10001	THERMISTOR	1	
			JACKS		
	JK300	K2HA2YYA0005	JK AUX	1	
	JK401	K4AL12B00006	JK SPEAKER	1	
	JK600	K4ZZ01000276	JK FM ANT	1	
	JK4000	K2HA3YYB0015	JK COMPONENT VIDEO OUT	1	
	JK8001	B3RAB0000056	JK DIGITAL AUDIO IN (OPTICAL)	1	
	JK8301	K2HA1YYB0029	JK VIDEO OUT	1	
△	P5701	K2AA2B000011	AC INLET	1	
			CHIP JUMPERS		
	K7	D0GBR00JA008	0 1/10W	1	
	K101	D0GBR00JA008	0 1/10W	1	
	K102	D0GBR00JA008	0 1/10W	1	
	K103	D0GBR00JA008	0 1/10W	1	
	K104	D0GBR00JA008	0 1/10W	1	
	K105	D0GBR00JA008	0 1/10W	1	
	K106	D0GBR00JA008	0 1/10W	1	
	K107	D0GBR00JA008	0 1/10W	1	
	K109	D0GBR00JA008	0 1/10W	1	
	K153	D0GBR00JA008	0 1/10W	1	
	K154	D0GBR00JA008	0 1/10W	1	
	K155	D0GBR00JA008	0 1/10W	1	
	K156	D0GBR00JA008	0 1/10W	1	
	K157	D0GBR00JA008	0 1/10W	1	
	K158	D0GBR00JA008	0 1/10W	1	
	K301	D0GFR00JA017	0 1/2W	1	
	K303	D0GFR00JA017	0 1/2W	1	
	K304	D0GBR00JA008	0 1/10W	1	
	K305	D0GFR00JA017	0 1/2W	1	
	K400	D0GBR00JA008	0 1/10W	1	
	K600	D0GFR00JA017	0 1/2W	1	
	K700	D0GBR00JA008	0 1/10W	1	
	K955	D0GBR00JA008	0 1/10W	1	
	K960	D0GBR00JA008	0 1/10W	1	
	K8002	D0GAR00J0005	0 1/16W	1	
	K8003	D0GAR00J0005	0 1/16W	1	
	K8007	D0GAR00J0005	0 1/16W	1	
	K8008	D0GAR00J0005	0 1/16W	1	
	K8102	D0GBR00JA008	0 1/10W	1	
	K8251	D0GBR00JA008	0 1/10W	1	
	K8252	D0GBR00JA008	0 1/10W	1	
	L100	D0GBR00JA008	0 1/10W	1	
	L290	D0GDR00JA017	0 1/8W	1	
	L426	D0GBR00JA008	0 1/10W	1	
	L4003	D0GBR00JA008	0 1/10W	1	
	L4004	D0GBR00JA008	0 1/10W	1	
	L4005	D0GBR00JA008	0 1/10W	1	
	LB200	D0GBR00JA008	0 1/10W	1	
	LB201	D0GBR00JA008	0 1/10W	1	
	LB202	D0GBR00JA008	0 1/10W	1	
	LB701	D0GBR00JA008	0 1/10W	1	
	LB950	D0GDR00JA017	0 1/8W	1	
	LB951	D0GDR00JA017	0 1/8W	1	
	LB8012	D0GBR00JA008	0 1/10W	1	
	LB8317	D0GAR00J0005	0 1/16W	1	
	LB9002	D0GBR00JA008	0 1/10W	1	
	LB9003	D0GBR00JA008	0 1/10W	1	
	W921	D0GDR00JA017	0 1/8W	1	
	W929	D0GBR00JA008	0 1/10W	1	
	W930	D0GBR00JA008	0 1/10W	1	

Safety	Ref. No.	Part No.	Part Name & Description	Qty	Remarks
	W933	D0GBR00JA008	0 1/10W	1	
	W940	D0GBR00JA008	0 1/10W	1	
			RESISTORS		
	LB8531	D0GA220JA023	22 1/16W	1	
	LB8691	D0GA101JA023	100 1/16W	1	
	LB8692	D0GA101JA023	100 1/16W	1	
	R101	D0GB220JA008	22 1/10W	1	
	R102	D0GB392JA008	3.9K 1/10W	1	
	R131	D0GBR00JA008	0 1/10W	1	
	R135	D0GBR00JA008	0 1/10W	1	
	R136	D0GBR00JA008	0 1/10W	1	
	R137	D0GBR00JA008	0 1/10W	1	
	R139	D0GBR00JA008	0 1/10W	1	
	R141	D0GBR00JA008	0 1/10W	1	
	R142	D0GBR00JA008	0 1/10W	1	
	R144	D0GBR00JA008	0 1/10W	1	
	R145	D0GBR00JA008	0 1/10W	1	
	R150	D0GB473JA008	47K 1/10W	1	
	R152	D0GB203JA008	20K 1/10W	1	
	R156	D0GB122JA008	1.2K 1/10W	1	
	R157	D0GB101JA008	100 1/10W	1	
	R162	D0HB123ZA002	12K 1/16W	1	
	R163	ERJ3RBD563V	56K 1/16W	1	
	R164	D0GB102JA008	1K 1/10W	1	
	R165	ERJ3RBD153V	15K 1/16W	1	
	R178	D0GB473JA008	47K 1/10W	1	
	R179	D0GB224JA008	220K 1/10W	1	
	R180	D0GB224JA008	220K 1/10W	1	
	R183	D0GD102JA017	1K 1/8W	1	
	R185	D0GB103JA008	10K 1/10W	1	
	R186	D0GB473JA008	47K 1/10W	1	
	R187	D0GB155JA008	1.5M 1/10W	1	
	R188	D0GB123JA008	12K 1/10W	1	
	R189	D0GB223JA008	22K 1/10W	1	
	R190	D0GB223JA008	22K 1/10W	1	
	R191	D0GB123JA008	12K 1/10W	1	
	R192	D0GB155JA008	1.5M 1/10W	1	
	R195	D0GB104JA008	100K 1/10W	1	
	R196	D0GB103JA008	10K 1/10W	1	
	R200	D0GB273JA008	27K 1/10W	1	
	R201	D0GB221JA008	220 1/10W	1	
	R202	D0GB103JA008	10K 1/10W	1	
	R203	D0GB103JA008	10K 1/10W	1	
	R205	D0GB103JA008	10K 1/10W	1	
	R206	D0GB103JA008	10K 1/10W	1	
	R207	D0GB103JA008	10K 1/10W	1	
	R208	D0GB103JA008	10K 1/10W	1	
	R209	D0GB103JA008	10K 1/10W	1	
	R210	D0GB102JA008	1K 1/10W	1	
	R214	D0GB101JA008	100 1/10W	1	
	R215	D0GB101JA008	100 1/10W	1	
	R216	D0GB101JA008	100 1/10W	1	
	R217	D0GB102JA008	1K 1/10W	1	
	R222	D0GB154JA008	150K 1/10W	1	
	R223	D0GB122JA008	1.2K 1/10W	1	
	R228	D0GB100JA008	10 1/10W	1	
	R229	D0GB100JA008	10 1/10W	1	
	R231	D0GB563JA008	56K 1/10W	1	
	R232	D0GB221JA008	220 1/10W	1	
	R233	D0GB221JA008	220 1/10W	1	
	R234	D0GB472JA008	4.7K 1/10W	1	
	R235	D0GB472JA008	4.7K 1/10W	1	
	R236	D0GB563JA008	56K 1/10W	1	
	R239	D0GB103JA008	10K 1/10W	1	
	R241	D0GB103JA008	10K 1/10W	1	
	R242	D0GB102JA008	1K 1/10W	1	
	R243	D0GB221JA008	220 1/10W	1	
	R246	D0GB221JA008	220 1/10W	1	
	R247	D0GB221JA008	220 1/10W	1	
	R248	D0GB473JA008	47K 1/10W	1	
	R249	D0GB472JA008	4.7K 1/10W	1	

Safety	Ref. No.	Part No.	Part Name & Description	Qty	Remarks
	R250	D0GB221JA008	220 1/10W	1	
	R272	D0GBR00JA008	0 1/10W	1	
	R282	D0GBR00JA008	0 1/10W	1	
	R283	D0GBR00JA008	0 1/10W	1	
	R284	D0GBR00JA008	0 1/10W	1	
	R285	D0GBR00JA008	0 1/10W	1	
	R286	D0GBR00JA008	0 1/10W	1	
	R287	D0GBR00JA008	0 1/10W	1	
	R291	D0GB104JA008	100K 1/10W	1	
	R292	D0GB393JA008	39K 1/10W	1	
	R293	D0GB273JA008	27K 1/10W	1	
	R294	D0GB473JA008	47K 1/10W	1	
	R295	D0GBR00JA008	0 1/10W	1	
	R296	D0GBR00JA008	0 1/10W	1	
	R300	D0GBR00JA008	0 1/10W	1	
	R302	D0GBR00JA008	0 1/10W	1	
	R304	D0GBR00JA008	0 1/10W	1	
	R307	D0GB102JA008	1K 1/10W	1	
	R308	D0GB102JA008	1K 1/10W	1	
	R309	D0GB103JA008	10K 1/10W	1	
	R310	D0GB103JA008	10K 1/10W	1	
	R311	D0GBR00JA008	0 1/10W	1	
	R312	D0GB103JA008	10K 1/10W	1	
	R313	D0GB103JA008	10K 1/10W	1	
	R314	D0GB102JA008	1K 1/10W	1	
	R315	D0GB153JA008	15K 1/10W	1	
	R316	D0GB273JA008	27K 1/10W	1	
	R317	D0GB153JA008	15K 1/10W	1	
	R318	D0GB273JA008	27K 1/10W	1	
	R326	D0GB102JA008	1K 1/10W	1	
	R327	D0GB103JA008	10K 1/10W	1	
	R328	D0GB103JA008	10K 1/10W	1	
	R329	D0GB103JA008	10K 1/10W	1	
	R330	D0GB103JA008	10K 1/10W	1	
	R400	D0GB221JA008	220 1/10W	1	
	R401	D0GB221JA008	220 1/10W	1	
	R402	D0GB3R3JA008	3.3 1/10W	1	
	R404	D0GB105JA008	1M 1/10W	1	
	R405	D0GB103JA008	10K 1/10W	1	
	R411	D0GBR00JA008	0 1/10W	1	
	R414	D0GB103JA008	10K 1/10W	1	
	R425	D0GFR00JA017	0 1/4W	1	
	R427	D0GB100JA008	10 1/10W	1	
	R428	D0GB100JA008	10 1/10W	1	
	R429	D0GB101JA008	100 1/10W	1	
	R435	D0GB101JA008	100 1/10W	1	
	R436	D0GB102JA008	1K 1/10W	1	
	R437	ERJ3RBD473V	47K 1/16W	1	
	R438	ERJ3RBD153V	15K 1/16W	1	
	R440	D0GB101JA008	100 1/10W	1	
	R441	D0GB223JA008	22K 1/10W	1	
	R442	D0GB101JA008	100 1/10W	1	
	R443	D0GB100JA008	10 1/10W	1	
	R444	D0GB100JA008	10 1/10W	1	
	R445	D0GB100JA008	10 1/10W	1	
	R446	D0GB100JA008	10 1/10W	1	
	R447	D0GB100JA008	10 1/10W	1	
	R448	D0GB101JA008	100 1/10W	1	
	R449	D0GB101JA008	100 1/10W	1	
	R450	D0GB223JA008	22K 1/10W	1	
	R451	D0GB101JA008	100 1/10W	1	
	R452	D0GB100JA008	10 1/10W	1	
	R453	D0GB100JA008	10 1/10W	1	
	R454	D0GB100JA008	10 1/10W	1	
	R455	D0GB100JA008	10 1/10W	1	
	R456	D0GB100JA008	10 1/10W	1	
	R457	D0GB101JA008	100 1/10W	1	
	R458	D0GB101JA008	100 1/10W	1	
	R459	D0GB223JA008	22K 1/10W	1	
	R460	D0GB101JA008	100 1/10W	1	
	R461	D0GB100JA008	10 1/10W	1	
	R462	D0GB100JA008	10 1/10W	1	
	R463	D0GB100JA008	10 1/10W	1	

Safety	Ref. No.	Part No.	Part Name & Description	Qty	Remarks
	R464	D0GB3R3JA008	3.3 1/10W	1	
	R465	D0GB3R3JA008	3.3 1/10W	1	
	R466	D0GB3R3JA008	3.3 1/10W	1	
	R467	D0GB3R3JA008	3.3 1/10W	1	
	R468	D0GB3R3JA008	3.3 1/10W	1	
	R469	D0GB3R3JA008	3.3 1/10W	1	
	R495	D0GB101JA008	100 1/10W	1	
	R496	D0GB3R3JA008	3.3 1/10W	1	
	R497	D0GB3R3JA008	3.3 1/10W	1	
	R498	D0GB3R3JA008	3.3 1/10W	1	
	R499	D0GB3R3JA008	3.3 1/10W	1	
	R500	D0GB562JA008	5.6K 1/10W	1	
	R501	D0GB562JA008	5.6K 1/10W	1	
	R502	D0GB562JA008	5.6K 1/10W	1	
	R503	D0GB562JA008	5.6K 1/10W	1	
	R504	D0GB562JA008	5.6K 1/10W	1	
	R505	D0GB562JA008	5.6K 1/10W	1	
	R506	D0GB3R3JA008	3.3 1/10W	1	
	R507	D0GB3R3JA008	3.3 1/10W	1	
	R520	D0GB104JA008	100K 1/10W	1	
	R521	D0GB104JA008	100K 1/10W	1	
	R522	D0GB333JA008	33K 1/10W	1	
	R523	D0GB104JA008	100K 1/10W	1	
	R524	D0GB104JA008	100K 1/10W	1	
	R525	D0GB104JA008	100K 1/10W	1	
	R526	D0GB104JA008	100K 1/10W	1	
	R527	D0GB104JA008	100K 1/10W	1	
	R528	D0GB104JA008	100K 1/10W	1	
	R529	D0GB104JA008	100K 1/10W	1	
	R530	D0GB104JA008	100K 1/10W	1	
	R531	D0GB104JA008	100K 1/10W	1	
	R532	D0GB104JA008	100K 1/10W	1	
	R587	D0GB563JA008	56K 1/10W	1	
	R600	D0GB102JA008	1K 1/10W	1	
	R601	D0GB102JA008	1K 1/10W	1	
	R602	D0GA472JA023	4.7K 1/16W	1	
	R603	D0GA472JA023	4.7K 1/16W	1	
	R604	D0GA221JA023	220 1/16W	1	
	R605	D0GB221JA008	220 1/10W	1	
	R606	D0GA102JA023	1K 1/16W	1	
	R609	D0GB473JA008	47K 1/10W	1	
	R610	D0GB473JA008	47K 1/10W	1	
	R613	D0GB102JA008	1K 1/10W	1	
	R614	D0GB102JA008	1K 1/10W	1	
	R615	D0GB473JA008	47K 1/10W	1	
	R616	D0GB473JA008	47K 1/10W	1	
	R630	D0GBR00JA008	0 1/10W	1	
	R631	D0GBR00JA008	0 1/10W	1	
	R632	D0GBR00JA008	0 1/10W	1	
	R633	D0GBR00JA008	0 1/10W	1	
	R658	D0GB222JA008	2.2K 1/10W	1	
	R700	D0GB101JA008	100 1/10W	1	
	R701	D0GBR00JA008	0 1/10W	1	
	R702	D0GB4R7JA008	4.7 1/10W	1	
	R703	D0GB102JA008	1K 1/10W	1	
	R901	D0GB680JA008	68 1/10W	1	
	R903	D0GB680JA008	68 1/10W	1	
	R904	D0GB680JA008	68 1/10W	1	
	R905	D0GB823JA008	82K 1/10W	1	
	R908	D0GB122JA008	1.2K 1/10W	1	
	R913	D0GB122JA008	1.2K 1/10W	1	
	R914	D0GB183JA008	18K 1/10W	1	
	R922	D0GB470JA008	47 1/10W	1	
	R923	D0GB223JA008	22K 1/10W	1	
	R924	D0GB100JA008	10 1/10W	1	
	R950	D0GBR00JA008	0 1/10W	1	
	R951	D0GBR00JA008	0 1/10W	1	
	R952	D0GBR00JA008	0 1/10W	1	
	R2900	D0GB472JA008	4.7K 1/10W	1	
	R2901	D0GBR00JA008	0 1/10W	1	
	R2902	D0GB470JA008	47 1/10W	1	
	R2903	D0GB3R3JA008	3.3 1/10W	1	
	R2905	ERJ3RBD472V	4.7K 1/16W	1	

Safety	Ref. No.	Part No.	Part Name & Description	Qty	Remarks
	R2906	ERJ3RBD303V	30K 1/16W	1	
	R2907	D0HB392ZA002	3.9K 1/16W	1	
	R2908	D0GB103JA008	10K 1/10W	1	
	R2909	D0GB102JA008	1K 1/10W	1	
	R2914	D0GB473JA008	47K 1/10W	1	
	R3901	ERJ2RHD4020X	402 1/16W	1	
	R3908	D0GA103JA023	10K 1/16W	1	
	R3910	D0GB100JA008	10 1/10W	1	
	R4014	D0GBR00JA008	0 1/10W	1	
	R4015	D0GBR00JA008	0 1/10W	1	
	R4016	D0GBR00JA008	0 1/10W	1	
⚠	R5701	D0GB824JA008	820K 1/10W	1	
⚠	R5702	D0GB824JA008	820K 1/10W	1	
⚠	R5703	D0GB824JA008	820K 1/10W	1	
⚠	R5704	D0GB824JA008	820K 1/10W	1	
	R5710	ERJ1TYJ104U	100K 1W	1	
	R5711	ERJ1TYJ104U	100K 1W	1	
	R5713	ERX2SZJR11P	0.11 2W	1	
	R5714	D0GF100JA048	10 1/2W	1	
	R5715	D0GF4R7JA017	4.7 1/2W	1	
	R5717	D0GB333JA008	33K 1/10W	1	
	R5718	D0GB102JA008	1K 1/10W	1	
	R5719	D0GB335JA008	3.3M 1/10W	1	
	R5720	D0GB335JA008	3.3M 1/10W	1	
	R5721	D0GB335JA008	3.3M 1/10W	1	
	R5722	D0GB823JA008	82K 1/10W	1	
	R5723	D0GB123JA008	12K 1/10W	1	
	R5724	D0GB184JA008	180K 1/10W	1	
	R5726	D0GB470JA008	47 1/10W	1	
	R5728	D0GB331JA008	330 1/10W	1	
	R5729	D0GB153JA008	15K 1/10W	1	
	R5730	ERJ3RBD472V	4.7K 1/16W	1	
	R5731	ERJ3RBD393V	39K 1/16W	1	
	R5735	D0HB102ZA002	1K 1/16W	1	
	R5817	D0GBR00JA008	0 1/10W	1	
	R5842	D0GB471JA008	470 1/10W	1	
	R5843	D0GB222JA008	2.2K 1/10W	1	
	R8010	D0GB103JA008	10K 1/10W	1	
	R8011	D0GA220JA023	22 1/16W	1	
	R8016	D0GA101JA023	100 1/16W	1	
	R8025	D0GBR00JA008	0 1/10W	1	
	R8050	ERJ2RHD1542X	15.4K 1/16W	1	
	R8051	D0GA103JA023	10K 1/16W	1	
	R8101	ERJ2RKD2703X	270K 1/16W	1	
	R8102	ERJ2RKD1303X	130K 1/16W	1	
	R8103	ERJ3RBD473V	47K 1/16W	1	
	R8104	ERJ3RBD153V	15K 1/16W	1	
	R8221	ERJ2RHD2202X	22K 1/16W	1	
	R8225	ERJ2RHD5102X	51K 1/16W	1	
	R8227	ERJ2RHD5102X	51K 1/16W	1	
	R8229	ERJ2RHD5102X	51K 1/16W	1	
	R8253	D0GB2R2JA065	2.2 1/10W	1	
	R8254	D0GB2R2JA065	2.2 1/10W	1	
	R8255	D0GA202JA023	2K 1/16W	1	
	R8256	D0GA202JA023	2K 1/16W	1	
	R8258	ERJ2RHD6191X	6.19K 1/16W	1	
	R8259	D0GA103JA023	10K 1/16W	1	
	R8260	D0GA103JA023	10K 1/16W	1	
	R8261	D0GA103JA023	10K 1/16W	1	
	R8262	D0GA103JA023	10K 1/16W	1	
	R8263	D0GA472JA023	4.7K 1/16W	1	
	R8264	ERJ2RHD1001X	1K 1/16W	1	
	R8265	ERJ2RHD1001X	1K 1/16W	1	
	R8266	ERJ2RHD1001X	1K 1/16W	1	
	R8267	ERJ2RHD1001X	1K 1/16W	1	
	R8268	D0GA333JA023	33K 1/16W	1	
	R8311	ERJ2RHD3920X	392 1/16W	1	
	R8321	ERJ2RKD75R0X	75 1/16W	1	
	R8322	ERJ2RKD75R0X	75 1/16W	1	
	R8323	ERJ2RKD75R0X	75 1/16W	1	
	R8324	ERJ2RKD75R0X	75 1/16W	1	
	R8325	D0GBR00JA008	0 1/10W	1	

Safety	Ref. No.	Part No.	Part Name & Description	Qty	Remarks
	R8326	D0GBR00JA008	0 1/10W	1	
	R8401	D0GAR00J0005	0 1/16W	1	
	R8402	D0GA101JA023	100 1/16W	1	
	R8404	D0GA101JA023	100 1/16W	1	
	R8411	ERJ2RHD6191X	6.19K 1/16W	1	
	R8531	D0GAR00J0005	0 1/16W	1	
	R8532	D0GAR00J0005	0 1/16W	1	
	R8534	D0GA103JA023	10K 1/16W	1	
	R8535	D0GA473JA023	47K 1/16W	1	
	R8536	D0GA332JA023	3.3K 1/16W	1	
	R8537	D0GAR00J0005	0 1/16W	1	
	R8538	D0GAR00J0005	0 1/16W	1	
	R8542	D0GAR00J0005	0 1/16W	1	
	R8554	D0GA221JA023	220 1/16W	1	
	R8556	D0GB4R7JA008	4.7 1/10W	1	
	R8564	D0GA221JA023	220 1/16W	1	
	R8566	D0GB4R7JA008	4.7 1/10W	1	
	R8569	D0GA102JA023	1K 1/16W	1	
	R8601	D0GA102JA023	1K 1/16W	1	
	R8602	D0GA102JA023	1K 1/16W	1	
	R8621	D0GA224JA023	220K 1/16W	1	
	R8622	D0GA221JA023	220 1/16W	1	
	R8651	D0GA472JA023	4.7K 1/16W	1	
	R8652	D0GA472JA023	4.7K 1/16W	1	
	R8653	D0GA220JA023	22 1/16W	1	
	R8654	D0GA472JA023	4.7K 1/16W	1	
	R9001	D0GAR00J0005	0 1/16W	1	
	R9002	D0GAR00J0005	0 1/16W	1	
			RESISTOR NETWORKS		
	RX201	D1H81014A024	RESISTOR NETWORK	1	
	RX202	D1H81034A024	RESISTOR NETWORK	1	
	RX203	D1H81034A024	RESISTOR NETWORK	1	
	RX204	D1H84734A024	RESISTOR NETWORK	1	
	RX205	D1H81014A024	RESISTOR NETWORK	1	
	RX401	D1H84704A024	RESISTOR NETWORK	1	
	RX402	D1H84704A024	RESISTOR NETWORK	1	
	RX403	D1H84704A024	RESISTOR NETWORK	1	
	RX404	D1H84704A024	RESISTOR NETWORK	1	
	RX405	D1H84704A024	RESISTOR NETWORK	1	
	RX8011	D1H88204A043	RESISTOR NETWORK	1	
	RX8012	D1H88204A043	RESISTOR NETWORK	1	
	RX8013	D1H88204A043	RESISTOR NETWORK	1	
	RX8014	D1H88204A043	RESISTOR NETWORK	1	
	RX8015	D1H88204A043	RESISTOR NETWORK	1	
	RX8016	D1H88204A043	RESISTOR NETWORK	1	
	RX8017	D1H88204A043	RESISTOR NETWORK	1	
	RX8018	D1H88204A043	RESISTOR NETWORK	1	
	RX8019	D1H88204A043	RESISTOR NETWORK	1	
	RX8401	D1H45602001	RESISTOR NETWORK	1	
	RX8402	D1H45602001	RESISTOR NETWORK	1	
	RX8531	D1H45602001	RESISTOR NETWORK	1	
	RX8532	D1H45602001	RESISTOR NETWORK	1	
			CAPACITORS		
	C100	F2A1A1010024	100uF 10V	1	
	C101	F1H1H104B055	0.1uF 50V	1	
	C102	F2A1E470B389	47uF 25V	1	
	C109	F1H1A225A025	2.2uF 10V	1	
	C110	F1H1A105A025	1uF 10V	1	
	C121	F1H1A105A025	1uF 10V	1	
	C122	F1H1A105A025	1uF 10V	1	
	C124	F1H1A105A025	1uF 10V	1	
	C129	F1H1H104B055	0.1uF 50V	1	
	C130	F1H1H153B047	0.015uF 50V	1	
	C131	F1H1H181B052	180pF 50V	1	
	C132	F1H1H102B047	1000pF 50V	1	
	C133	F1H1A105A025	1uF 10V	1	
	C135	F1H1H103B047	0.01uF 50V	1	
	C138	F1K1C226A121	22uF 16V	1	

Safety	Ref. No.	Part No.	Part Name & Description	Qty	Remarks
	C139	F1K1C1050005	1uF 16V	1	
	C140	F1H1H100A017	10pF 50V	1	
	C141	F1H1C474A179	0.47uF 16V	1	
	C142	F2A1E4R7B384	4.7uF 25V	1	
	C143	F2A1E471B394	470uF 25V	1	
	C150	F2A1C471B457	470uF 16V	1	
	C151	F2A1C1010033	100uF 16V	1	
	C158	F1H1H104B055	0.1uF 50V	1	
	C181	F1H1H102B047	1000pF 50V	1	
	C182	F1H1H102B047	1000pF 50V	1	
	C183	F1H1H102B047	1000pF 50V	1	
	C184	F1H1H102B047	1000pF 50V	1	
	C185	F1H1H102B047	1000pF 50V	1	
	C186	F1H1H102B047	1000pF 50V	1	
	C187	F1H1H102B047	1000pF 50V	1	
	C188	F1H1H102B047	1000pF 50V	1	
	C189	F1H1H102B047	1000pF 50V	1	
	C190	F1H1H102B047	1000pF 50V	1	
	C191	F1H1H102B047	1000pF 50V	1	
	C192	F1H1H102B047	1000pF 50V	1	
	C195	F1H1H100A017	10pF 50V	1	
	C197	F1H1H104B055	0.1uF 50V	1	
	C198	F1H1A105A036	1uF 10V	1	
	C200	F1H1H223B047	0.022uF 16V	1	
	C201	F1H1H104B055	0.1uF 50V	1	
	C202	F1H1H104B055	0.1uF 50V	1	
	C205	F1H1C474A179	0.47uF 16V	1	
	C207	F1H1H104B055	0.1uF 50V	1	
	C209	F1H1H561B052	560pF 50V	1	
	C210	F1H1H561B052	560pF 50V	1	
	C214	F1H1C474A179	0.47uF 16V	1	
	C219	F1H1H103B047	0.01uF 50V	1	
	C304	F1H1A105A036	1uF 10V	1	
	C306	F1H1A105A036	1uF 10V	1	
	C307	F1H1A105A036	1uF 10V	1	
	C308	F1H1H681B052	680pF 50V	1	
	C309	F1H1H681B052	680pF 50V	1	
	C312	F1H1A105A036	1uF 10V	1	
	C313	F1H1A105A036	1uF 10V	1	
	C314	F1H1A105A036	1uF 10V	1	
	C315	F1H1H470B052	47pF 50V	1	
	C316	F1H1H470B052	47pF 50V	1	
	C317	F1H1H104B055	0.1uF 50V	1	
	C328	F1H1H221B052	220pF 50V	1	
	C329	F1H1H221B052	220pF 50V	1	
	C400	F1H1H104B055	0.1uF 50V	1	
	C401	F1H1H104B055	0.1uF 50V	1	
	C402	F1H1H104B055	0.1uF 50V	1	
	C403	F1H1H104B055	0.1uF 50V	1	
	C404	F1H1H104B055	0.1uF 50V	1	
	C405	F1H1H104B055	0.1uF 50V	1	
	C406	F2A1C100A207	10uF 16V	1	
	C407	F1H1H104B055	0.1uF 50V	1	
	C408	F2A1C100A207	10uF 16V	1	
	C409	F1H1H102B047	1000pF 50V	1	
	C410	F2A1C100A207	10uF 16V	1	
	C411	F1H1H104B055	0.1uF 50V	1	
	C412	F1H1H104B055	0.1uF 50V	1	
	C413	F1H1H8R0B051	8pF 50V	1	
	C414	F1H1H103B047	0.01uF 50V	1	
	C415	F1H1H100B051	10pF 50V	1	
	C416	F1H1H104B055	0.1uF 50V	1	
	C417	F1H1H104B055	0.1uF 50V	1	
	C418	F1H1A105A036	1uF 10V	1	
	C419	F1H1A105A036	1uF 10V	1	
	C420	F2A1C100A207	10uF 16V	1	
	C421	F1H1H104B055	0.1uF 50V	1	
	C423	F1H1H104B055	0.1uF 50V	1	
	C424	F1H1H104B055	0.1uF 50V	1	
	C425	F1H1H104B055	0.1uF 50V	1	
	C426	F1H1H104B055	0.1uF 50V	1	
	C427	F1J1C106A059	10uF 16V	1	
	C429	F1H1H104B055	0.1uF 50V	1	

Safety	Ref. No.	Part No.	Part Name & Description	Qty	Remarks
	C430	F1H1H104B055	0.1uF 50V	1	
	C431	F1H1H104B055	0.1uF 50V	1	
	C432	F1H1H104B055	0.1uF 50V	1	
	C433	F1J1C106A059	10uF 16V	1	
	C434	F1H1H104B055	0.1uF 50V	1	
	C436	F1H1H104B055	0.1uF 50V	1	
	C437	F1H1H104B055	0.1uF 50V	1	
	C438	F1H1H104B055	0.1uF 50V	1	
	C439	F1J1C106A059	10uF 16V	1	
	C441	F2A1C330B453	33uF 16V	1	
	C442	F1H1H103B047	0.01uF 50V	1	
	C443	F1H1H103B047	0.01uF 50V	1	
	C444	F1H1H103B047	0.01uF 50V	1	
	C445	F1H1H103B047	0.01uF 50V	1	
	C446	F1H1H103B047	0.01uF 50V	1	
	C447	F1H1H103B047	0.01uF 50V	1	
	C448	F1H1H103B047	0.01uF 50V	1	
	C449	F1H1H103B047	0.01uF 50V	1	
	C450	F1H1H103B047	0.01uF 50V	1	
	C451	F1H1H150B052	15pF 50V	1	
	C452	F1H1H150B052	15pF 50V	1	
	C453	F1H1H103B047	0.01uF 50V	1	
	C454	F1H1H103B047	0.01uF 50V	1	
	C455	F1H1H103B047	0.01uF 50V	1	
	C456	F1H1H103B047	0.01uF 50V	1	
	C460	F1H1H104B055	0.1uF 50V	1	
	C461	F1H1H104B055	0.1uF 50V	1	
	C462	F1H1H104B055	0.1uF 50V	1	
	C464	F1H1H333B055	0.033uF 50V	1	
	C467	F2A1E331B423	330uF 25V	1	
	C470	F1H1H333B055	0.033uF 50V	1	
	C471	F1H1H104B055	0.1uF 50V	1	
	C472	F1H1H104B055	0.1uF 50V	1	
	C473	F1H1H104B055	0.1uF 50V	1	
	C476	F1H1H333B055	0.033uF 50V	1	
	C477	F1H1H104B055	0.1uF 50V	1	
	C478	F1H1H104B055	0.1uF 50V	1	
	C479	F1H1H333B055	0.033uF 50V	1	
	C481	F1H1H104B055	0.1uF 50V	1	
	C486	F1H1H104B055	0.1uF 50V	1	
	C487	F1H1H104B055	0.1uF 50V	1	
	C490	F1H1H104B055	0.1uF 50V	1	
	C492	F1H1H333B055	0.033uF 50V	1	
	C493	F1H1H104B055	0.1uF 50V	1	
	C496	F2A1E331B423	330uF 25V	1	
	C497	F1H1H104B055	0.1uF 50V	1	
	C498	F1H1H333B055	0.033uF 50V	1	
	C501	F1H1H104B055	0.1uF 50V	1	
	C502	F1H1H104B055	0.1uF 50V	1	
	C505	F2A1E331B423	330uF 25V	1	
	C507	F1H1H333B055	0.033uF 50V	1	
	C508	F1H1H104B055	0.1uF 50V	1	
	C509	F1H1H104B055	0.1uF 50V	1	
	C510	F1H1H333B055	0.033uF 50V	1	
	C512	F1H1H104B055	0.1uF 50V	1	
	C514	F1H1H104B055	0.1uF 50V	1	
	C519	F2A1E331B423	330uF 25V	1	
	C522	F1H1H104B055	0.1uF 50V	1	
	C523	F1H1H104B055	0.1uF 50V	1	
	C526	F1H1H104B055	0.1uF 50V	1	
	C527	F1H1H333B055	0.033uF 50V	1	
	C528	F1H1H104B055	0.1uF 50V	1	
	C529	F1H1H104B055	0.1uF 50V	1	
	C530	F1H1H333B055	0.033uF 50V	1	
	C533	F2A1E331B423	330uF 25V	1	
	C537	F1H1H104B055	0.1uF 50V	1	
	C540	F1H1H104B055	0.1uF 50V	1	
	C546	F1H1H104B055	0.1uF 50V	1	
	C547	F1H1H333B055	0.033uF 50V	1	
	C548	F2A1C100A207	10uF 16V	1	
	C550	F1H1H333B055	0.033uF 50V	1	
	C551	F1H1H104B055	0.1uF 50V	1	
	C554	F2A1E331B423	330uF 25V	1	

Safety	Ref. No.	Part No.	Part Name & Description	Qty	Remarks
	C558	F1H1H104B055	0.1uF 50V	1	
	C559	F1H1H104B055	0.1uF 50V	1	
	C566	F1H1H102B047	1000pF 50V	1	
	C567	F1H1H102B047	1000pF 50V	1	
	C574	F1H1H104B055	0.1uF 50V	1	
	C600	F1H1H102B047	1000pF 50V	1	
	C601	F1H1H220A889	22pF 50V	1	
	C602	F1H1H220A889	22pF 50V	1	
	C603	F1H1A105A036	1uF 10V	1	
	C604	F1H1A105A036	1uF 10V	1	
	C605	F1G1C104A146	0.1uF 16V	1	
	C606	F1G1C104A146	0.1uF 16V	1	
	C607	F2A1C1010033	100uF 16V	1	
	C608	F1H1H104B055	0.1uF 50V	1	
	C609	F1H1H153A885	0.015uF 50V	1	
	C610	F1H1H153A885	0.015uF 50V	1	
	C702	F2A1C100A207	10uF 16V	1	
	C703	F1J1A106A043	10uF 10V	1	
	C704	F1J1A106A043	10uF 10V	1	
	C705	F1J1A106A043	10uF 10V	1	
	C706	F1H1H102B047	1000pF 50V	1	
	C707	F1J1A106A043	10uF 10V	1	
	C708	F2A0J470A013	47uF 6.3V	1	
	C802	F1H1H104B055	0.1uF 50V	1	
	C803	F1H1H104B055	0.1uF 50V	1	
	C804	F1J1H4740002	0.47uF 50V	1	
	C805	F1J1H4740002	0.47uF 50V	1	
	C806	F1J1H4740002	0.47uF 50V	1	
	C807	F1J1H4740002	0.47uF 50V	1	
	C808	F1J1H4740002	0.47uF 50V	1	
	C809	F1J1H4740002	0.47uF 50V	1	
	C903	F1H1H104B055	0.1uF 50V	1	
	C905	F2A0J101A208	100uF 6.3V	1	
	C908	F1J1V1050001	1uF 35V	1	
	C909	F1H1H104B055	0.1uF 50V	1	
	C912	F1H1H103B047	0.01uF 50V	1	
	C913	F2A1H220A216	22uF 50V	1	
	C915	F2A1H220A216	22uF 50V	1	
	C931	F1J1A106A043	10uF 10V	1	
	C2823	F1H1H101B052	100pF 50V	1	
	C2900	F2A1C330B453	33uF 16V	1	
	C2902	F1H1H562B047	5600pF 50V	1	
	C2903	F2A1V3300058	33uF 35V	1	
	C2906	F2A1C821B459	820uF 16V	1	
	C2907	F2A1E101B416	100uF 25V	1	
	C2908	F1H1H104B055	0.1uF 50V	1	
	C2912	F2A0J101B034	100uF 6.3V	1	
	C3958	F1G1A1040006	0.1uF 10V	1	
	C4014	F2A1A1010024	100uF 10V	1	
	C4015	F2A1A1010024	100uF 10V	1	
	C4016	F2A1A1010024	100uF 10V	1	
	C4027	F1H1H101A889	100pF 50V	1	
	C4028	F1H1H101A889	100pF 50V	1	
	C4029	F1H1H101A889	100pF 50V	1	
⚠	C5702	F0CAF104A105	0.1uF	1	
⚠	C5703	F0CAF104A105	0.1uF	1	
⚠	C5704	F1BAF1020020	1000pF	1	
⚠	C5705	F1BAF1020020	1000pF	1	
⚠	C5706	F1BAF1020020	1000pF	1	
	C5709	F2B2G1810020	180uF 400V	1	
	C5711	F0C2J1020001	1000pF 630V	1	
	C5714	F1H1E224A068	0.22uF 25V	1	
	C5715	F1H1H104B055	0.1uF 50V	1	
	C5716	F2A1H4R70070	4.7uF 50V	1	
	C5717	F1H1E224A068	0.22uF 25V	1	
	C5718	F1H1C104A179	0.1uF 16V	1	
	C5719	F1H1C224A178	0.22uF 16V	1	
	C5720	F1H1E103A161	0.01uF 25V	1	
	C5721	F1H1H221B047	220pF 50V	1	
	C5724	F2A1E1020114	1000uF 25V	1	
	C5725	F1H1H104B055	0.1uF 50V	1	
	C5726	F1H1E334A068	0.33uF 25V	1	
	C5727	F1H1H102B047	1000pF 50V	1	

Safety	Ref. No.	Part No.	Part Name & Description	Qty	Remarks
	C5729	F1H1H103B047	0.01uF 50V	1	
	C5843	F1H1C105A095	1uF 50V	1	
	C8001	EEE0GA331WP	330uF 4V	1	
	C8002	F1G1A1040006	0.1uF 10V	1	
	C8003	F1G1A1040006	0.1uF 10V	1	
	C8006	F1G1H101A834	100pF 50V	1	
	C8007	F1G1A1040006	0.1uF 10V	1	
	C8008	F1G1A1040006	0.1uF 10V	1	
	C8009	F1G1A1040006	0.1uF 10V	1	
	C8010	F1G1A1040006	0.1uF 10V	1	
	C8011	F2G0J2210020	220uF 6.3V	1	
	C8012	F1G1A1040006	0.1uF 10V	1	
	C8013	F1G1A1040006	0.1uF 10V	1	
	C8014	F1G1A1040006	0.1uF 10V	1	
	C8016	F1G1A1040006	0.1uF 10V	1	
	C8017	F1G1A1040006	0.1uF 10V	1	
	C8018	F1G1A1040006	0.1uF 10V	1	
	C8019	F1G1A1040006	0.1uF 10V	1	
	C8020	F1G1A1040006	0.1uF 10V	1	
	C8021	F1G1A1040006	0.1uF 10V	1	
	C8022	F1G1A1040006	0.1uF 10V	1	
	C8023	F1G1A1040006	0.1uF 10V	1	
	C8024	F1G1H1020008	1000pF 50V	1	
	C8027	F1G1A1040006	0.1uF 10V	1	
	C8028	F1G1C103A146	0.01uF 16V	1	
	C8029	F1G1H1020008	1000pF 50V	1	
	C8030	F2G0J330A031	33uF 6.3V	1	
	C8032	F1G1A1040006	0.1uF 10V	1	
	C8033	F1G1A1040006	0.1uF 10V	1	
	C8034	F1G1A1040006	0.1uF 10V	1	
	C8051	F1H0J105A051	1uF 6.3V	1	
	C8052	F1G1A1040006	0.1uF 10V	1	
	C8053	F1G1A1040006	0.1uF 10V	1	
	C8054	F1G1H221A834	220pF 50V	1	
	C8055	F1H0J105A051	1uF 6.3V	1	
	C8056	F1G1H222A830	2200pF 50V	1	
	C8057	F1H0J105A051	1uF 6.3V	1	
	C8058	F2G0J101A031	100uF 6.3V	1	
	C8101	F1H0J4750005	4.7uF 6.3V	1	
	C8111	F1J1A106A043	10uF 10V	1	
	C8112	F1H0J105A051	1uF 6.3V	1	
	C8113	F1H0J4750005	4.7uF 6.3V	1	
	C8121	F1G1A1040006	0.1uF 10V	1	
	C8151	F1H0J4750005	4.7uF 6.3V	1	
	C8222	F1G1C273A146	0.027uF 16V	1	
	C8226	F1G1C273A146	0.027uF 16V	1	
	C8228	F1G1H1020008	1000pF 50V	1	
	C8230	F1G1H1020008	1000pF 50V	1	
	C8251	F2G0J101A031	100uF 6.3V	1	
	C8252	F2G1C4700061	47uF 16V	1	
	C8256	F1G1A1040006	0.1uF 10V	1	
	C8263	F1G1A1040006	0.1uF 10V	1	
	C8264	F1G1A1040006	0.1uF 10V	1	
	C8301	F2G0J101A031	100uF 6.3V	1	
	C8302	F2G0J101A031	100uF 6.3V	1	
	C8401	F2G0J2210020	220uF 6.3V	1	
	C8511	F1G1H1020008	1000pF 50V	1	
	C8512	F1G1H1020008	1000pF 50V	1	
	C8528	F1H0J105A051	1uF 6.3V	1	
	C8530	F1G1A1040006	0.1uF 10V	1	
	C8533	F1G1A1040006	0.1uF 10V	1	
	C8551	F1G1A1040006	0.1uF 10V	1	
	C8553	F2G0J2210020	220uF 6.3V	1	
	C8561	F1G1A1040006	0.1uF 10V	1	
	C8563	F2G0J2210020	220uF 6.3V	1	
	C8566	F2G0J101A031	100uF 6.3V	1	
	C8606	F1G1A1040006	0.1uF 10V	1	
	C8621	F1G1H100A834	10pF 50V	1	
	C8622	F1G1H8R0A833	8pF 50V	1	
	C8651	F1G1A1040006	0.1uF 10V	1	
	C8652	F1G1A1040006	0.1uF 10V	1	
	C9006	F1G1A1040006	0.1uF 10V	1	
	X8301	F1H1H102B047	1000pF 50V	1	

Safety	Ref. No.	Part No.	Part Name & Description	Qty	Remarks
	FL8101	F1H0J1050018	1uF 6.3V	1	
	FL8102	F1H0J1050018	1uF 6.3V	1	
	FL8103	F1H0J1050018	1uF 6.3V	1	
	FL8104	F1J1E1040022	0.1uF 25V	1	
			SERVICE FIXTURE & TOOLS		
	SFT1	RFKZXH150PK2	50P FFC (MAIN TO BACKEND)	1	

MMH1204