

# Service Manual

26 inch Class 720p LCD HDTV

Model No. **TC-L26X1**

LH90 Chassis

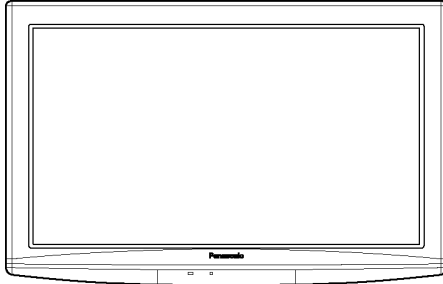

## **WARNING**

This service information is designed for experienced repair technicians only and is not designed for use by the general public. It does not contain warnings or cautions to advise non-technical individuals of potential dangers in attempting to service a product. Products powered by electricity should be serviced or repaired only by experienced professional technicians. Any attempt to service or repair the product or products dealt with in this service information by anyone else could result in serious injury or death.

## **IMPORTANT SAFETY NOTICE**

There are special components used in this equipment which are important for safety. These parts are marked by  in the Schematic Diagrams, Circuit Board Diagrams, Exploded Views and Replacement Parts List. It is essential that these critical parts should be replaced with manufacturer's specified parts to prevent shock, fire or other hazards. Do not modify the original design without permission of manufacturer.

# TABLE OF CONTENTS

	PAGE		PAGE
<b>1 Safety Precautions</b> .....	<b>3</b>	11.12. V-Board Schematic Diagram .....	40
1.1. General Guidelines .....	3	<b>12 Printed Circuit Board</b> .....	<b>41</b>
<b>2 Warning</b> .....	<b>4</b>	12.1. A-Board .....	41
2.1. Prevention of Electrostatic Discharge (ESD) to Electrostatically Sensitive (ES) Devices .....	4	12.2. V-Board .....	44
2.2. About lead free solder (PbF) .....	5	<b>13 Exploded View and Replacement Parts List</b> .....	<b>45</b>
<b>3 Service Navigation</b> .....	<b>6</b>	13.1. Exploded View and Mechanical Replacement Parts List .....	45
3.1. Service Hint .....	6	13.2. Electrical Replacement Parts List .....	49
3.2. Applicable signals .....	6		
<b>4 Specifications</b> .....	<b>7</b>		
<b>5 Service Mode</b> .....	<b>8</b>		
5.1. How to enter into Service Mode .....	8		
5.2. SRV-TOOL .....	9		
5.3. Hotel mode .....	10		
<b>6 Troubleshooting Guide</b> .....	<b>11</b>		
6.1. Check of the IIC bus lines .....	11		
6.2. Power LED Blinking timing chart .....	12		
6.3. No Power .....	13		
<b>7 Disassembly and Assembly Instructions</b> .....	<b>14</b>		
7.1. Pedestal .....	14		
7.2. Rear cover .....	14		
7.3. AC cord .....	14		
7.4. P-Board .....	14		
7.5. Side AV bracket .....	15		
7.6. A-Board .....	15		
7.7. Control panel .....	15		
7.8. Speaker .....	15		
7.9. A PCB Chassis frame .....	16		
7.10. P PCB plastic frame .....	16		
7.11. VESA metal .....	16		
7.12. LCD MTG .....	16		
7.13. LCD Panel .....	17		
7.14. V-Board .....	17		
7.15. EMI processing .....	18		
<b>8 Measurements and Adjustments</b> .....	<b>21</b>		
8.1. Voltage chart of A-board .....	21		
8.2. Picture level adjustment (RF) .....	21		
8.3. Picture level adjustment (VIDEO) .....	22		
8.4. Picture level adjustment (YUV) .....	22		
<b>9 Block Diagram</b> .....	<b>23</b>		
9.1. Main Block Diagram .....	23		
9.2. Block (1/2) Diagram .....	24		
9.3. Block (2/2) Diagram .....	25		
<b>10 Wiring Connection Diagram</b> .....	<b>27</b>		
10.1. Caution statement .....	27		
10.2. Wiring .....	27		
<b>11 Schematic Diagram</b> .....	<b>29</b>		
11.1. Schematic Diagram Notes .....	29		
11.2. A-Board (1/10) Schematic Diagram .....	30		
11.3. A-Board (2/10) Schematic Diagram .....	31		
11.4. A-Board (3/10) Schematic Diagram .....	32		
11.5. A-Board (4/10) Schematic Diagram .....	33		
11.6. A-Board (5/10) Schematic Diagram .....	34		
11.7. A-Board (6/10) Schematic Diagram .....	35		
11.8. A-Board (7/10) Schematic Diagram .....	36		
11.9. A-Board (8/10) Schematic Diagram .....	37		
11.10. A-Board (9/10) Schematic Diagram .....	38		
11.11. A-Board (10/10) Schematic Diagram .....	39		

# 1 Safety Precautions

## 1.1. General Guidelines

1. When servicing, observe the original lead dress. If a short circuit is found, replace all parts which have been overheated or damaged by the short circuit.
2. After servicing, see to it that all the protective devices such as insulation barriers, insulation papers shields are properly installed.
3. After servicing, make the following leakage current checks to prevent the customer from being exposed to shock hazards.
4. When conducting repairs and servicing, do not attempt to modify the equipment, its parts or its materials.
5. When wiring units (with cables, flexible cables or lead wires) are supplied as repair parts and only one wire or some of the wires have been broken or disconnected, do not attempt to repair or re-wire the units. Replace the entire wiring unit instead.
6. When conducting repairs and servicing, do not twist the Faston connectors but plug them straight in or unplug them straight out.

### 1.1.1. Leakage Current Cold Check

1. Unplug the AC cord and connect a jumper between the two prongs on the plug.
2. Measure the resistance value, with an ohmmeter, between the jumpered AC plug and each exposed metallic cabinet part on the equipment such as screwheads, connectors, control shafts, etc. When the exposed metallic part has a return path to the chassis, the reading should be 100 Mohm and over.

When the exposed metal does not have a return path to the chassis, the reading must be  $\infty$ .

### 1.1.2. Leakage Current Hot Check (See Figure 1.)

1. Plug the AC cord directly into the AC outlet. Do not use an isolation transformer for this check.
2. Connect a 1.5kohm, 10 watts resistor, in parallel with a 0.15 $\mu$ F capacitors, between each exposed metallic part on the set and a good earth ground such as a water pipe, as shown in Figure 1.
3. Use an AC voltmeter, with 1000 ohms/volt or more sensitivity, to measure the potential across the resistor.
4. Check each exposed metallic part, and measure the voltage at each point.
5. Reverse the AC plug in the AC outlet and repeat each of the above measurements.
6. The potential at any point should not exceed 0.75 volts RMS. A leakage current tester (Simpson Model 229 or equivalent) may be used to make the hot checks, leakage current must not exceed 1/2 milliamp. In case a measurement is outside of the limits specified, there is a possibility of a shock hazard, and the equipment should be repaired and rechecked before it is returned to the customer.

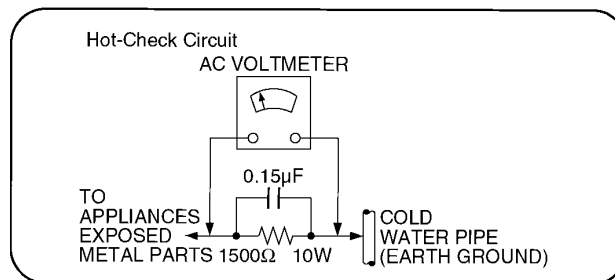

Figure 1

## 2 Warning

### 2.1. Prevention of Electrostatic Discharge (ESD) to Electrostatically Sensitive (ES) Devices

Some semiconductor (solid state) devices can be damaged easily by static electricity. Such components commonly are called Electrostatically Sensitive (ES) Devices. Examples of typical ES devices are integrated circuits and some field-effect transistors and semiconductor [chip] components. The following techniques should be used to help reduce the incidence of component damage caused by electrostatic discharge (ESD).

1. Immediately before handling any semiconductor component or semiconductor-equipped assembly, drain off any ESD on your body by touching a known earth ground. Alternatively, obtain and wear a commercially available discharging ESD wrist strap, which should be removed for potential shock reasons prior to applying power to the unit under test.
2. After removing an electrical assembly equipped with ES devices, place the assembly on a conductive surface such as aluminum foil, to prevent electrostatic charge buildup or exposure of the assembly.
3. Use only a grounded-tip soldering iron to solder or unsolder ES devices.
4. Use only an anti-static solder removal device. Some solder removal devices not classified as [anti-static (ESD protected)] can generate electrical charge sufficient to damage ES devices.
5. Do not use freon-propelled chemicals. These can generate electrical charges sufficient to damage ES devices.
6. Do not remove a replacement ES device from its protective package until immediately before you are ready to install it. (Most replacement ES devices are packaged with leads electrically shorted together by conductive foam, aluminum foil or comparable conductive material).
7. Immediately before removing the protective material from the leads of a replacement ES device, touch the protective material to the chassis or circuit assembly into which the device will be installed.

#### **Caution**

Be sure no power is applied to the chassis or circuit, and observe all other safety precautions.

8. Minimize bodily motions when handling unpackaged replacement ES devices. (Otherwise ham less motion such as the brushing together of your clothes fabric or the lifting of your foot from a carpeted floor can generate static electricity (ESD) sufficient to damage an ES device).

## 2.2. About lead free solder (PbF)

**Note:** Lead is listed as (Pb) in the periodic table of elements.

In the information below, Pb will refer to Lead solder, and PbF will refer to Lead Free Solder.

The Lead Free Solder used in our manufacturing process and discussed below is (Sn+Ag+Cu).

That is Tin (Sn), Silver (Ag) and Copper (Cu) although other types are available.

This model uses Pb Free solder in it's manufacture due to environmental conservation issues. For service and repair work, we'd suggest the use of Pb free solder as well, although Pb solder may be used.

PCBs manufactured using lead free solder will have the PbF within a leaf Symbol **PbF** stamped on the back of PCB.

### Caution

- Pb free solder has a higher melting point than standard solder. Typically the melting point is 50 ~ 70 °F (30~40 °C) higher. Please use a high temperature soldering iron and set it to 700 ± 20 °F (370 ± 10 °C).
- Pb free solder will tend to splash when heated too high (about 1100 °F or 600 °C).  
If you must use Pb solder, please completely remove all of the Pb free solder on the pins or solder area before applying Pb solder. If this is not practical, be sure to heat the Pb free solder until it melts, before applying Pb solder.
- After applying PbF solder to double layered boards, please check the component side for excess solder which may flow onto the opposite side. (see figure below)

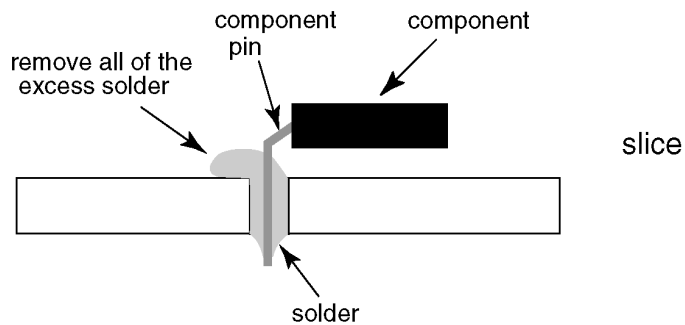

### Suggested Pb free solder

There are several kinds of Pb free solder available for purchase. This product uses Sn+Ag+Cu (tin, silver, copper) solder. However, Sn+Cu (tin, copper), Sn+Zn+Bi (tin, zinc, bismuth) solder can also be used.

0.3mm X 100g	0.6mm X 100g	1.0mm X 100g

### 3 Service Navigation

#### 3.1. Service Hint

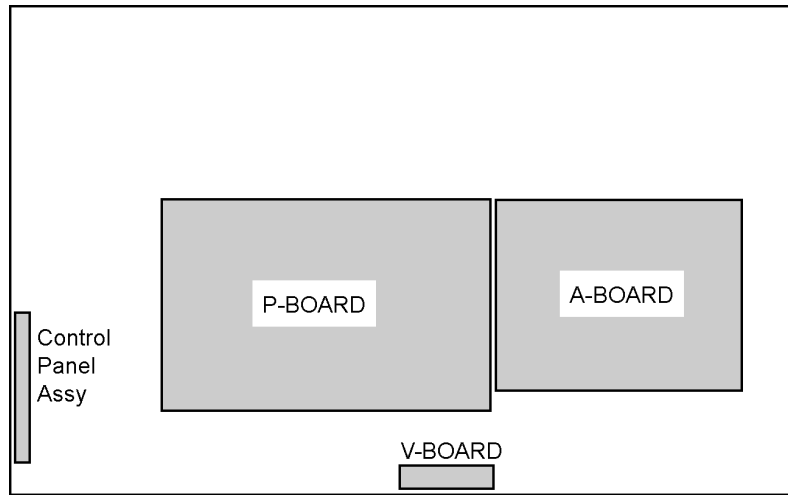

Board Name	Function
A-Board	Rear Terminal, AV Switch, MCU, Audio & Video Processor, LVDS, Tuner
V-Board	Remote Receiver, LED
P-Board	Power (AC/DC), DC-DC Non-serviceable P-Board should be exchanged for service.
Control Panel Assy	Control Button, Power switch Non-serviceable Control Panel Assy should be exchanged for service.

#### 3.2. Applicable signals

##### Input signal that can be displayed

\* Mark: Applicable input signal for Component (Y, P<sub>B</sub>, P<sub>R</sub>), HDMI and PC

	horizontal frequency (kHz)	vertical frequency (Hz)	COMPONENT	HDMI	PC
525 (480) / 60i	15.73	59.94	*	*	
525 (480) /60p	31.47	59.94	*	*	
750 (720) /60p	45.00	59.94	*	*	
1,125 (1,080) /60i	33.75	59.94	*	*	
640 × 400 @70	31.47	70.08			*
640 × 480 @60	31.47	59.94			*
Macintosh13 inch (640 × 480)	35.00	66.67			*
640 × 480 @75	37.50	75.00			*
852 × 480 @60	31.47	59.94			*
800 × 600 @60	37.88	60.32			*
800 × 600 @75	46.88	75.00			*
800 × 600 @85	53.67	85.08			*
Macintosh16 inch (832 × 624)	49.73	74.55			*
1,024 × 768 @60	48.36	60.00			*
1,024 × 768 @70	56.48	70.07			*
1,024 × 768 @75	60.02	75.03			*
1,024 × 768 @85	68.68	85.00			*
Macintosh 21 inch (1,152 × 870)	68.68	75.06			*
1,280 × 768 @60	47.70	60.00			*
1,280 × 1,024 @60	63.98	60.02			*
1,366 × 768 @60	48.36	60.00			*

##### Note:

- Signals other than above may not be displayed properly.
- The above signals are reformatted for optimal viewing on your display.

# 4 Specifications

<b>Power Source</b>	AC 110-127 V, 60 Hz	
<b>Power Consumption</b>		
<b>Maximum</b>	79 W	
<b>Standby Condition</b>	0.6 W	
<b>Display panel</b>		
<b>Aspect Ratio</b>	16:9	
<b>Visible screen size</b>	26 inch class (26.0 inches measured diagonally)	
<b>(W × H × Diagonal)</b>	22.7 inch × 12.8 inch × 26.0 inch (576 mm × 324 mm × 661 mm)	
<b>(No. of pixels)</b>	1,049,088 (1,366 (W) × 768 (H)) [4,098 × 768 dots]	
<b>Sound</b>		
<b>Speaker</b>	1-way 2 speakers slim under SP System	
<b>Audio Output</b>	10 W [5 W + 5 W] ( 10 % THD )	
<b>PC signals</b>	VGA, SVGA, XGA, WXGA, SXGA	
	Horizontal scanning frequency 31 - 69 kHz	
	Vertical scanning frequency 59 - 86 Hz	
<b>Channel Capability- ATSC/NTSC (Digital/Analog)</b>	VHF/ UHF: 2 - 69, CATV: 1 - 135	
<b>Operating Conditions</b>	Temperature:	32 °F - 95 °F (0 °C - 35°C)
	Humidity:	20 % - 80 % RH (non-condensing)
<b>Connection Terminals</b>		
<b>VIDEO IN 1</b>	VIDEO:	RCA PIN Type × 1 1.0 V [p-p] (75 Ω)
	AUDIO L - R:	RCA PIN Type × 2 0.5 V [rms]
<b>VIDEO IN 2</b>	VIDEO:	RCA PIN Type × 1 1.0 V[p-p] (75 Ω)
	S VIDEO:	Mini DIN 4-pin Y: 1.0 V[p-p] (75 Ω) C: 0.286 V [p-p] (75 Ω)
	AUDIO L - R:	RCA PIN Type × 2 0.5 V [rms]
<b>COMPONENT IN 1</b>	Y:	1.0 V [p-p] (including synchronization)
	PB, PR:	±0.35 V [p-p]
	AUDIO L-R:	RCA PIN Type × 2 0.5 V [rms]
<b>HDMI 1-2</b>	TYPE A Connector × 2.	
	● This TV supports [HDAVI Control 4] function.	
<b>PC</b>	D-SUB 15PIN:	R,G,B / 0.7 V [p-p] (75 Ω) HD, VD / 1.0 - 5.0 V [p-p] (high impedance)
<b>Card slot</b>	SD CARD slot × 1	
<b>DIGITAL AUDIO OUT</b>	PCM / Dolby Digital, Fiber Optic	
<b>FEATURES</b>	CLOSED CAPTION, V-Chip	
	HDMI (HDAVI Control 4)	
	Vesa compatible, Photo viewer	
<b>Dimensions (W × H × D)</b>		
<b>Including TV stand</b>	26.2 inch × 18.7 inch × 8.6 inch (664 mm × 474 mm × 217 mm)	
<b>TV Set only</b>	26.2 inch × 17.1 inch × 4.7 inch (664 mm × 434 mm × 118 mm)	
<b>Mass</b>		
<b>Including TV stand</b>	23.2 lb. (10.5 kg) NET	
<b>TV Set only</b>	19.9 lb. (9.0 kg) NET	

**Note**

Design and Specifications are subject to change without notice. Mass and Dimensions shown are approximate.

# 5 Service Mode

## 5.1. How to enter into Service Mode

While pressing [VOLUME (-)] button of the main unit, press [INFO] button of the remote control three times within 2 seconds.

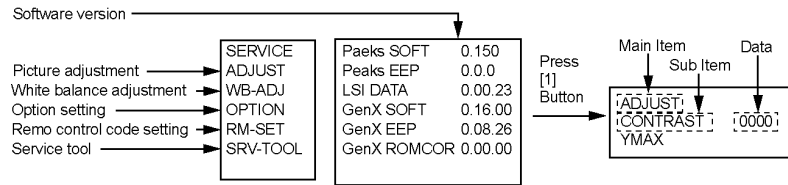

### 5.1.1. Key command

- [1] button...Main items Selection in forward direction
- [2] button...Main items Selection in reverse direction
- [3] button...Sub items Selection in forward direction
- [4] button...Sub items Selection in reverse direction
- [VOL] button...Value of sub items change in forward direction (+), in reverse direction (-)

### 5.1.2. Contents of adjustment mode

- Value is shown as a hexadecimal number.
- Preset value differs depending on models.
- After entering the adjustment mode, take note of the value in each item before starting adjustment.

Main item	Sub item	Sample Data	Remark
ADJUST	CONTRAST	000	
	COLOR	4C	
	TINT	00	
	SUB-BRT	808	
	BACKLGT	22E	
	B-Y-G	34	
	R-Y-A	00	
WB-ADJ	R-GAIN	F7	
	G-GAIN	FB	
	B-GAIN	DB	
	R-CENT	82	
	G-CENT	80	
	B-CENT	86	
OPTION	Boot	ROM	Factory Preset.
	STBY-SET	00	
	EMERGENCY	ON	
	CLK MODE	00	
	CLOCK	0E4	
RM-SET		00	Fixed.
SRV-TOOL		00	See next.

### 5.1.3. How to exit

Switch off the power with the [POWER] button on the main unit or the [POWER] button on the remote control.

## 5.2. SRV-TOOL

### 5.2.1. How to access

1. Select [SRV-TOOL] in Service Mode.
2. Press [OK] button on the remote control.

SRV-TOOL		
Display of TD2Microcode version →	TD2Microcode:81c00011	
Display of Flash ROM maker code →	Flash ROM : 1 - 227E	
Display of SOS History →	PTCT : 00 . 00 . 00 . 00 . 00	Time 000040:40 Count 0000049 ← POWER ON TIME/COUNT Press [MUTE] button (3sec)

### 5.2.2. Display of SOS History

SOS History (Number of LED blinking ) indication.

From left side; Last SOS, before Last, three occurrence before, 2nd occurrence after shipment, 1st occurrence after shipment.

This indication except 2nd and 1st occurrence after shipment will be cleared by [Self-check indication and forced to factory shipment setting].

### 5.2.3. POWER ON TIME/COUNT

Note : To display TIME/COUNT menu, highlight position, then press MUTE for 3sec.

Time : Cumulative power on time, indicated hour : minute by decimal

Count : Number of ON times by decimal

Note : This indication will not be cleared by either of the self-checks or any other command.

### 5.2.4. Exit

1. Disconnect the AC cord from wall outlet.

### 5.3. Hotel mode

1. Purpose  
Restrict a function for hotels.
2. Access command to the Hotel mode setup menu  
In order to display the Hotel mode setup menu, please enter the following command (**within 2 second**).  
[TV] : Vol. [Down] + [REMOTE] : INPUT (3 times)

Then, the Hotel mode setup menu is displayed.

#### Hotel Mode

Mode	Off
Input	-
Channel	-
Volume	+ 25
Vol. Max	+ 100
OSD Ctrl	Off
FP Ctrl	Off
Pow Ctrl	Off

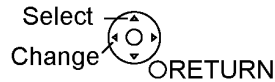

3. To exit the Hotel mode setup menu  
Disconnect AC power cord from wall outlet.
4. Explain the Hotel mode setup menu

item	Function
Mode	Select hotel mode off/on
Input	Select input signal modes. Set the input, when each time power is switched on. Selection: -/RF/Component/HDMI1/HDMI2/Video1/Video2/PC • Off: give priority to a last memory.
Channel	Select channel when input signal is RF. Set the channel, each time power is switched on. Selection: Any channel number or [-]. [-] means the channel when turns off.
Volume	Adjust the volume when each time power is switched on. Range: 0 to 100
Vol. Max	Adjust maximum volume. Range: 0 to 100
OSD Ctrl	Restrict the OSD. Selection: OFF/PATTERN1 • OFF: No restriction • PATTERN1: restriction
FP Ctrl	Select front key conditions. Selection: Off/Pattern1/All • Off: altogether valid. • Pattern1: only input key is valid. • All: altogether invalid.
Pow Ctrl	Select POWER-ON/OFF condition when AC power cord is disconnected and then connected. OFF: The same condition when AC power cord is disconnected. ON: Forced power ON condition.

# 6 Troubleshooting Guide

Use the self-check function to test the unit.

1. Checking the IIC bus lines
2. Power LED Blinking timing

## 6.1. Check of the IIC bus lines

### 6.1.1. How to access

Self-check indication only:

Produce TV reception screen, and while pressing [VOLUME ( - )] button on the main unit, press [OK] button on the remote control for more than 3 seconds.

Self-check indication and forced to factory shipment setting:

Produce TV reception screen, and while pressing [VOLUME ( - )] button on the main unit, press [MENU] button on the remote control for more than 3 seconds.

### 6.1.2. Exit

Disconnect the AC cord from wall outlet.

### 6.1.3. Screen display

SELF CHECK		---- . XXXXXX - XXXXXX
PEAKS	OK	
TUN1	OK	
FE	OK	
Hudson	OK	
MEM2	OK	
MEM3	OK	
MEM4	OK	
Copyright Panasonic Corporation 2009.		

### 6.1.4. Check Point

Confirm the following parts if NG was displayed.

DISPLAY	Ref. No.	Description	P.C.B.
PEAKS	IC8001	PEAKS LITE 2P	A-Board
TUN1	TU8300	TUNER	A-Board
FE	IC8300	FRONT END	A-Board
Hudson	IC4003	Hudson2	A-Board
MEM2	IC8503	EEPROM	A-Board
MEM3	IC4004	EEPROM	A-Board
MEM4	IC4504	EEPROM	A-Board

## 6.2. Power LED Blinking timing chart

1. Subject

Information of LED Flashing timing chart.

2. Contents

When an abnormality has occurred the unit, the protection circuit operates and reset to the stand by mode. At this time, the defective block can be identified by the number of blinks of the Power LED on the front panel of the unit.

Blinking Times	Blinking timing	Contents	Check point
1	<p>Once                      3 sec</p> <p>Light No Light</p>	INVERTER SOS	LCD PANEL
3		SOS SUB 1.2V, 1.8V, 3.3V DTV 12V/TUNER 6V/P17V	A-Board P-Board
4		DTV 12V	P-Board
6		SUB 5V	A-Board
9		P17V	A-Board P-Board
13		EMERGENCY SOS (Communication Error between IC8001 and IC4003.)	A-Board

### 6.3. No Power

First check point

There are following 2 states of No Power indication by power LED.

1. No lit
2. Red is lit then turns red blinking a few seconds later. (See 6.2.)

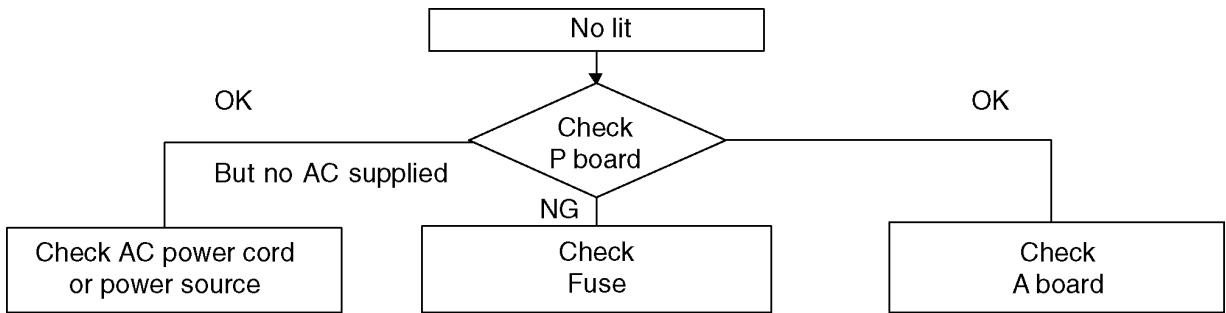

# 7 Disassembly and Assembly Instructions

## 7.1. Pedestal

1. Lay down the unit so that the rear cover faces upward.
2. Remove the 4 screws.
3. Remove the pedestal.

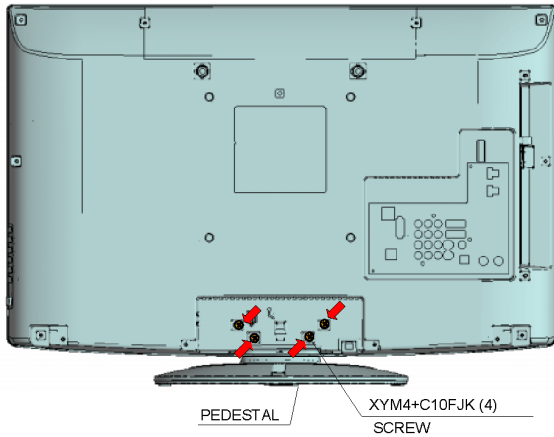

## 7.2. Rear cover

1. Remove the 15 screws (A).
2. Remove the 2 screws (B),
3. Remove the rear cover.

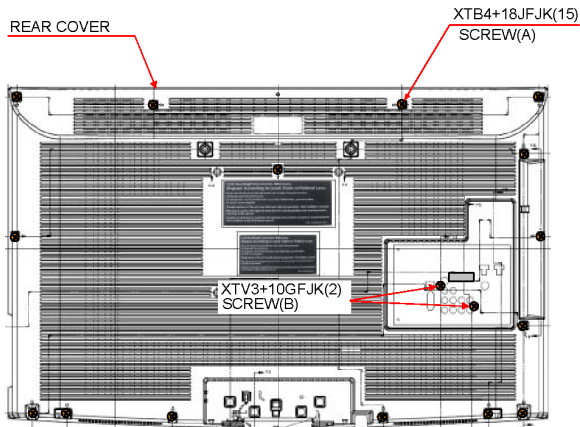

## 7.3. AC cord

1. Remove the screw and Remove the AC cord bracket.
2. Remove the bushing of the AC cord from the AC cord bracket.
3. Disconnect the connector (P1) of AC cord.

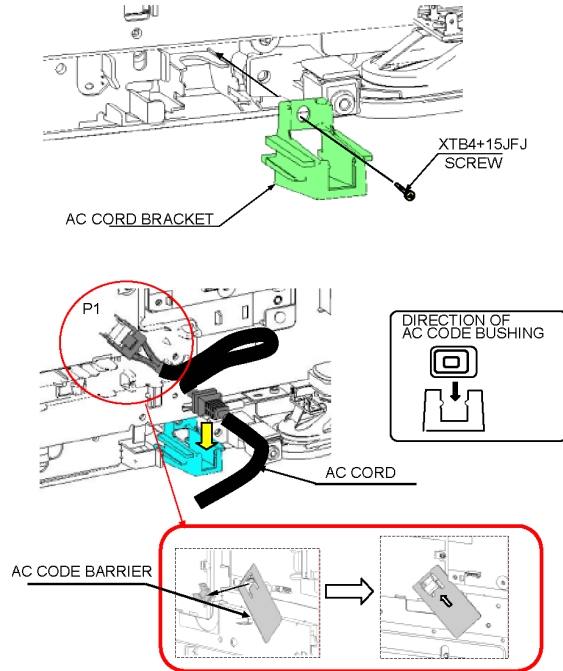

## 7.4. P-Board

1. Remove the 5 screws.
2. Disconnect the connectors (P1, P2, P3, P4, P5, P6).
3. Remove the P-Board.

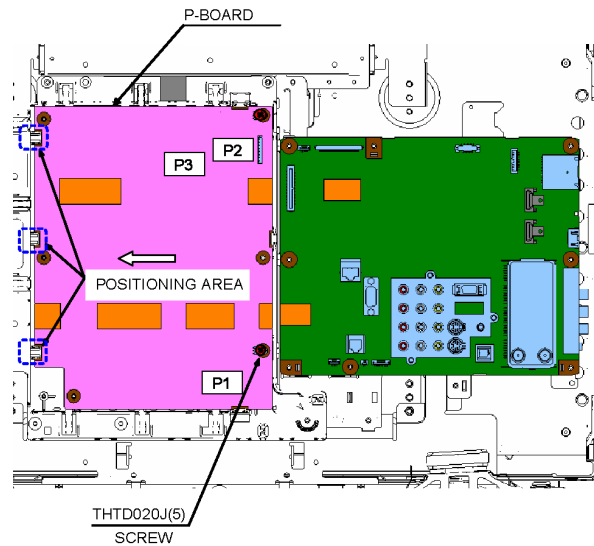

### 7.5. Side AV bracket

1. Remove the 1 screw (C).
2. Remove the 1 screw (D).
3. Remove the side AV bracket.

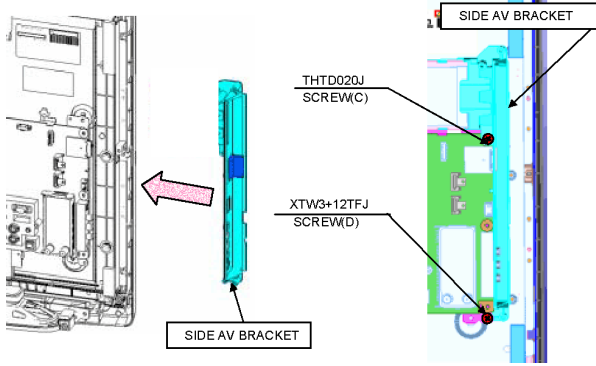

### 7.6. A-Board

1. Remove the 7 screws.
2. Disconnect the connector (A02, A03, A10, A11, A15, A20).
3. Remove the A-Board.

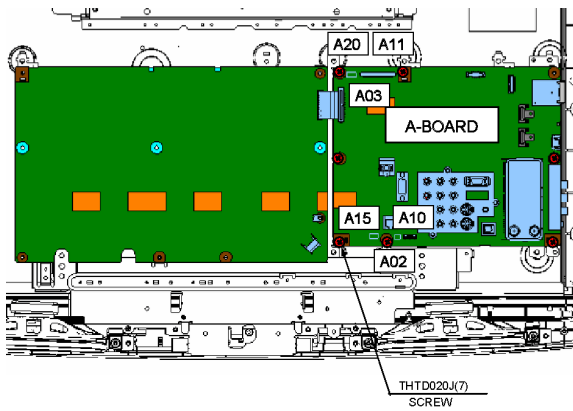

### 7.7. Control panel

1. Disconnect the connector (K1).
2. Remove the 2 screws.
3. Remove the control panel.

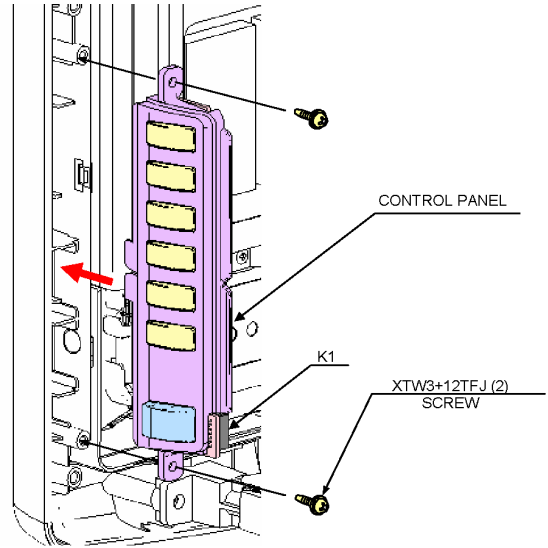

### 7.8. Speaker

1. Remove the 4 screws.
2. Remove the speaker.

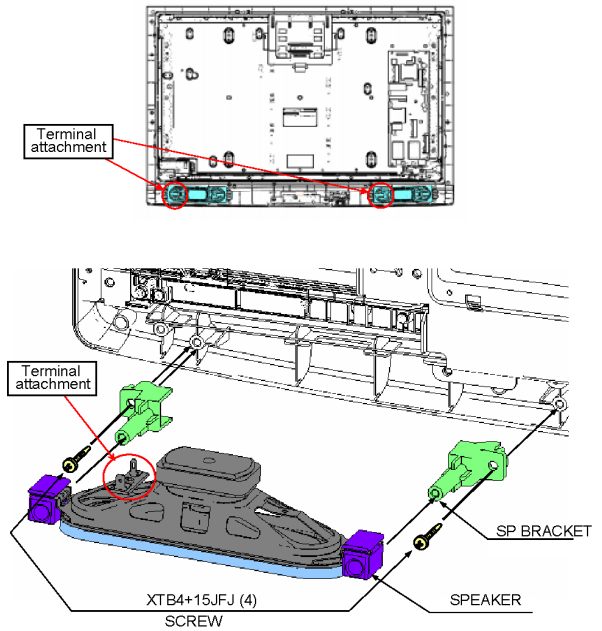

### 7.9. A PCB Chassis frame

1. Remove the 3 screws.
2. Remove the A PCB Chassis frame.

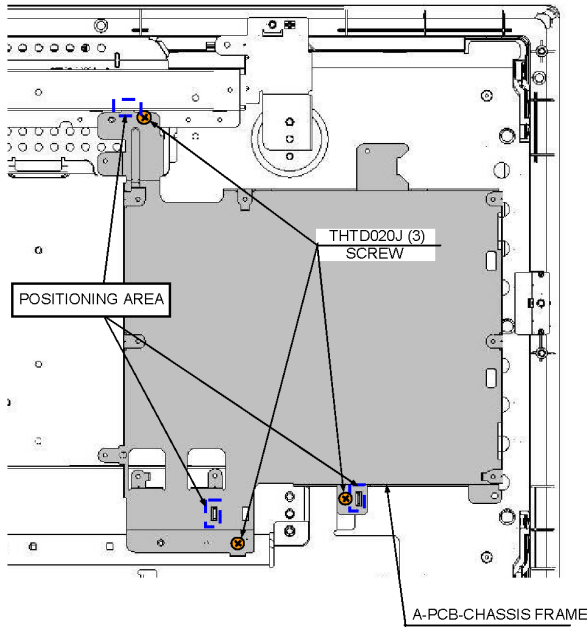

### 7.11. VESA metal

1. Remove the 4 screws (E).
2. Remove the 4 screws (F).
3. Remove the VESA metal.

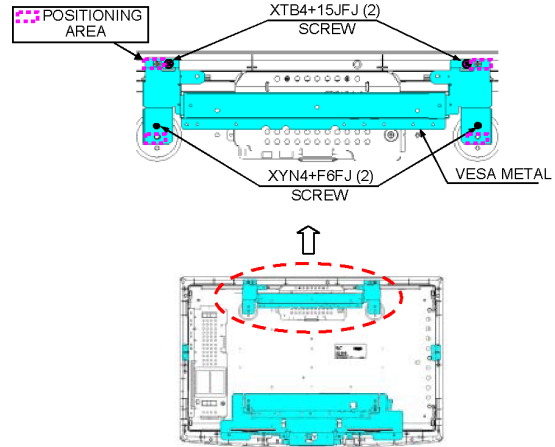

### 7.12. LCD MTG

1. Remove the 4 screws (G).
2. Remove the 4 screws (H).
3. Remove the LCD BTM MTG.

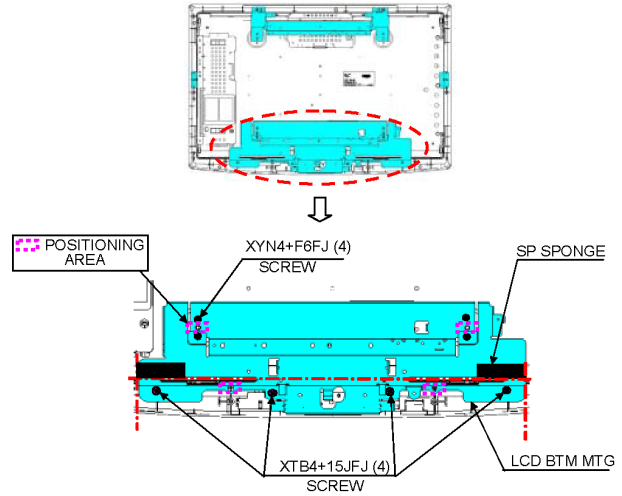

### 7.10. P PCB plastic frame

1. Remove the 4 screws.
2. Remove the P PCB plastic frame.

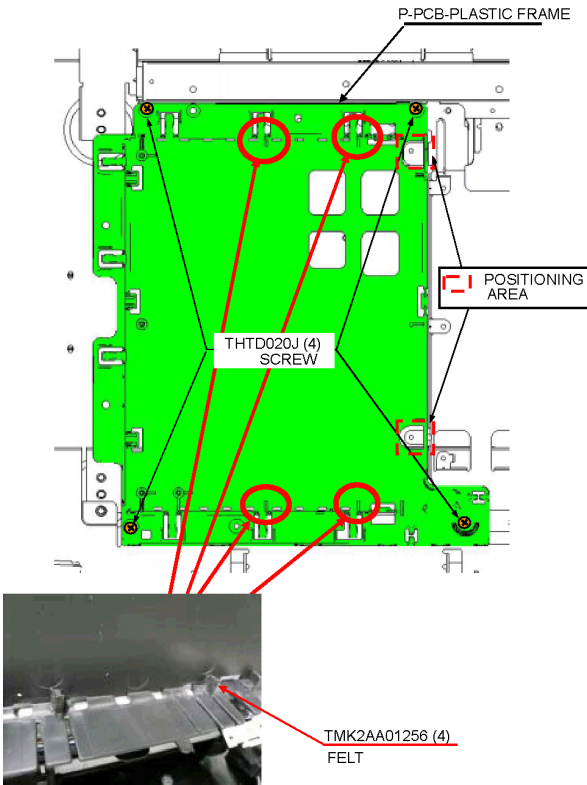

### 7.13. LCD Panel

1. Remove the 2 screws.
2. Remove the LCD panel and LCD side MTG.

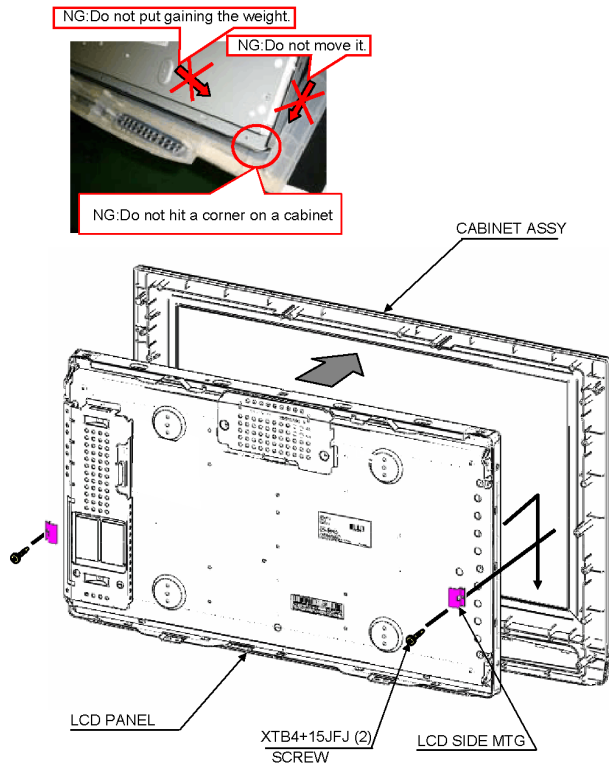

### 7.14. V-Board

1. Remove the 1 screw.
2. Disconnect the connector (V10).
3. Remove the V-Board.

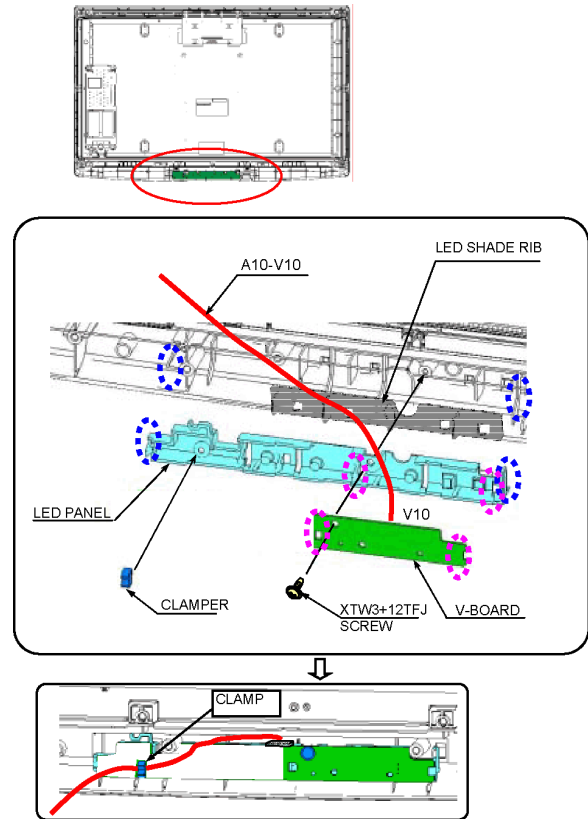

## 7.15. EMI processing

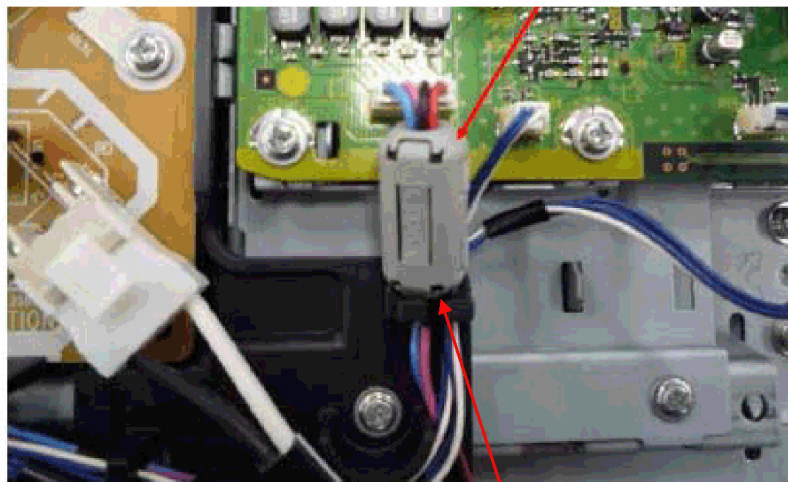
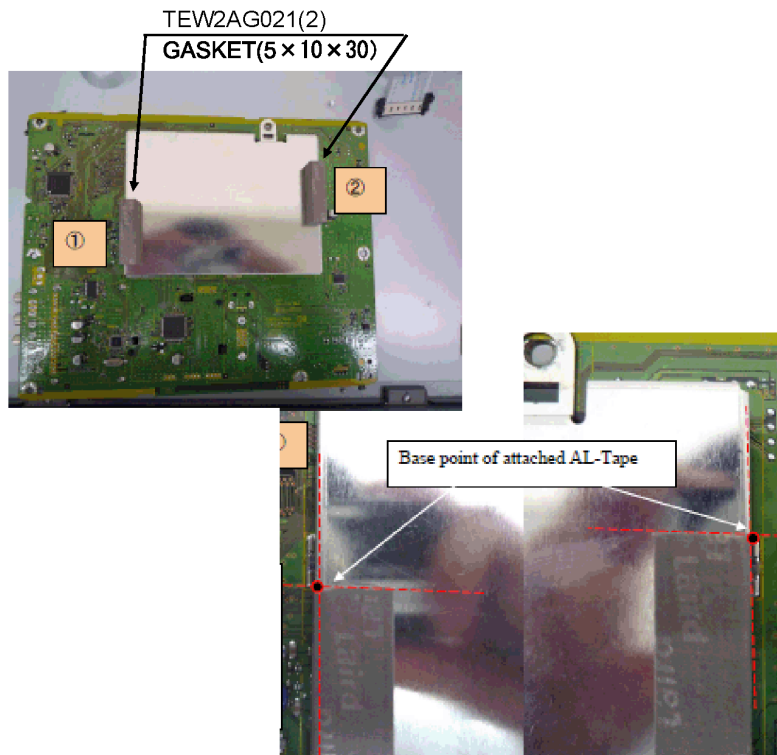

J0KG0000001  
Ferrite-core (For SP-lead)

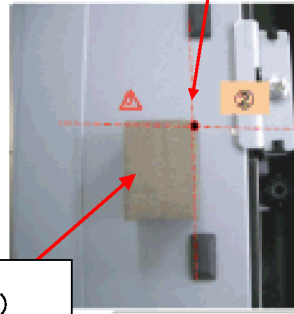
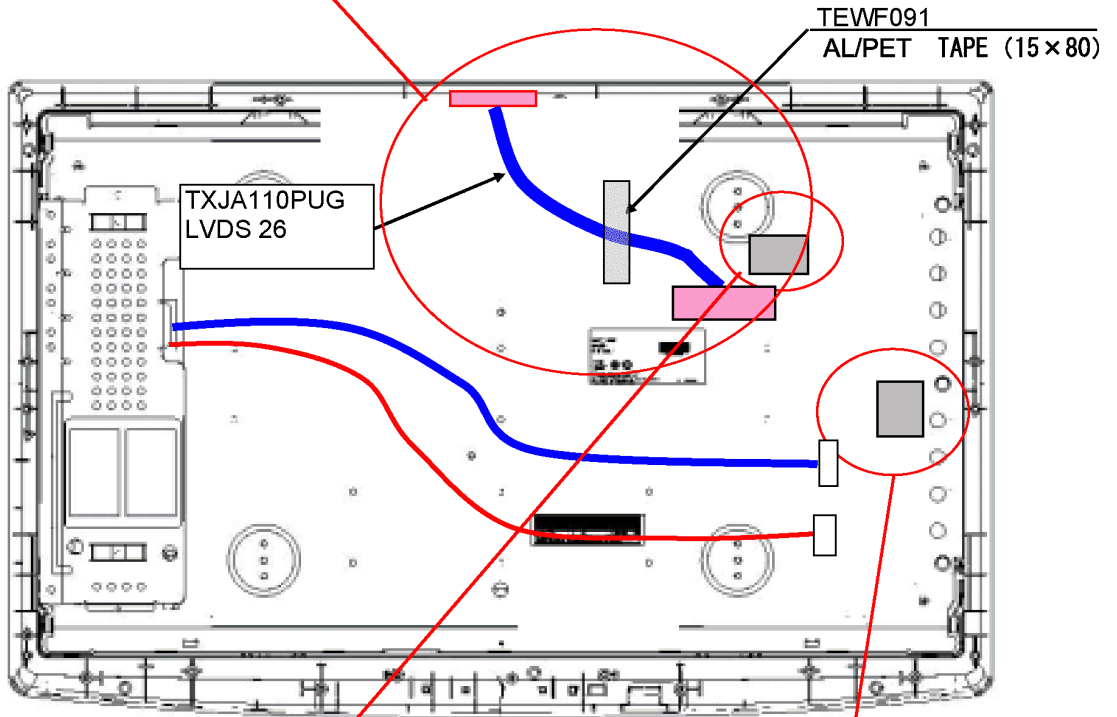
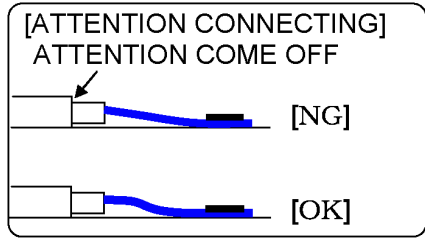
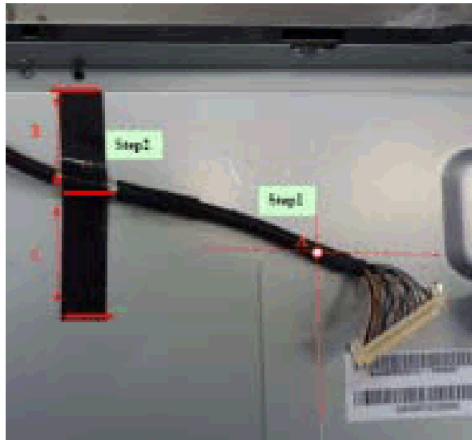

TEW2AG020(2)  
GASKET(18×18×25)

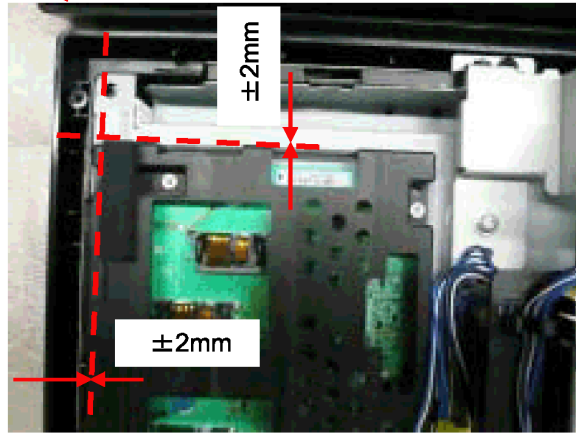
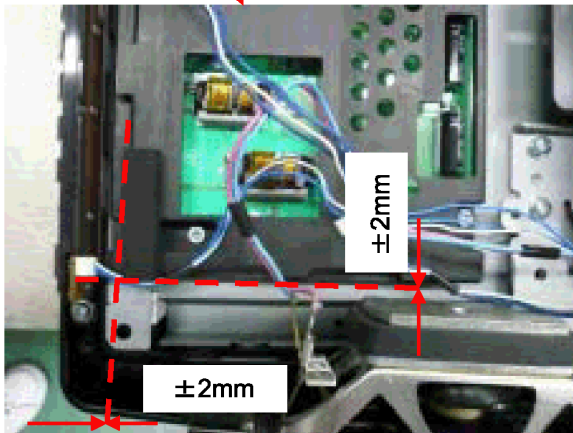
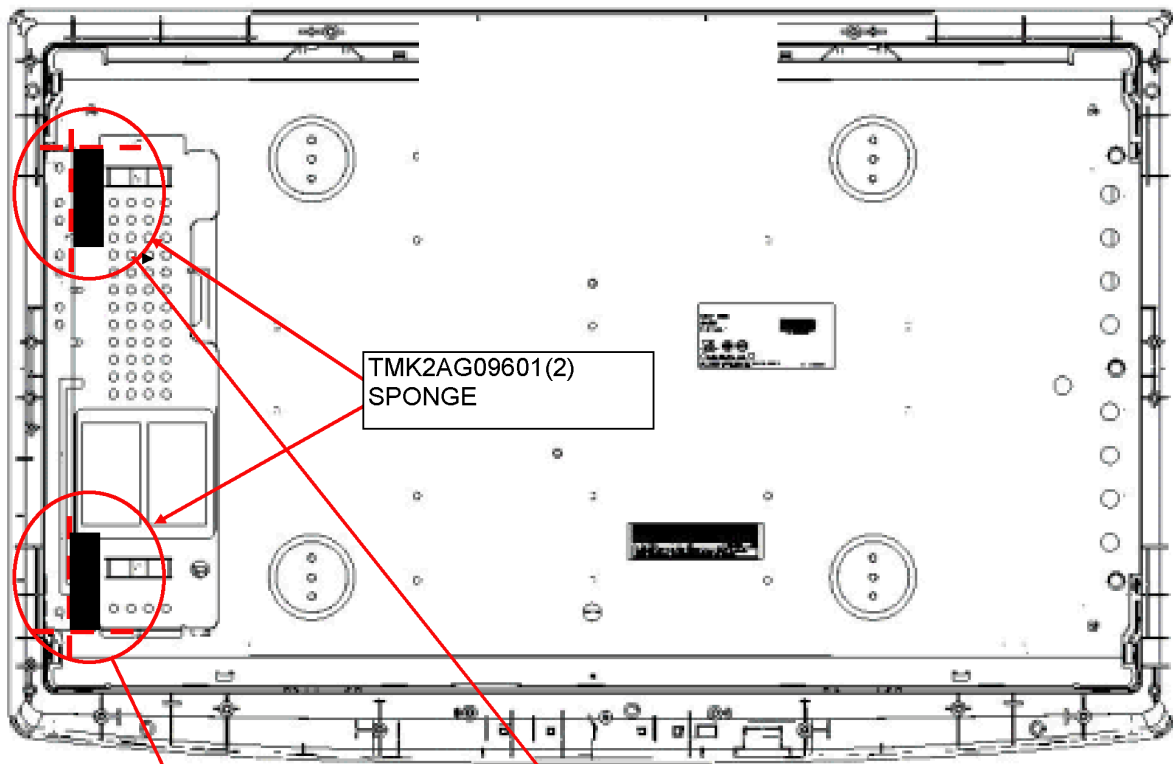

# 8 Measurements and Adjustments

## 8.1. Voltage chart of A-board

VOLTAGE	TEST POINT	SPECIFICATION (Reception state)
STB3.3V	TP2843	3.3 ± 0.16 V
STB1.8V	TP7006	1.84 ± 0.09 V
SUB1.2V	TP5602	1.26 ± 0.06 V
SUB1.8V	TP5601	1.84 ± 0.09 V
SUB3.3V	TP5600	3.3 ± 0.16 V
SUB5V	TP5405	5 ± 0.25 V
SUB9V	TP5481	9 ± 0.45 V
BT30V	TP8300	30 ± 1.5 V
SOUND17V	TP5431	17 ± 0.85 V
DTV12V	TP5432	12 ± 0.6 V
PANEL12V	TP5413	12 ± 0.6 V
5VS	TP5433	5.7 ± 0.28 V
TUNER6V	TP5439	5.7 ± 0.28 V

## 8.2. Picture level adjustment (RF)

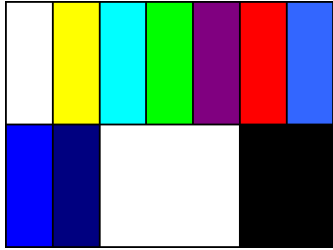
Instrument Name	Remarks
1. REMOTE TRANSMITTER 2. Ex. Signal (Sprit color bar)	
Adjustment or Inspection Procedure	Remarks
<p><b>&lt;procedure&gt;</b></p> <p>1. Receive the Sprit color bar. (Screen mode: ZOOM or FULL Picture mode: DYNAMIC AI: OFF AI Picture: OFF) *BACK LIGHT +30</p> <p><b>&lt;Inspection&gt;</b></p> <p>1. Enter Service mode, and select MAIN_ADJ PICTURE. Volume UP/DOWN key makes GAIN displayed under PICTURE to set. Pushing the remote controller [OK] key for about 3 seconds, GAIN is suited to the adjustment value automatically.</p> <div style="text-align: center;">  <p>(The Sprit Color Bar Pattern)</p> </div>	

### 8.3. Picture level adjustment (VIDEO)

Instrument Name	Remarks
1. REMOTE TRANSMITTER 2. Video signal generator (100% Color bar)	
Adjustment or Inspection Procedure	Remarks
<p><b>&lt;procedure&gt;</b></p> 1. Receive 100% Color bar. (ASPECT: ZOOM or FULL, Picture mode: VIVID, AI Picture: OFF) * BACK LIGHT MAX VALUE	
<p><b>&lt;Inspection&gt;</b></p> 1. Enter Service mode, and select ADJUST CONTRAST. Volume UP/DOWN key makes GAIN value displayed on the right of CONTRAST to set. Pushing the remote controller [OK] key for about 3 seconds, GAIN is suited to the adjustment value automatically.	

### 8.4. Picture level adjustment (YUV)

Instrument Name	Remarks
1. REMOTE TRANSMITTER 2. Component Video signal generator (100% Color bar 1080i)	
Adjustment or Inspection Procedure	Remarks
<p><b>&lt;procedure&gt;</b></p> 1. Receive 100% Color bar. (ASPECT: ZOOM or FULL, Picture mode: VIVID, AI Picture: OFF) * BACK LIGHT MAX VALUE	
<p><b>&lt;Inspection&gt;</b></p> 1. Enter Service mode, and select ADJUST CONTRAST. Volume UP/DOWN key makes GAIN value displayed on the right of CONTRAST to set. Pushing the remote controller [OK] key for about 3 seconds, GAIN is suited to the adjustment value automatically.	

# 9 Block Diagram

## 9.1. Main Block Diagram

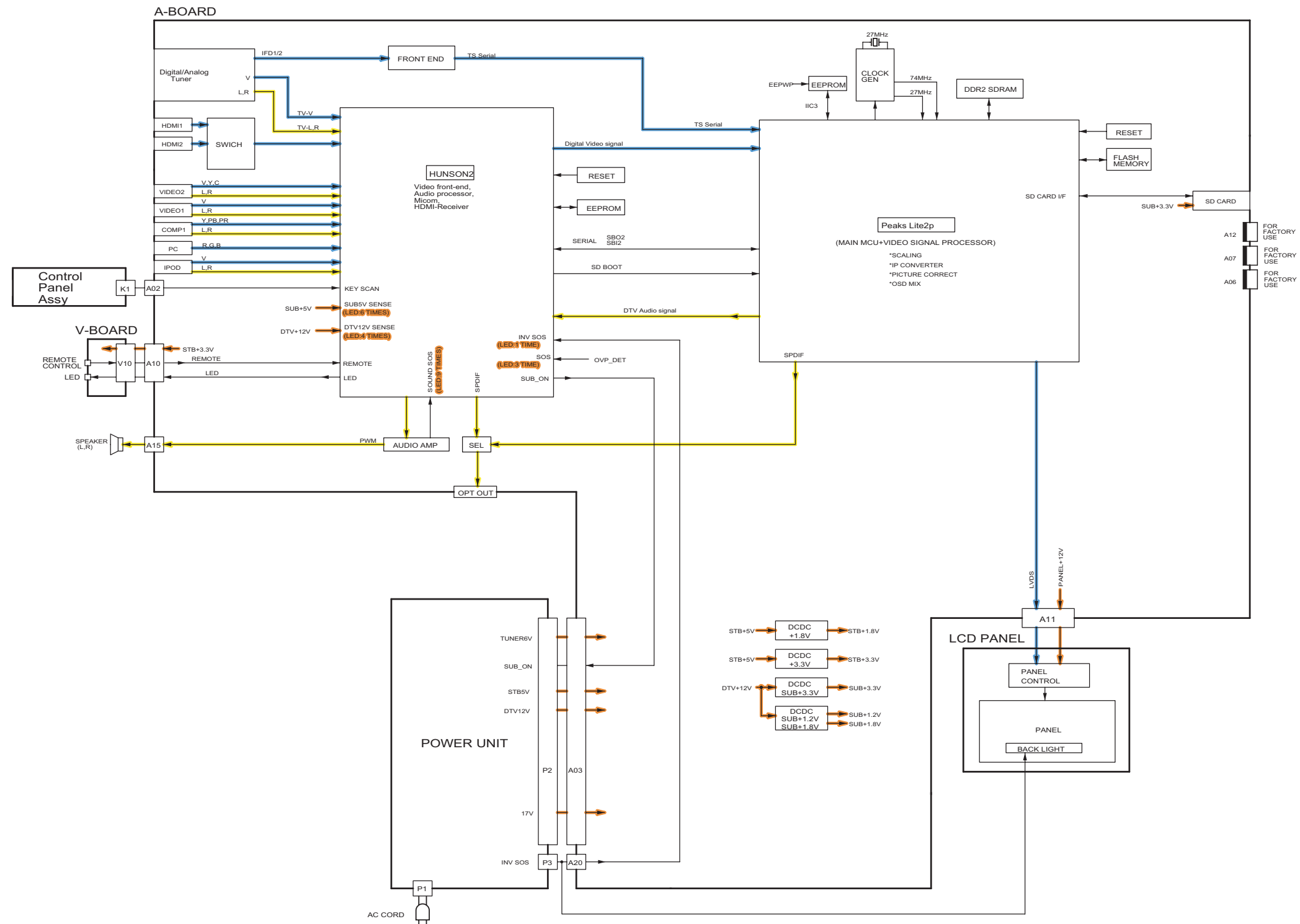

## 9.2. Block (1/2) Diagram

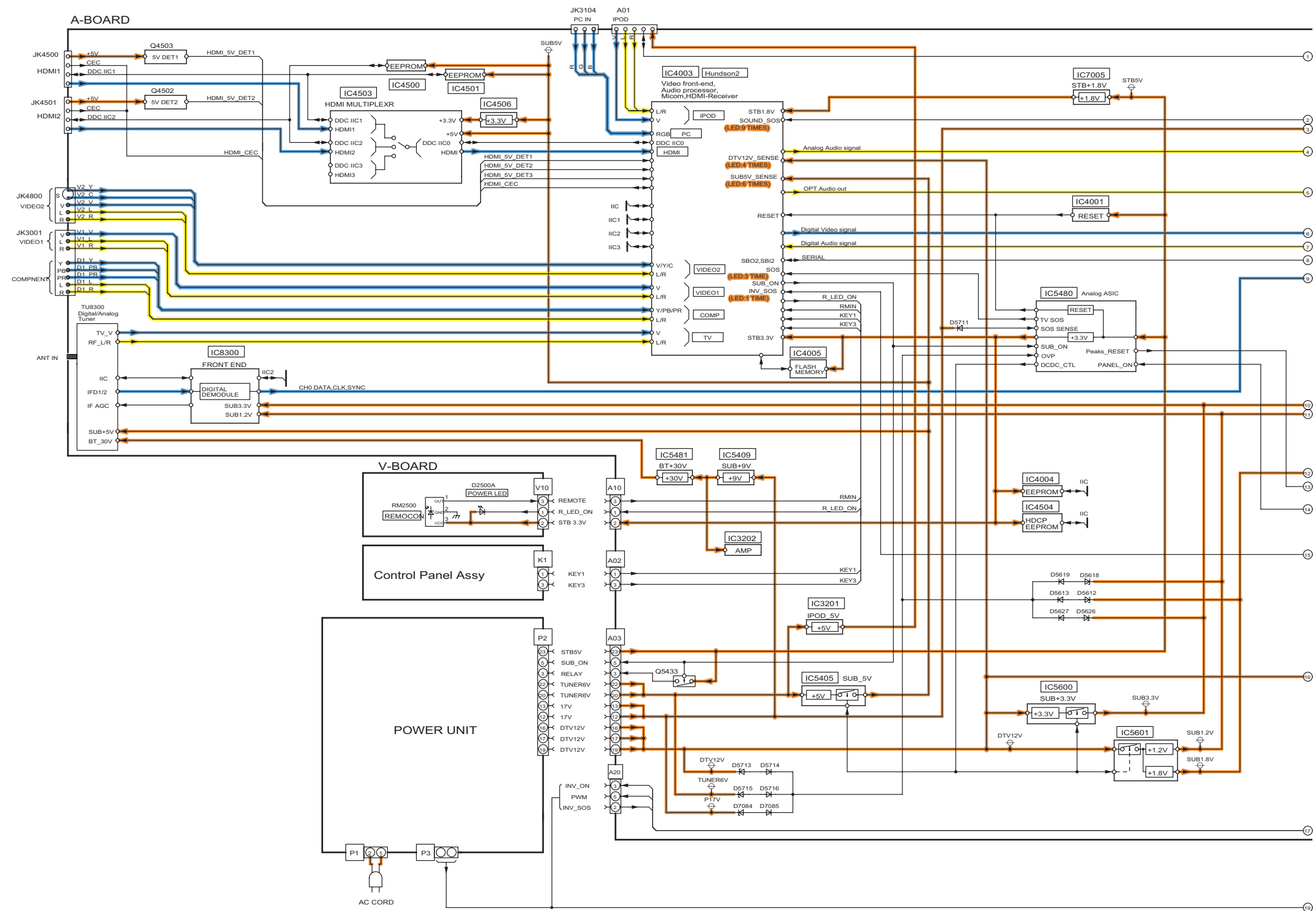

### 9.3. Block (2/2) Diagram

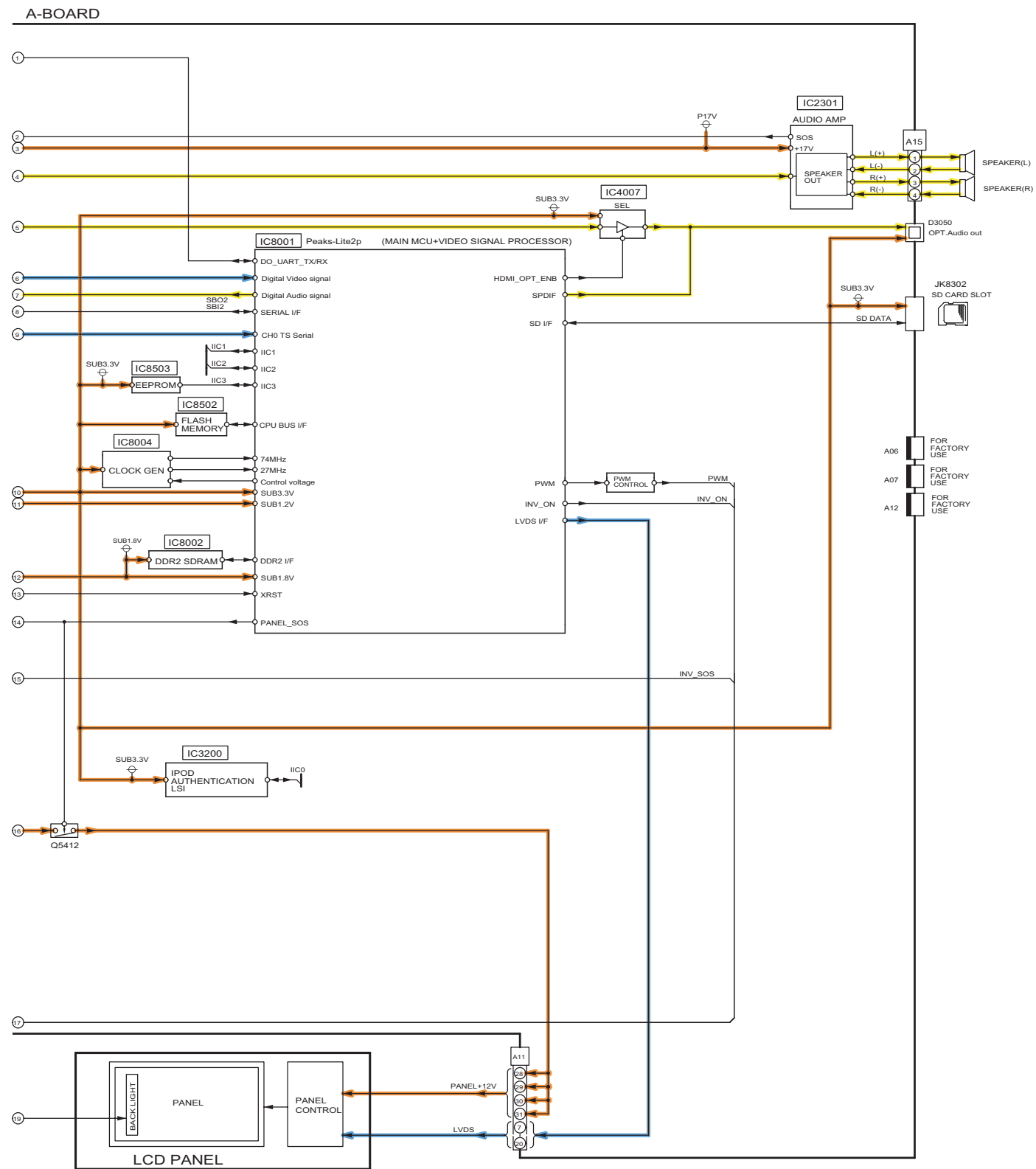



# 10 Wiring Connection Diagram

## 10.1. Caution statement.

**Caution:**

- Please confirm that all flexible cables are assembled correctly.
- Also make sure that they are locked in the connectors.
- Verify by giving the flexible cables a very slight pull.

## 10.2. Wiring

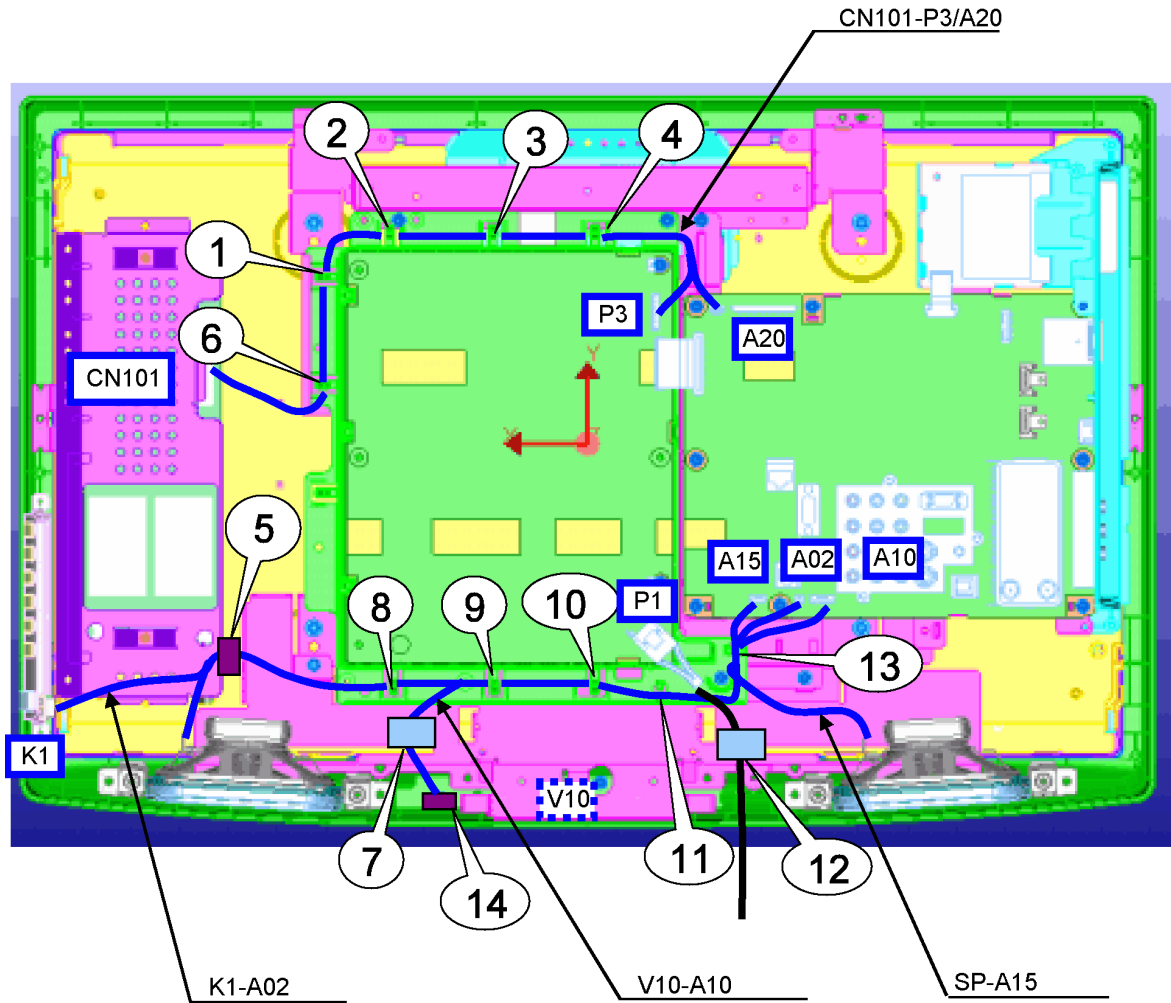

2.PUT CLAMPER TO CHASSIS FRAME

- TMME268.....⑤⑭
- TMME343.....⑫⑦







	①	②	③	④	⑤	⑥	⑦	⑧	⑨	⑩	⑪	⑫	⑬	⑭	⑮
A02-K1					●	●		●	●	●	●		●		
A10-V10							●	●	●	●	●		●	●	
A15-SP					●	●		●	●	●	●		●		
A20 P3-CN101	●	●	●	●											
P1(AC CORD)												●			



# 11 Schematic Diagram

## 11.1. Schematic Diagram Notes

### Notes:

- Resistor**  
Unit of resistance is OHM [ $\Omega$ ] (K=1,000, M=1,000,000).
- Capacitor**  
Unit of capacitance is  $\mu$ F, unless otherwise noted.
- Coil**  
Unit of inductance is H, unless otherwise noted.
- Test Point**  
 : Test Point position
- Earth Symbol**  
 : Chassis Earth (Cold)       : Line Earth (Hot)
- Voltage Measurement**  
Voltage is measured by a DC voltmeter.  
Conditions of the measurement are the following:  
Power Source ..... AC110-127V, 60Hz  
Receiving Signal ..... Colour Bar signal (RF)  
All customer's controls ..... Maximum positions
- When arrow mark () is found, connection is easily found from the direction of arrow.
- Indicates the major signal flow.      : Video       Audio 
- This schematic diagram is the latest at the time of printing and subject to change without notice.

### Remarks:

- The Power Circuit contains a circuit area which uses a separate power supply to isolate the earth connection.  
The circuit is defined by HOT and COLD indications in the schematic diagram. Take the following precautions.  
All circuits, except the Power Circuit, are cold.  
Precautions
  - Do not touch the hot part or the hot and cold parts at the same time or you may be shocked.
  - Do not short- circuit the hot and cold circuits or a fuse may blow and parts may break.
  - Do not connect an instrument, such as an oscilloscope, to the hot and cold circuits simultaneously or a fuse may blow.  
Connect the earth of instruments to the earth connection of the circuit being measured.
  - Make sure to disconnect the power plug before removing the chassis.

# 11.2. A-Board (1/10) Schematic Diagram

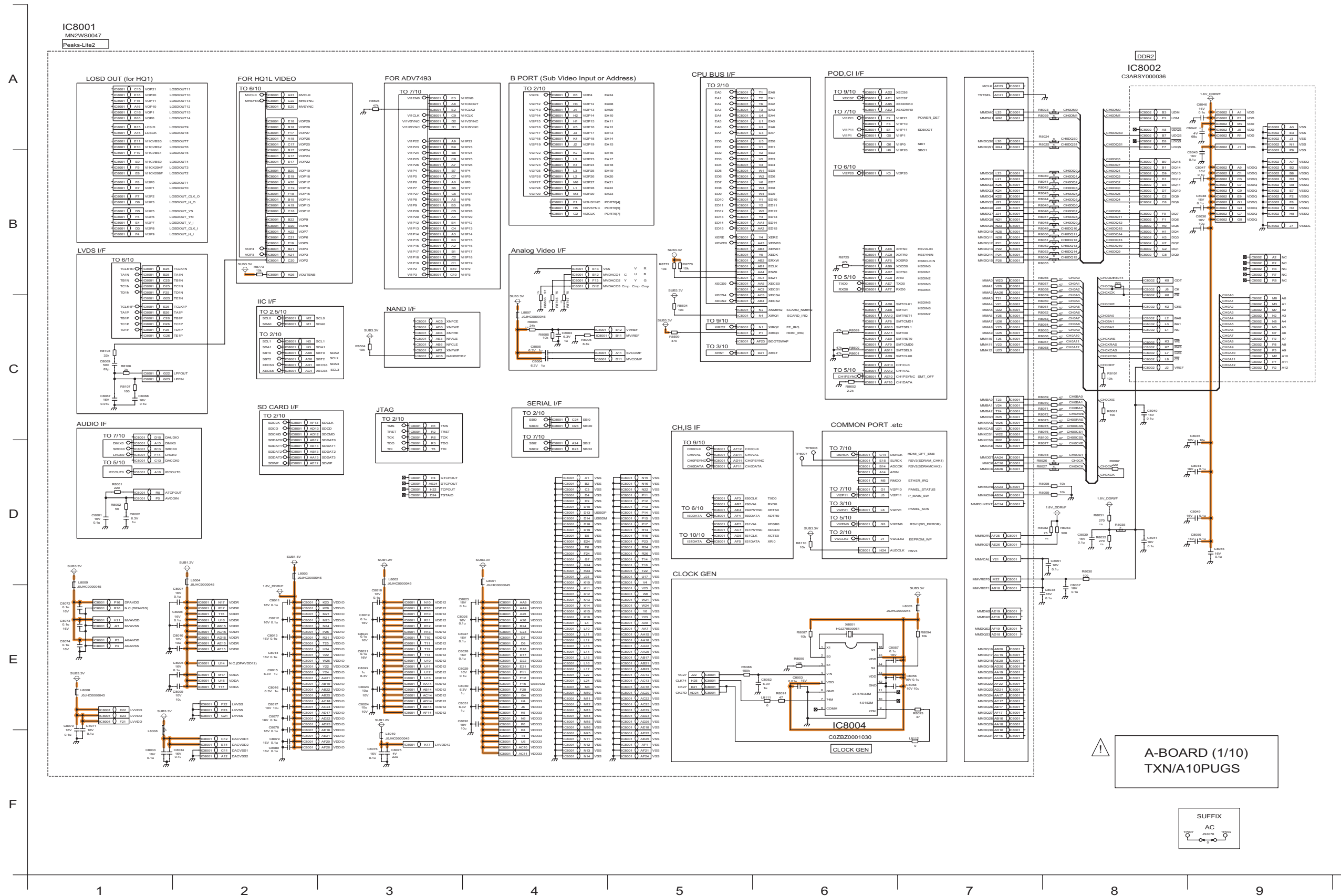

### 11.3. A-Board (2/10) Schematic Diagram

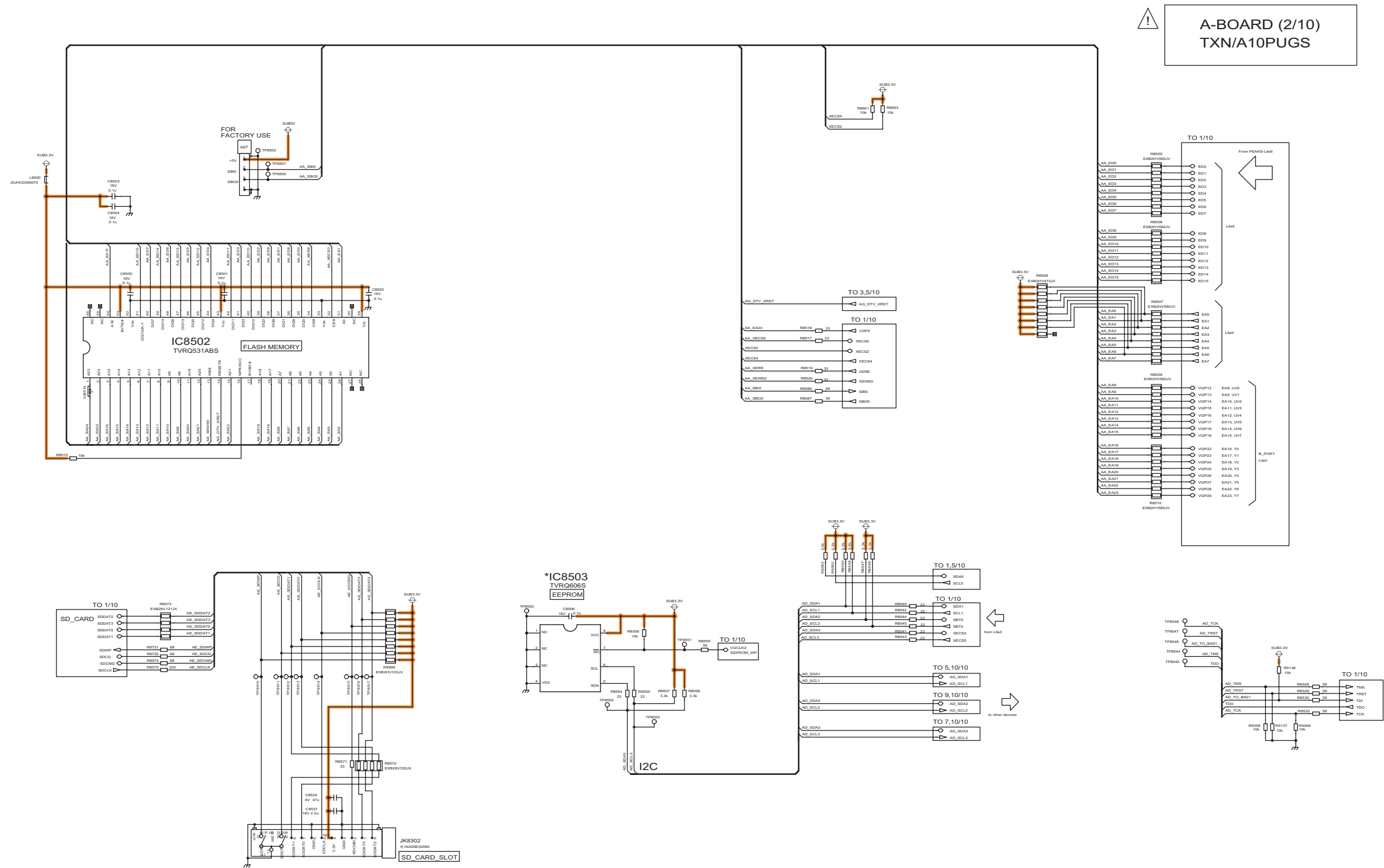

10 11 12 13 14 15 16 17 18

# 11.4. A-Board (3/10) Schematic Diagram

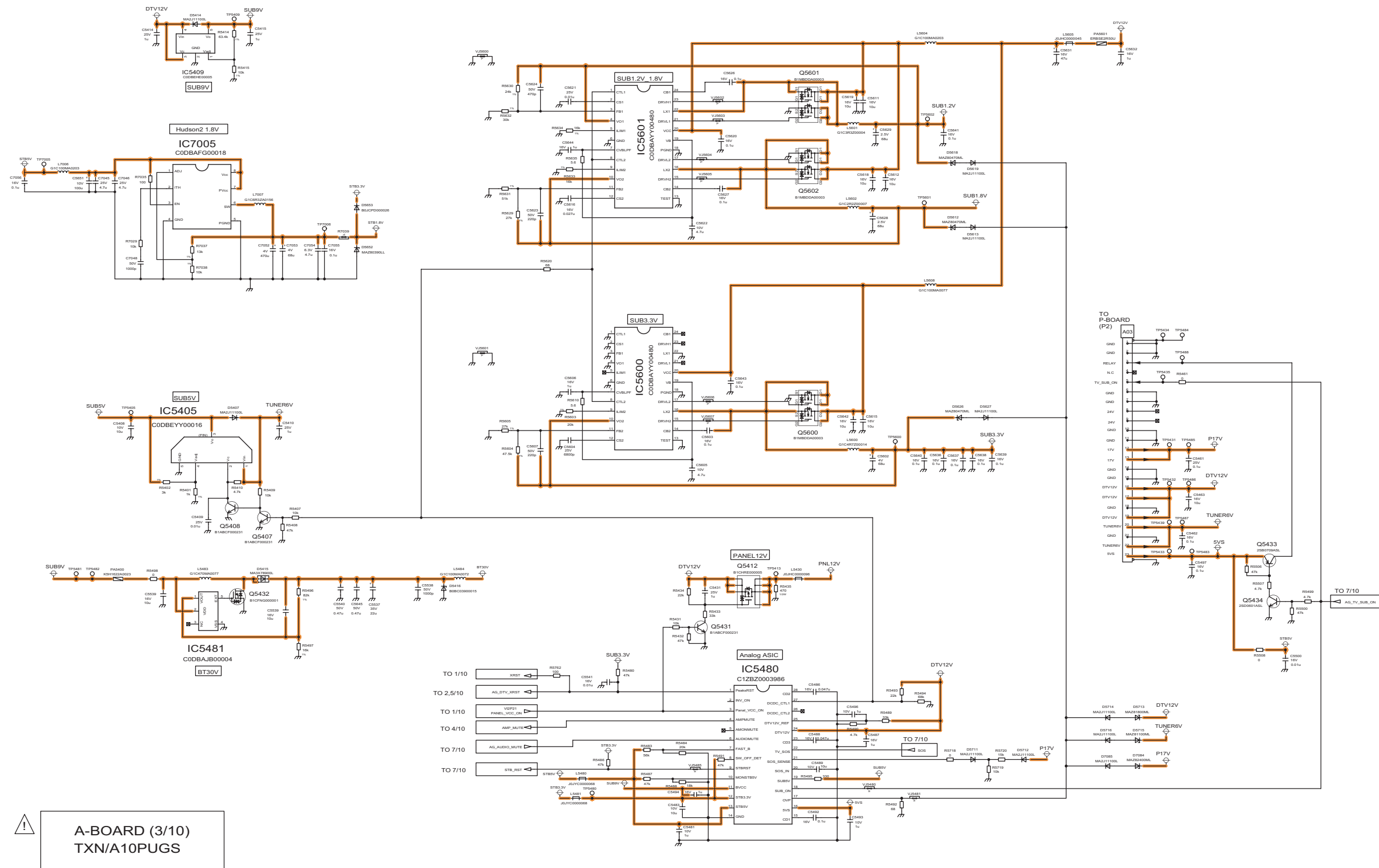

⚠ A-BOARD (3/10)  
TXN/A10PUGS

19 20 21 22 23 24 25 26 27

# 11.5. A-Board (4/10) Schematic Diagram

⚠ A-BOARD (4/10)  
TXN/A10PUGS

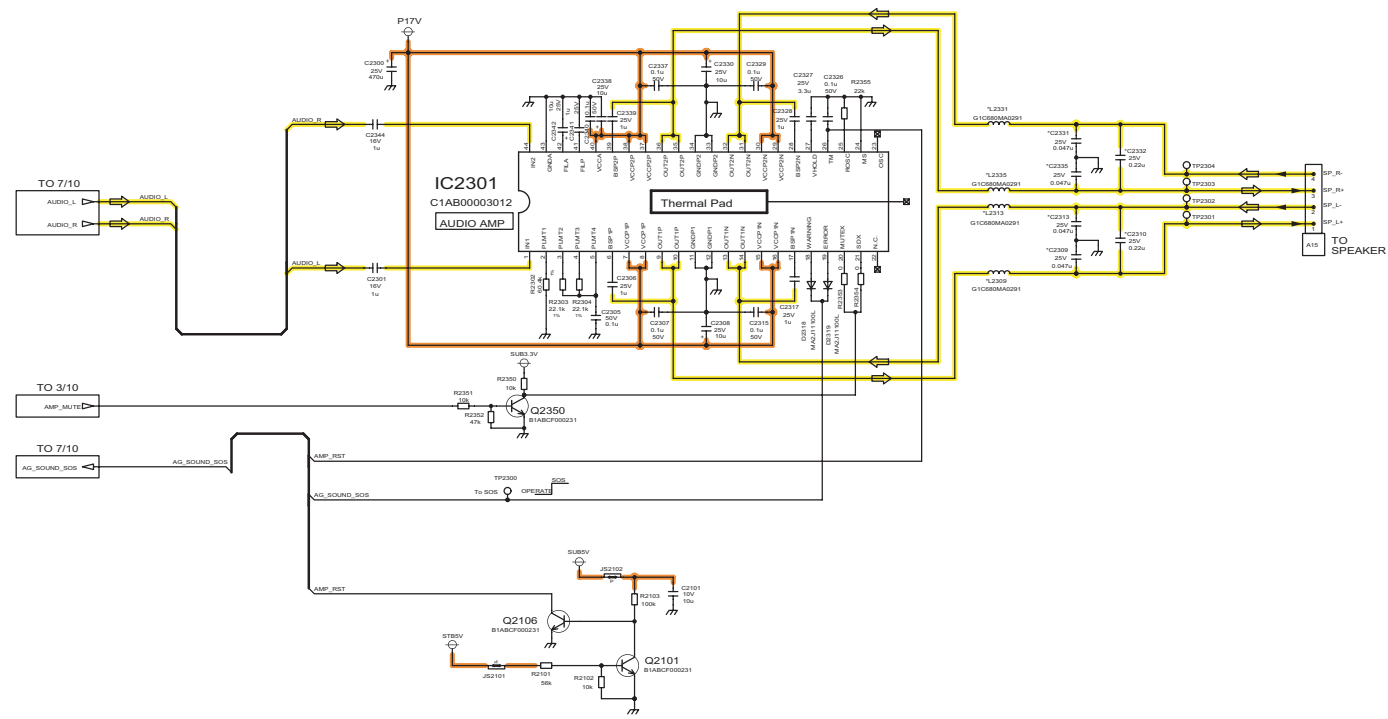

# 11.6. A-Board (5/10) Schematic Diagram

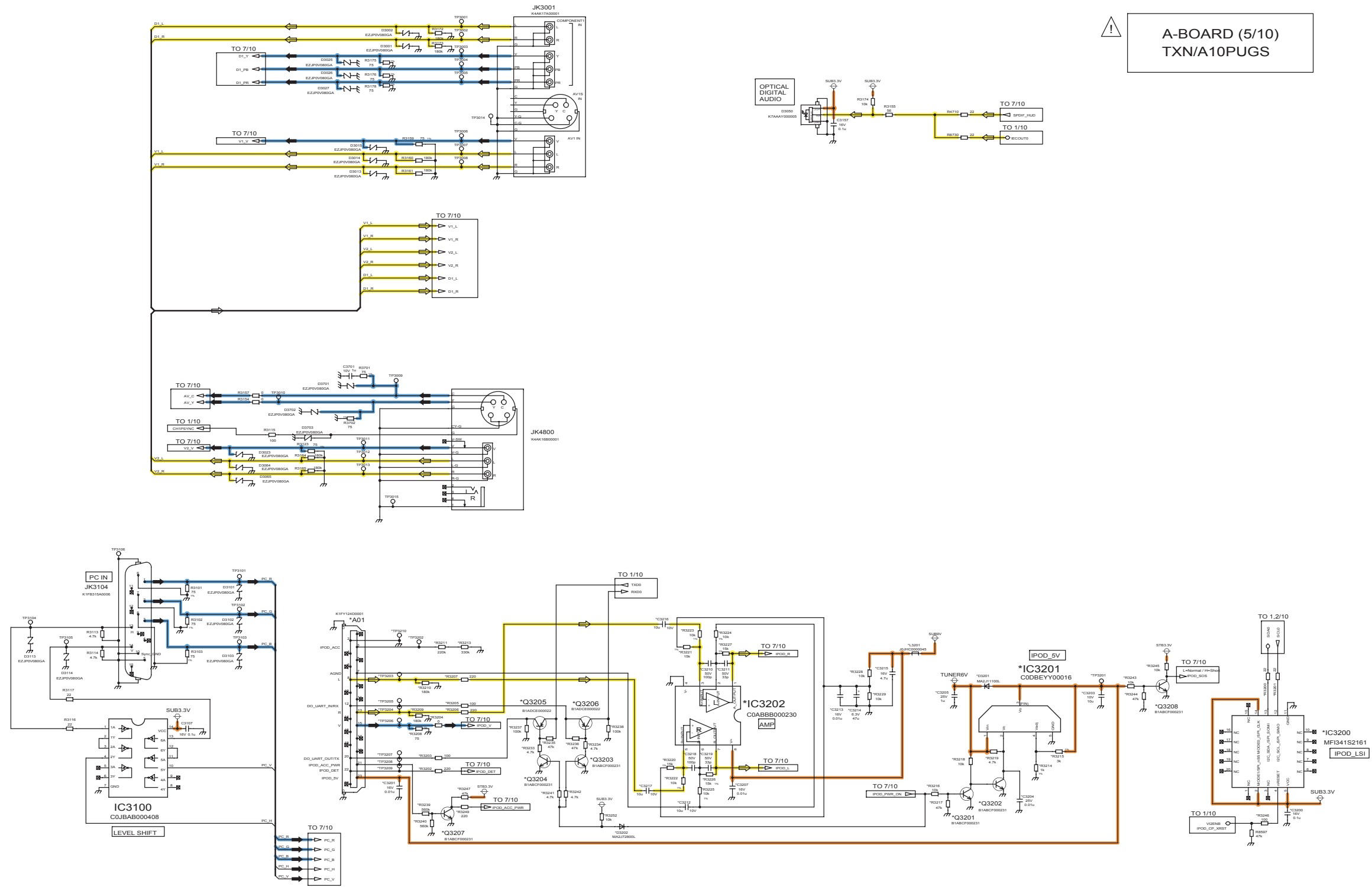

⚠ A-BOARD (5/10)  
TXN/A10PUGS

37

38

39

40

41

42

43

44

45

# 11.7. A-Board (6/10) Schematic Diagram

**A-BOARD (6/10)  
TXN/A10PUGS**

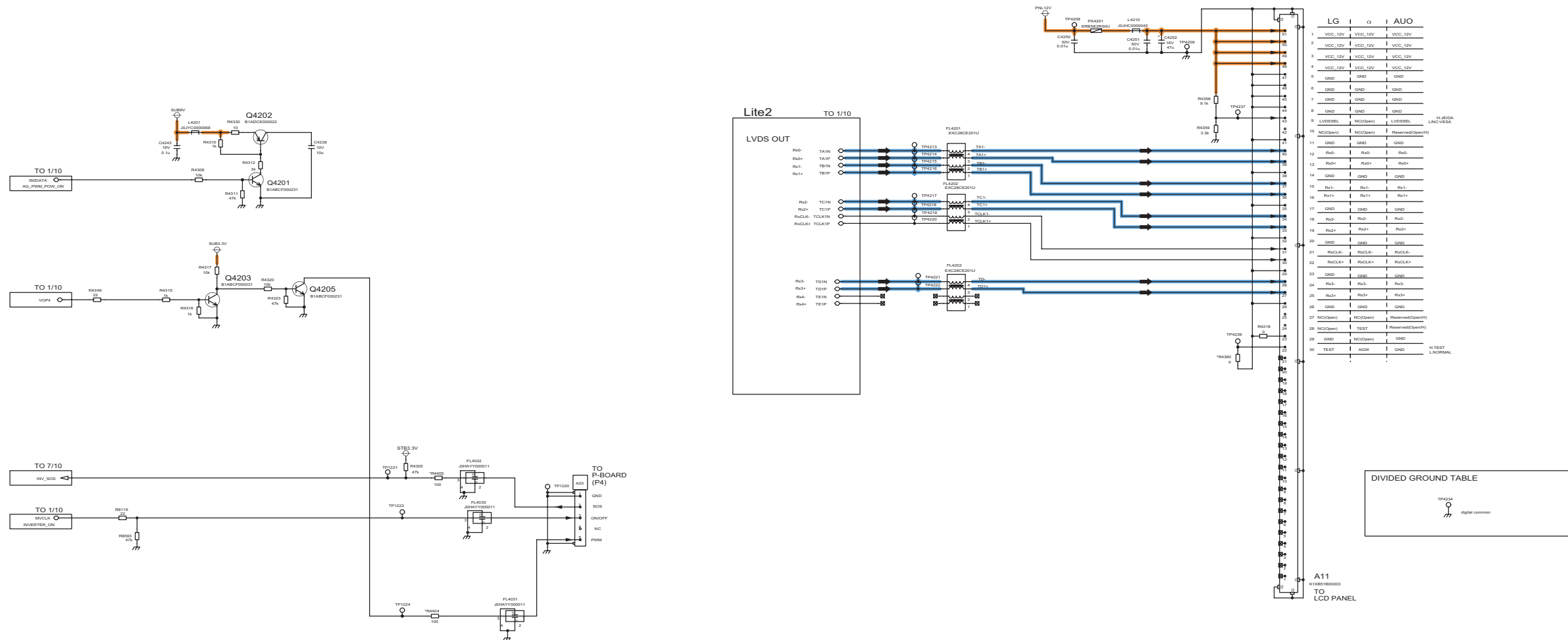

46

47

48

49

50

51

52

53

54



# 11.9. A-Board (8/10) Schematic Diagram

! A-BOARD (8/10)  
TXN/A10PUGS

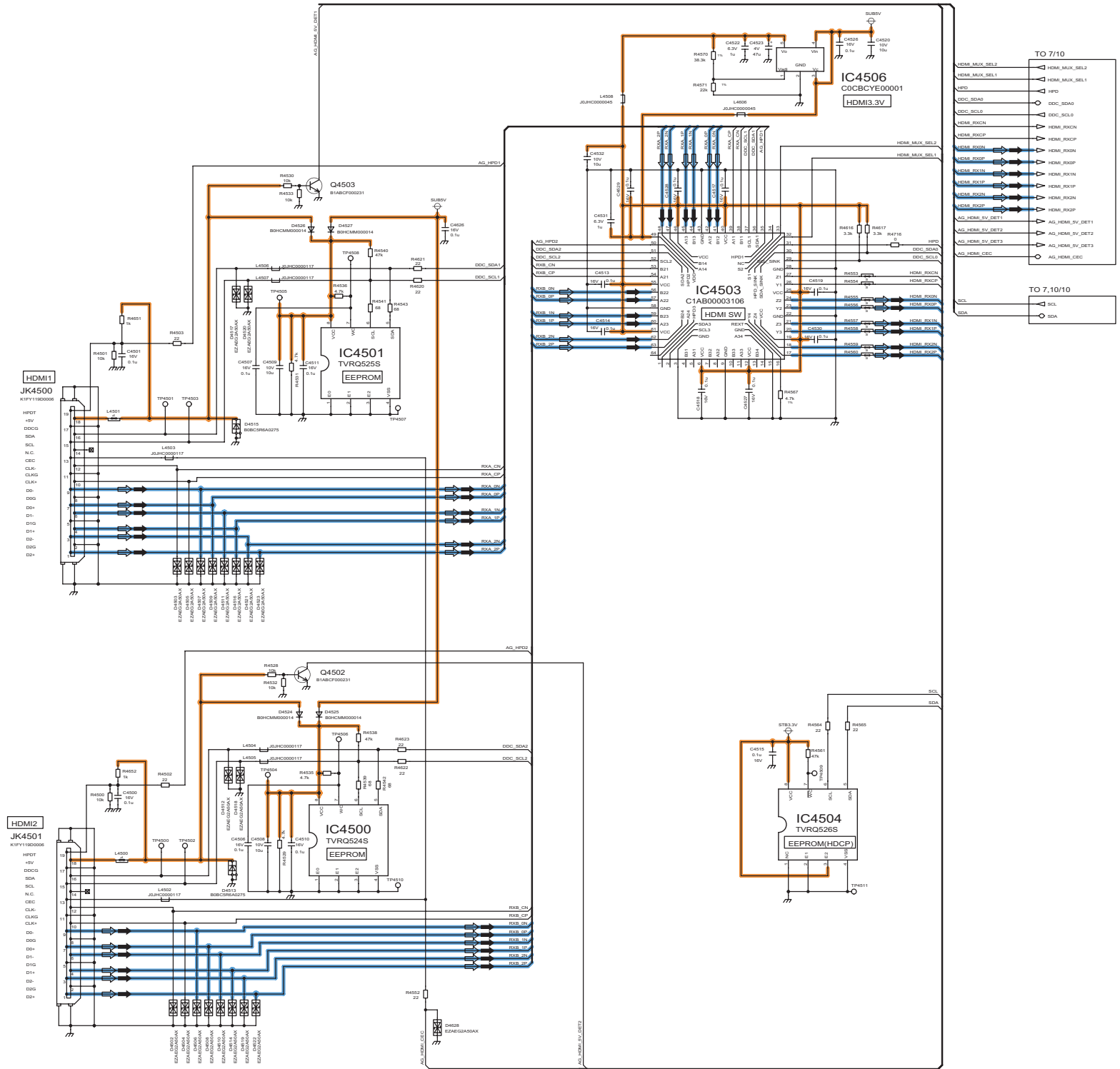

64

65

66

67

68

69

70

71

72

# 11.10. A-Board (9/10) Schematic Diagram

⚠ A-BOARD (9/10)  
TXN/A10PUGS

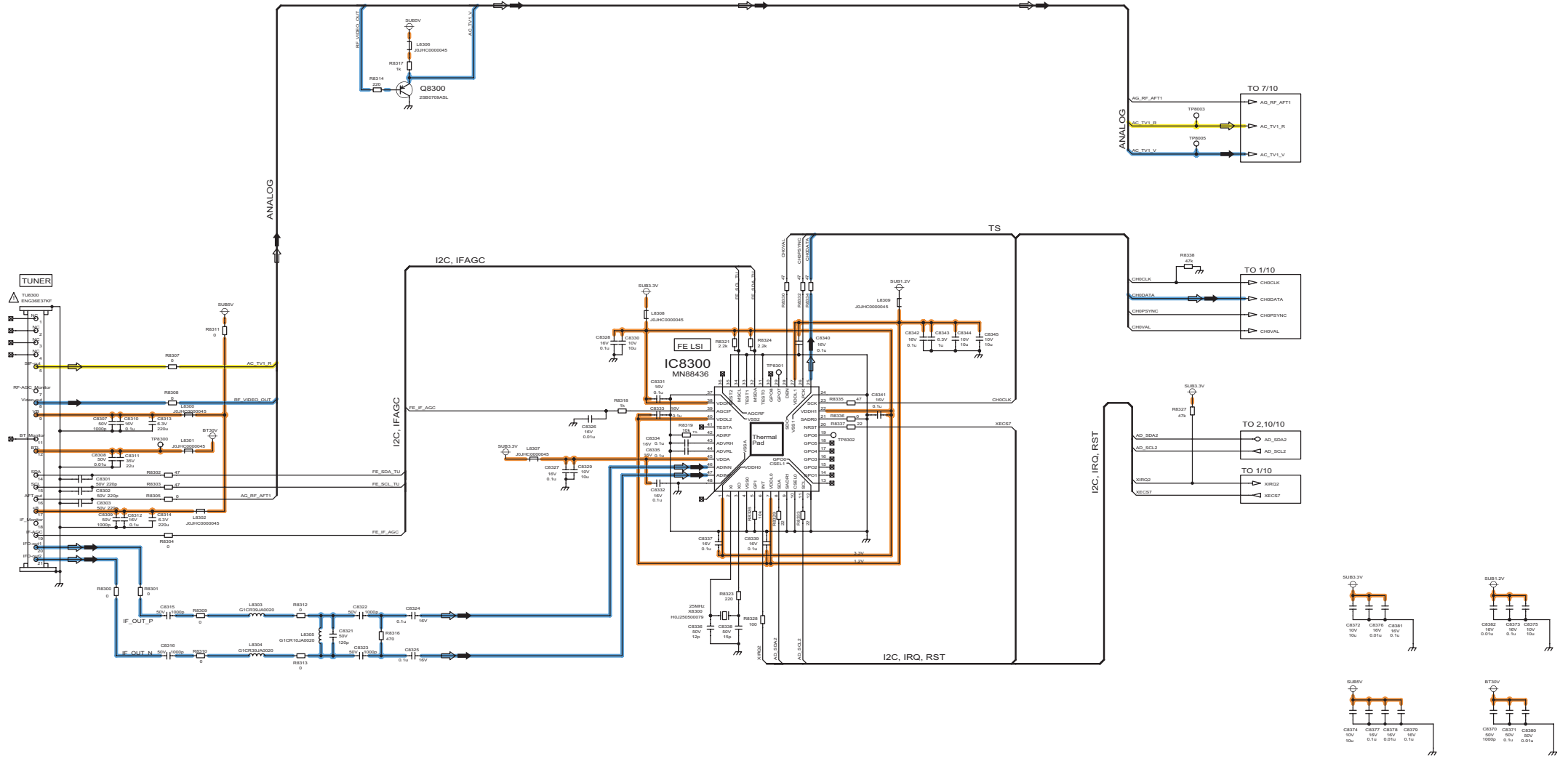

73 74 75 76 77 78 79 80 81

# 11.11. A-Board (10/10) Schematic Diagram

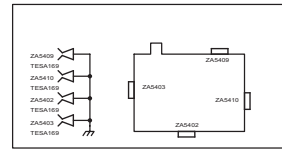
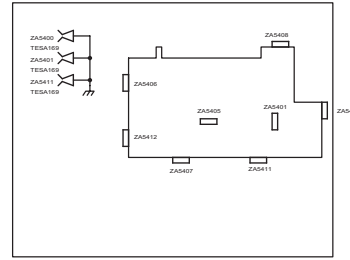

**A-BOARD (10/10)  
TXN/A10PUGS**

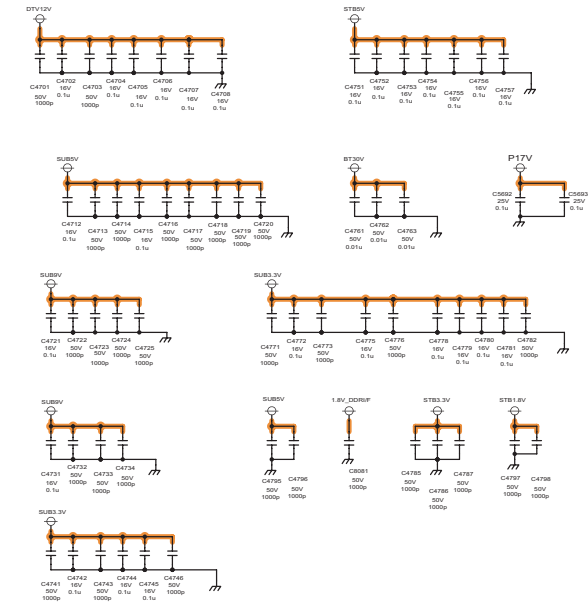
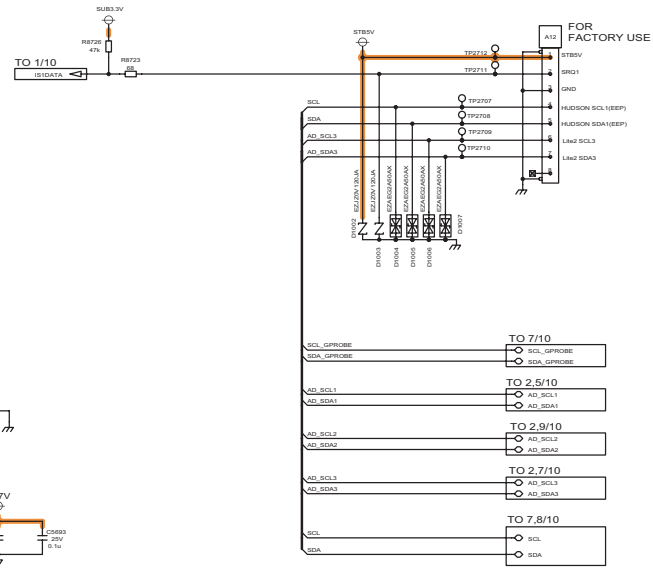

# 11.12. V-Board Schematic Diagram

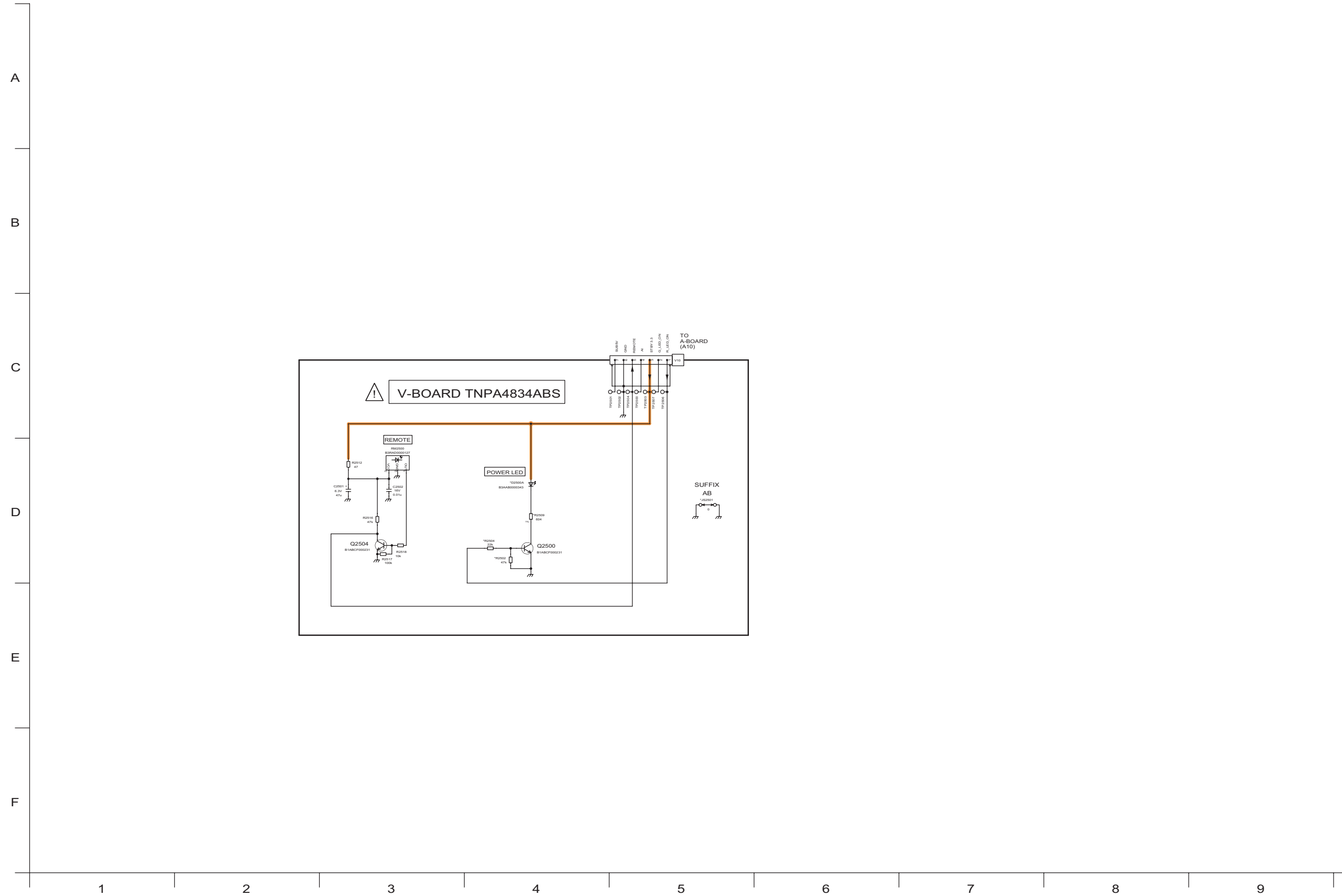

# 12 Printed Circuit Board

## 12.1. A-Board

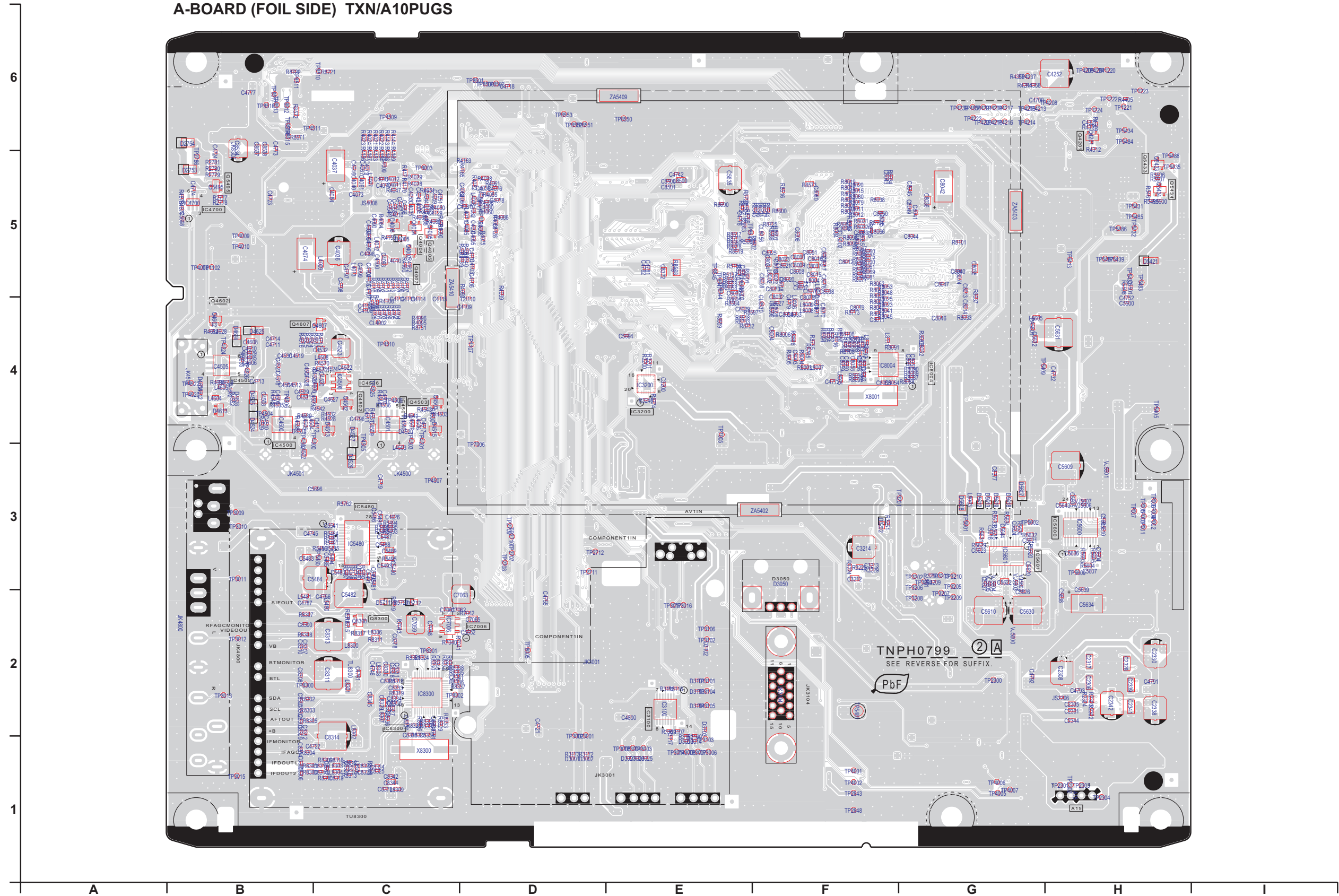

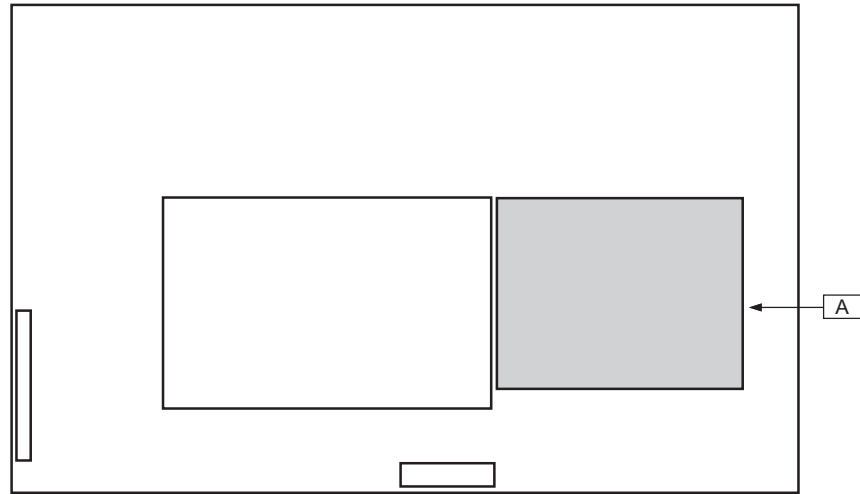

**Parts Location**

A-BOARD (FOIL SIDE)			
IC	TRANSISTOR		
IC3100	E-2	Q4004	C-5
IC3200	E-4	Q4005	C-5
IC4500	B-4	Q4007	C-5
IC4501	C-4	Q4201	H-6
IC4505	B-4	Q4502	C-4
IC4506	C-4	Q4503	C-4
IC4700	C-5	Q4602	B-4
IC5480	C-3	Q4607	B-4
IC5600	H-3	Q5433	H-5
IC5601	G-3	Q5434	H-5
IC8004	G-4	Q5495	B-5
IC8300	C-2	Q8300	C-2

**Parts Location**

A-BOARD (COMPONENT SIDE)			
IC	TRANSISTOR		
IC2301	B-2	Q2033	C-2
IC3201	C-3	Q2035	C-2
IC3202	D-3	Q2036	C-1
IC4001	C-1	Q2040	C-2
IC4003	G-5	Q2101	B-2
IC4004	H-5	Q2106	B-2
IC4005	G-4	Q2350	B-2
IC4007	D-4	Q3201	C-3
IC4008	D-4	Q3202	C-3
IC4503	H-4	Q3203	D-3
IC4504	G-6	Q3204	D-3
IC5405	B-4	Q3205	C-3
IC5409	B-4	Q3206	C-3
IC5481	D-1	Q3207	D-2
IC7005	F-4	Q3208	D-3
IC8001	D-5	Q4000	C-1
IC8002	C-5	Q4202	B-5
IC8003	C-5	Q4203	B-6
IC8502	F-5	Q4204	B-5
IC8503	F-6	Q4205	B-5
		Q4206	B-6
		Q4606	H-4
		Q4616	G-4
		Q4617	G-4
		Q4800	C-6
		Q4807	C-6
		Q5407	B-4
		Q5408	B-4
		Q5412	B-5
		Q5431	B-4
		Q5432	D-2
		Q5600	B-3
		Q5601	B-2
		Q5602	C-3

**A-BOARD (COMPONENT SIDE) TXN/A10PUGS**

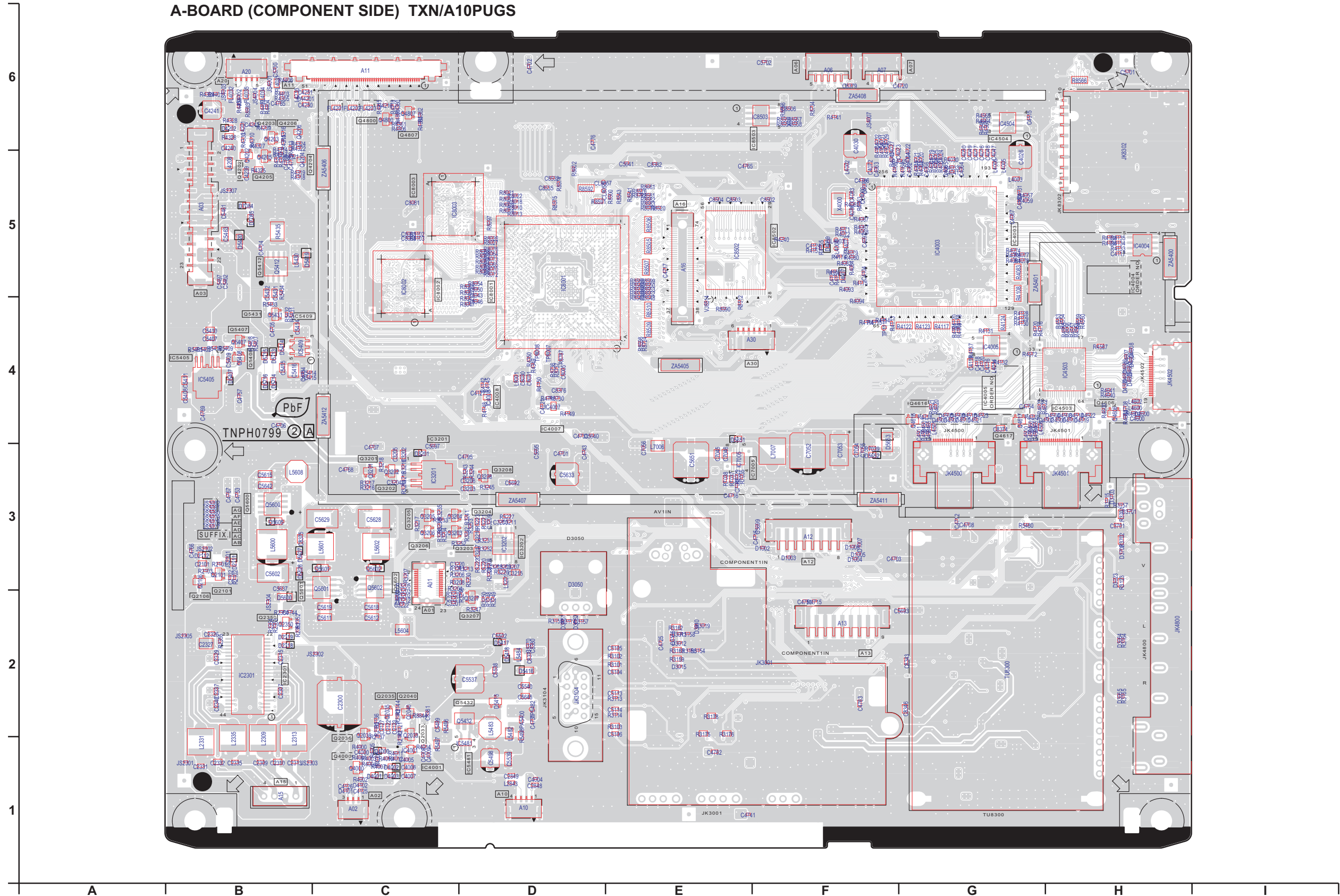

## 12.2. V-Board

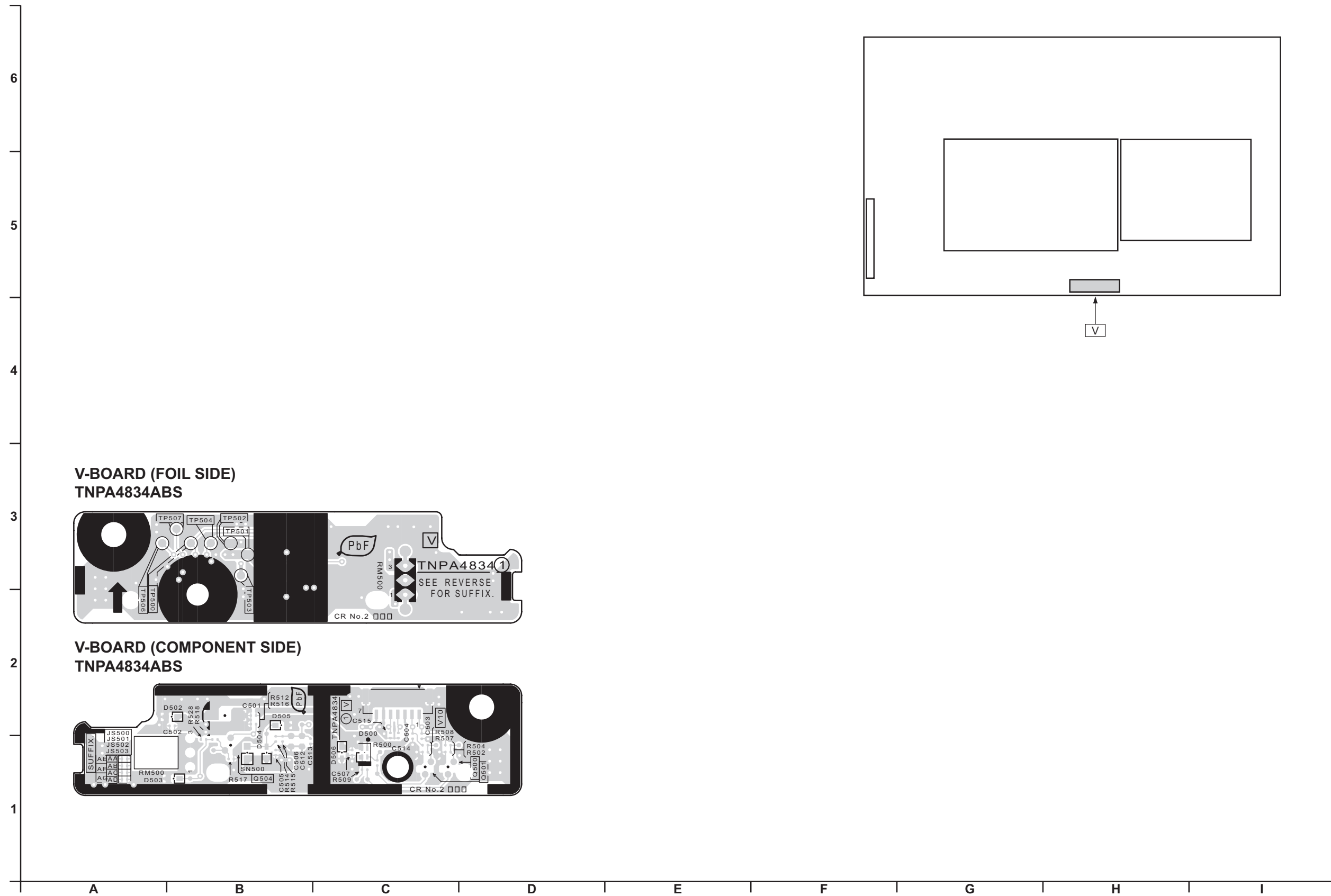

# 13 Exploded View and Replacement Parts List

## 13.1. Exploded View and Mechanical Replacement Parts List

### 13.1.1. Exploded View

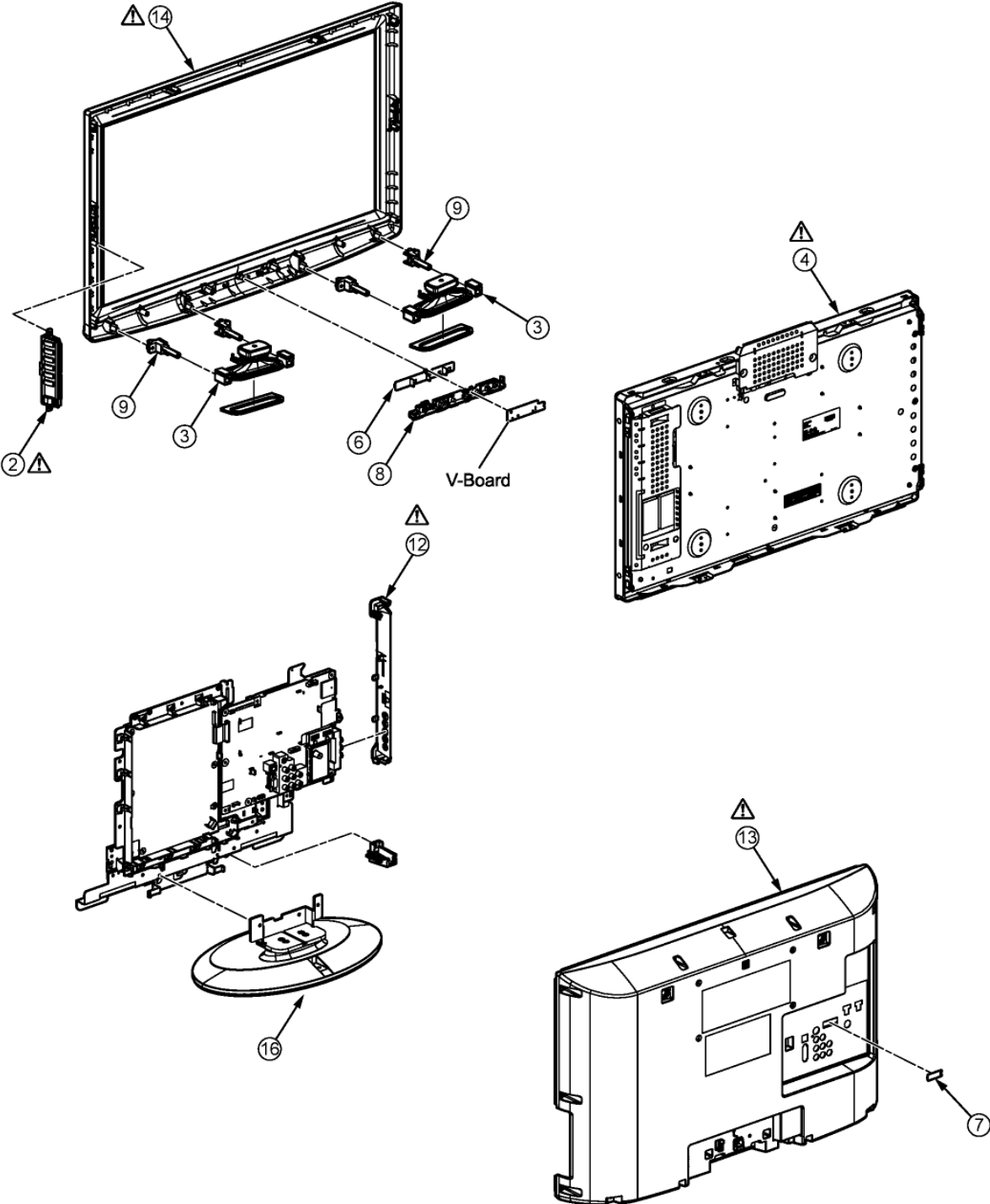



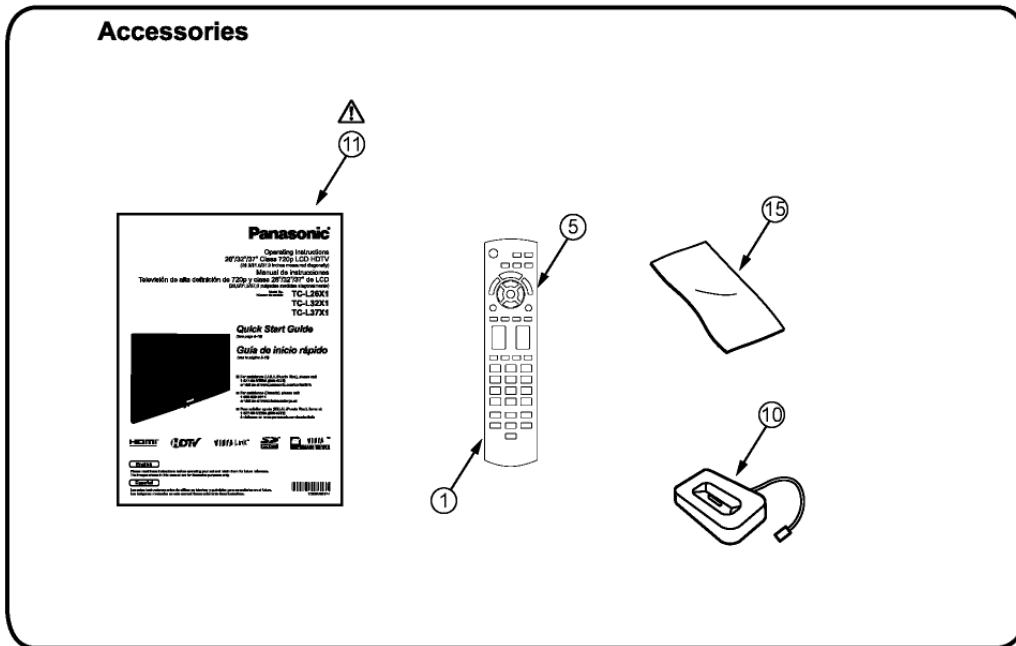



### 13.1.2. Accessory



### 13.1.3. Mechanical Replacement Parts List

**Note:** All parts except parts mentioned [PAVCA] in the Remarks column are supplied by AVC-CSPC.  
Parts mentioned [PAVCA] are supplied by PAVCA.

Safety	Ref. No.	Part No.	Part Name & Description	Q'ty	Remarks
	1	10030-0047500	BATTERY COVER	1	PAVCA
		J0KG00000100	FILTER	1	
	2	K0RB00700013	CONTROLE PANEL ASSY	1	CIRCUIT BOARD&PANERL PAVCA
		K2CB2YY00009	AC CORD	1	PAVCA
	3	L0AA12Z00007	SP UNIT	2	PAVCA
	4	L5EDD6Q00029	LCD PANEL	1	PAVCA
	5	N2QAYB000321	REMOTE CONTROLLER	1	PAVCA
		TEW2AG020	GASKET(t=18.W=18.L=25)	2	PAVCA
		TEWF091	AL/PET TAPE 15x80	1	
		THEL047J	SCREW(HDMI:2)	2	
		THTD020J	SCREW(A-PRINT:4)	20	
	6	TKK2AA10101	LED-SHADE-RIB	1	PAVCA
	7	TKK2AA7901	COVER (ADJ. WINDOW)	1	PAVCA
	8	TKK2AA9901	LED PANEL	1	PAVCA
		TMK2AG09601	SPONGE	2	PAVCA
		TMME268	CLAMPER	2	
		TMME343	CLAMPER	2	
	9	TMW2AA061-1	SP BRACKET	4	PAVCA
	10	TNM2AX0011	I-POD CRADLE	1	PAVCA
	11	TQB2AA0817	INSTRUCTION BOOK	1	PAVCA
	12	TXFKP07WSER	SIDE AV BRACKET	1	PAVCA
	13	TXFKU07WSER	REAR COVER	1	PAVCA
	14	TXFKY010PUG	CABINET ASSY	1	PAVCA
	15	TXFPE01RLTU	CLEANING CLOTH ASSY	1	
		TXJA110PUG	LVDS LEAD	1	PAVCA
		TXJA150PUG	SPEAKER LEAD (A15-SP)	1	PAVCA
		XTB4+12JFJ	SCREW	2	
		XTB4+15JFJ	SCREW	13	
		XTB4+18JFJK	SCREW (BCX11)	15	
		XTV3+10GFJK	SCREW(REAR BRKT2)	2	
		XTW3+12TFJ	SCREW	4	
		XYM4+C10FJK	SCREW(PEDE4)	4	
		XYM4+C10FJK	SCREW	4	
		XYN4+F6FJ	SCREW (LCD BTM MTG)	6	
	16	TBL2AX261SER	PEDESTAL ASSY	1	PAVCA
		TKX2AA0351	PEDESTAL COVER	1	PAVCA

## 13.2. Electrical Replacement Parts List

### 13.2.1. Replacement Parts List Notes

#### RTL (Retention Time Limited)

**Note:** The marking (RTL) indicates that the Retention Time is Limited for this item.

After the discontinuation of this assembly in production, the item will continue to be available for a specific period of time. The retention period of availability is dependant on the type of assembly, and in accordance with the laws governing part and product retention. After the end of this period, the assembly will no longer be available.

Abbreviation of part name and description

#### 1. Resistor

Example:

ERD25TJ104    C 100KOHM, J, 1/4W  
                   Type            Allowance

#### 2. Capacitor

Example:

ECKF1H103ZF    C 0.01UF, Z, 50V  
                   Type            Allowance

Type	Allowance
C : Carbon	F : ±1%
F : Fuse	G : ±2%
M : Metal Oxide Metal Film	J : ±5%
S : Solid	K : ±10%
W : Wire Wound	M : ±20%

Type	Allowance
C : Ceramic	C : ±0.25pF
E : Electrolytic	D : ±0.5pF
P : Polyester	F : ±1pF
Polyprop lene	G : ±3pF
T : Tantalum	J : ±5pF
	K : ±10pF
	L : ±15pF
	M : ±20pF
	P : +100%, -0%
	Z : +80%, -20%

### 13.2.2. Electrical Replacement Parts List

**Note:** All parts except parts mentioned [PAVCA] in the Remarks column are supplied by AVC-CSPC. Parts mentioned [PAVCA] are supplied by PAVCA.

Safety	Ref. No.	Part No.	Part Name & Description	Pcs	Remarks
	A01	K1FY124D0001	12P CONNECTOR	1	PAVCA
	A02	K1KA03A00632	3P CONNECTOR	1	
	A03	K1KY23AA0607	23P CONNECTOR	1	
	A06	K1KA05BA0047	5P CONNECTOR	1	
	A07	K1KA04BA0047	4P CONNECTOR	1	
	A10	K1KA04A00667	4P CONNECTOR	1	
	A11	K1KB51B00003	51P CONNECTOR	1	
	A12	K1KA08AA0728	8P CONNECTOR	1	
	A15	K1KA04AA0190	4P CONNECTOR	1	
	A20	K1KA05A00466	5P CONNECTOR	1	
	C2101	F1J1A106A043	C 0.010UF, K, 10V	1	
	C2300	EEFEG1E471P	E 470UF, 25V	1	
	C2301	F1H1C105A145	C 0.01UF, K, 16V	1	
	C2305	F1H1H104A970	C 0.1UF, K, 50V	1	
	C2306	F1K1E105A029	C 1UF, Z, 25V	1	
	C2307	F1H1H104A970	C 0.1UF, K, 50V	1	
	C2308	F2G1E100A021	E 10UF, 25V	1	PAVCA
	C2309	F1H1E104A129	C 0.1UF, 25V	1	
	C2310	F1J1H474A757	C 0.47UF, 50V	1	
	C2313	F1H1E104A129	C 0.1UF, 25V	1	
	C2315	F1H1H104A970	C 0.1UF, K, 50V	1	
	C2317	F1K1E105A029	C 1UF, Z, 25V	1	
	C2326	F1H1H104A970	C 0.1UF, K, 50V	1	
	C2327	ECJ4YB1E335K	C 3.3UF, 25V	1	PAVCA
	C2328	F1K1E105A029	C 1UF, Z, 25V	1	
	C2329	F1H1H104A970	C 0.1UF, K, 50V	1	
	C2330	F2G1E100A021	E 10UF, 25V	1	PAVCA
	C2331	F1H1E104A129	C 0.1UF, 25V	1	
	C2332	F1J1H474A757	C 0.47UF, 50V	1	
	C2335	F1H1E104A129	C 0.1UF, 25V	1	
	C2337	F1H1H104A970	C 0.1UF, K, 50V	1	
	C2338	F2G1E100A021	E 10UF, 25V	1	PAVCA
	C2339	F1K1E105A029	C 1UF, Z, 25V	1	
	C2340	F1H1H104A970	C 0.1UF, K, 50V	1	
	C2341	F1K1E105A029	C 1UF, Z, 25V	1	
	C2342	F2G1E100A021	E 10UF, 25V	1	PAVCA
	C2344	F1H1C105A145	C 0.01UF, K, 16V	1	
	C2501	F2G0J470A019	E 47UF 6.3V	1	
	C2502	F1G1C103A116	C 0.010UF, K, 16V	1	
	C2848	F1H1H102A971	C 1000PF, K, 50V	1	
	C3107	F1G1C104A116	C 0.10UF, K, 16V	1	
	C3157	F1G1C104A116	C 0.10UF, K, 16V	1	
	C3200	F1G1C104A116	C 0.10UF, K, 16V	1	
	C3201	F1G1C1030008	C 0.010UF, K, 16V	1	
	C3203	F1J1A106A043	C 0.010UF, K, 10V	1	
	C3204	F1G1E103A123	C 0.010UF, K, 25V	1	
	C3205	F1J1E105A171	C 1 UF 25V	1	
	C3207	F1G1C1030008	C 0.010UF, K, 16V	1	
	C3210	F1G1H101A731	C 100PF, K, 50V	1	
	C3211	F1G1H330A731	C 33UF, 50V	1	
	C3212	F1J1A106A043	C 0.010UF, K, 10V	1	
	C3213	F1G1C1030008	C 0.010UF, K, 16V	1	
	C3214	F2G0J470A019	E 47UF 6.3V	1	
	C3215	ECJ2FF1C475Z	C 4.7UF, Z, 16V	1	

Safety	Ref. No.	Part No.	Part Name & Description	Pcs	Remarks
	C3216,17	F1J1A106A043	C 0.010UF, K, 10V	2	
	C3218	F1G1H101A731	C 100PF, K, 50V	1	
	C3219	F1G1H330A731	C 33UF, 50V	1	
	C3701	F1H1A1050032	C 10UF, 50V	1	
	C4000	F1H1H102A971	C 1000PF, K, 50V	1	
	C4004	F1G1C104A116	C 0.10UF, K, 16V	1	
	C4006,07	F1J1A106A043	C 0.010UF, K, 10V	2	
	C4008	F1G1H101A731	C 100PF, K, 50V	1	
	C4011,12	F1H1A1050032	C 10UF, 50V	2	
	C4016,17	F1H1A1050032	C 10UF, 50V	2	
	C4019-22	F1G1C104A116	C 0.10UF, K, 16V	4	
	C4023	F1H1H223A970	C 0.22UF, K, 50V	1	
	C4024,25	F1G1C104A116	C 0.10UF, K, 16V	2	
	C4026	F2G0G101A007	E 100UF 6.3V	1	
	C4027	F1H1H223A970	C 0.22UF, K, 50V	1	
	C4029	F1G1C104A116	C 0.10UF, K, 16V	1	
	C4030	F2G0G101A007	E 100UF 6.3V	1	
	C4031,32	F1G1C104A116	C 0.10UF, K, 16V	2	
	C4036	F2G0G101A007	E 100UF 6.3V	1	
	C4039	F1G1C104A116	C 0.10UF, K, 16V	1	
	C4040	F1J1A106A043	C 0.010UF, K, 10V	1	
	C4041	F1G1C104A116	C 0.10UF, K, 16V	1	
	C4044	F1G1C104A116	C 0.10UF, K, 16V	1	
	C4046	F1G1C104A116	C 0.10UF, K, 16V	1	
	C4047-50	F1H1A1050032	C 10UF, 50V	4	
	C4051-60	F1G1C104A116	C 0.10UF, K, 16V	10	
	C4061	F1J0G2260001	C 0.001UF, 6.3V	1	
	C4062-67	F1G1C103A116	C 0.010UF, K, 16V	6	
	C4072	F1J0G2260001	C 0.001UF, 6.3V	1	
	C4073	F1H1A225A051	C 22UF, 50V	1	
	C4075	F1G1C103A116	C 0.010UF, K, 16V	1	
	C4076-78	F1G1C104A116	C 0.10UF, K, 16V	3	
	C4079	F1G1C103A116	C 0.010UF, K, 16V	1	
	C4080-82	F1G1C104A116	C 0.10UF, K, 16V	3	
	C4083	F1H1H100A971	C 10PF, K, 50V	1	
	C4084	F1J0G2260001	C 0.001UF, 6.3V	1	
	C4085	F1H0J1050012	C 1UF, K, 16V	1	
	C4086	F1H1H100A971	C 10PF, K, 50V	1	
	C4087	F1G1C103A116	C 0.010UF, K, 16V	1	
	C4090-92	F1G1C103A116	C 0.010UF, K, 16V	3	
	C4093	F1J0G2260001	C 0.001UF, 6.3V	1	
	C4094-97	F1G1C103A116	C 0.010UF, K, 16V	4	
	C4098	F1G1C104A116	C 0.10UF, K, 16V	1	
	C4099-15	F1G1C103A116	C 0.010UF, K, 16V	17	
	C4116	F1H1A1050032	C 10UF, 50V	1	
	C4117,18	F1G1C104A116	C 0.10UF, K, 16V	2	
	C4119	F1J1A106A043	C 0.010UF, K, 10V	1	
	C4120	F1G1H101A731	C 100PF, K, 50V	1	
	C4121	F1G1C104A116	C 0.10UF, K, 16V	1	
	C4125,26	F1G1C103A116	C 0.010UF, K, 16V	2	
	C4127	F1G1C104A116	C 0.10UF, K, 16V	1	
	C4129	F1G1C104A116	C 0.10UF, K, 16V	1	
	C4130,31	F1G1C103A116	C 0.010UF, K, 16V	2	

Safety	Ref. No.	Part No.	Part Name & Description	Pcs	Remarks
	C4239	FIJ1A106A043	C 0.010UF, K, 10V	1	
	C4243	FIG1C104A116	C 0.10UF, K, 16V	1	
	C4250,51	FIH1H103A970	C 0.001UF, K, 50V	2	
	C4252	F2G1C470A022	E 47UF, 16V	1	
	C4500,01	FIG1C104A116	C 0.10UF, K, 16V	2	
	C4506,07	FIG1C104A116	C 0.10UF, K, 16V	2	
	C4508,09	FIJ1A106A043	C 0.010UF, K, 10V	2	
	C4510,11	FIG1C104A116	C 0.10UF, K, 16V	2	
	C4513-15	FIG1C104A116	C 0.10UF, K, 16V	3	
	C4517-19	FIG1C104A116	C 0.10UF, K, 16V	3	
	C4520	FIJ1A106A043	C 0.010UF, K, 10V	1	
	C4522	FIH0J1050012	C 1UF, K, 16V	1	
	C4523	F2G0G470A043	C 47UF, 6.3V	1	PAVCA
	C4526-30	FIG1C104A116	C 0.10UF, K, 16V	5	
	C4531	FIH0J1050012	C 1UF, K, 16V	1	
	C4532	FIJ1A106A043	C 0.010UF, K, 10V	1	
	C4626	FIG1C104A116	C 0.10UF, K, 16V	1	
	C4701	FIG1H102A730	C 1000UF, 50V	1	
	C4702	FIG1C104A116	C 0.10UF, K, 16V	1	
	C4703	FIG1H102A730	C 1000UF, 50V	1	
	C4704-08	FIG1C104A116	C 0.10UF, K, 16V	5	
	C4712	FIG1C104A116	C 0.10UF, K, 16V	1	
	C4713,14	FIG1H102A730	C 1000UF, 50V	2	
	C4715	FIG1C104A116	C 0.10UF, K, 16V	1	
	C4716-20	FIG1H102A730	C 1000UF, 50V	5	
	C4721	FIG1C104A116	C 0.10UF, K, 16V	1	
	C4722-25	FIG1H102A730	C 1000UF, 50V	4	
	C4731	FIG1C104A116	C 0.10UF, K, 16V	1	
	C4732-34	FIG1H102A730	C 1000UF, 50V	3	
	C4741	FIG1H102A730	C 1000UF, 50V	1	
	C4742	FIG1C104A116	C 0.10UF, K, 16V	1	
	C4743	FIG1H102A730	C 1000UF, 50V	1	
	C4744,45	FIG1C104A116	C 0.10UF, K, 16V	2	
	C4746	FIG1H102A730	C 1000UF, 50V	1	
	C4751-57	FIG1C104A116	C 0.10UF, K, 16V	7	
	C4761-63	FIH1H103A970	C 0.001UF, K, 50V	3	
	C4771	FIG1H102A730	C 1000UF, 50V	1	
	C4772	FIG1C104A116	C 0.10UF, K, 16V	1	
	C4773	FIG1H102A730	C 1000UF, 50V	1	
	C4775	FIG1C104A116	C 0.10UF, K, 16V	1	
	C4776	FIG1H102A730	C 1000UF, 50V	1	
	C4778-81	FIG1C104A116	C 0.10UF, K, 16V	4	
	C4782	FIG1H102A730	C 1000UF, 50V	1	
	C4785-87	FIG1H102A730	C 1000UF, 50V	3	
	C4795-98	FIG1H102A730	C 1000UF, 50V	4	
	C5408	FIJ1A106A043	C 0.010UF, K, 10V	1	
	C5409	FIG1E103A123	C 0.010UF, K, 25V	1	
	C5410	FIJ1E105A171	C 1 UF 25V	1	
	C5414,15	FIJ1E105A171	C 1 UF 25V	2	
	C5431	FIJ1E105A171	C 1 UF 25V	1	
	C5461	FIH1E104A129	C 0.1UF, 25V	1	
	C5462	FIG1C104A116	C 0.10UF, K, 16V	1	
	C5463	FIK1C1060004	C 0.010UF, 16V	1	
	C5481	FIH1A1050032	C 10UF, 50V	1	
	C5483	FIJ1A106A043	C 0.010UF, K, 10V	1	
	C5486	FIG1C473A081	C 0.047UF, K, 16V	1	
	C5487	FIH1C105A008	C 1UF, K, 16V	1	
	C5488	FIG1C473A081	C 0.047UF, K, 16V	1	
	C5489	FIJ1A106A043	C 0.010UF, K, 10V	1	
	C5492	FIG1C104A116	C 0.10UF, K, 16V	1	
	C5493	FIH1A1050032	C 10UF, 50V	1	
	C5494	FIH1C105A145	C 0.01UF, K, 16V	1	
	C5496	FIH1A1050032	C 10UF, 50V	1	

Safety	Ref. No.	Part No.	Part Name & Description	Pcs	Remarks
	C5497	FIG1C104A116	C 0.10UF, K, 16V	1	
	C5500	FIG1C103A116	C 0.010UF, K, 16V	1	
	C5537	EEH1B1V220P	E 22UF, 35V	1	
	C5538	FIH1H102A970	C 1000PF, K, 50V	1	
	C5539	ECJ3YB1C106M	C 10UF, M,16V	1	
	C5540	FIJ1H474A757	C 0.47UF, 50V	1	
	C5541	FIG1C103A116	C 0.010UF, K, 16V	1	
	C5602	ECGRLOG680ER	C 68UF, J, 4V	1	
	C5603	FIG1C104A116	C 0.10UF, K, 16V	1	
	C5604	FIG1E6820007	C 6800UF, Z, 25V	1	
	C5605	FIJ1A475A039	C 4.7UF, K, 10V	1	
	C5606	FIH1C105A145	C 0.01UF, K, 16V	1	
	C5607	FIG1H221A459	C 220UF, 50V	1	
	C5611,12	FIK1C1060004	C 0.010UF, 16V	2	
	C5615	FIK1C1060004	C 0.010UF, 16V	1	
	C5616	FIG1C273A081	C 0.027UF, K, 16V	1	
	C5618,19	FIK1C1060004	C 0.010UF, 16V	2	
	C5620	FIH1C104A143	C 0.1UF, K, 16V	1	
	C5621	FIG1E103A123	C 0.010UF, K, 25V	1	
	C5622	FIJ1A475A039	C 4.7UF, K, 10V	1	
	C5623	FIG1H221A459	C 220UF, 50V	1	
	C5624	FIG1H471A730	C 470UF, 50V	1	
	C5626,27	FIG1C104A116	C 0.10UF, K, 16V	2	
	C5628,29	ECGRLOG680ER	C 68UF, J, 2.5V	2	
	C5631	F2G1C470A022	E 47UF, 16V	1	
	C5632	FIH1C105A145	C 0.01UF, K, 16V	1	
	C5636-41	FIG1C104A116	C 0.10UF, K, 16V	6	
	C5642	FIK1C1060004	C 0.010UF, 16V	1	
	C5643	FIH1C104A143	C 0.1UF, K, 16V	1	
	C5644	FIH1C105A145	C 0.01UF, K, 16V	1	
	C5645	FIJ1H474A757	C 0.47UF, 50V	1	
	C5651	F2G1A101A170	E 100UF, 10V	1	PAVCA
	C5692,93	FIH1E104A129	C 0.1UF, 25V	2	
	C7045,46	ECJ2FB1E475M	C 4.7UF, K, 25V	2	
	C7048	FIG1H102A730	C 1000UF, 50V	1	
	C7052	EEH1B0G471P	C 470PF, J, 4V	1	
	C7053	ECGRLOG680ER	C 68UF, J, 4V	1	
	C7054	FIJ0J475A035	C 4.7UF, K, 16V	1	
	C7055,56	FIG1C104A116	C 0.10UF, K, 16V	2	
	C7058	FIH0J1050012	C 1UF, K, 16V	1	
	C7059	F2G0G470A043	C 47UF, 6.3V	1	PAVCA
	C7061	FIH0J1050012	C 1UF, K, 16V	1	
	C7062	FIG1C104A116	C 0.10UF, K, 16V	1	
	C7065	FIJ1C474A104	C 0.47UF, Z, 16V	1	
	C8001	FIG1C104A116	C 0.10UF, K, 16V	1	
	C8002-05	FIH0J1050012	C 1UF, K, 16V	4	
	C8006-08	FIG1C104A116	C 0.10UF, K, 16V	3	
	C8009,10	FIJ1A106A043	C 0.010UF, K, 10V	2	
	C8011-14	FIG1C104A116	C 0.10UF, K, 16V	4	
	C8015,16	FIH0J1050012	C 1UF, K, 16V	2	
	C8017	FIJ1A106A043	C 0.010UF, K, 10V	1	
	C8018-21	FIG1C104A116	C 0.10UF, K, 16V	4	
	C8022	FIH0J1050012	C 1UF, K, 16V	1	
	C8023,24	FIJ1A106A043	C 0.010UF, K, 10V	2	
	C8025-29	FIG1C104A116	C 0.10UF, K, 16V	5	
	C8030,31	FIH0J1050012	C 1UF, K, 16V	2	
	C8032	FIJ1A106A043	C 0.010UF, K, 10V	1	
	C8033,34	FIG1C104A116	C 0.10UF, K, 16V	2	
	C8035,36	FIJ1A106A043	C 0.010UF, K, 10V	2	
	C8037-41	FIG1C104A116	C 0.10UF, K, 16V	5	
	C8042	ECGRLOG680ER	C 68UF, J, 4V	1	
	C8043-51	FIG1C104A116	C 0.10UF, K, 16V	9	
	C8052	FIH0J1050012	C 1UF, K, 16V	1	
	C8053	FIG1C103A116	C 0.010UF, K, 16V	1	
	C8056,57	FIG1C104A116	C 0.10UF, K, 16V	2	

Safety	Ref. No.	Part No.	Part Name & Description	Pcs	Remarks
	C8058	F1J1A106A043	C 0.010UF, K, 10V	1	
	C8067	F1G1C103A116	C 0.010UF, K, 16V	1	
	C8068	F1G1C104A116	C 0.10UF, K, 16V	1	
	C8069	F1G1H820A731	C 82UF, 50V	1	
	C8070-74	F1G1C104A116	C 0.10UF, K, 16V	5	
	C8075	F1J0G2260001	C 0.001UF, 6.3V	1	
	C8076-80	F1G1C104A116	C 0.10UF, K, 16V	5	
	C8081	F1G1H102A730	C 1000UF, 50V	1	
	C8301-03	F1G1H221A731	C 220UF, 50V	3	
	C8307	F1G1H102A730	C 1000UF, 50V	1	
	C8308	F1G1H103A735	C 0.01UF, 50V	1	
	C8309	F1G1H102A730	C 1000UF, 50V	1	
	C8310	F1G1C104A116	C 0.10UF, K, 16V	1	
	C8311	F2G1V220A020	E 22UF, 35V	1	
	C8312	F1G1C104A116	C 0.10UF, K, 16V	1	
	C8313,14	EEH0J221UP	C 220PF, J, 6.3V	2	
	C8315,16	F1G1H102A730	C 1000UF, 50V	2	
	C8321	F1G1H121A731	C 120PF, K, 50V	1	PAVCA
	C8322,23	F1G1H102A730	C 1000UF, 50V	2	
	C8324,25	F1G1C104A116	C 0.10UF, K, 16V	2	
	C8326	F1G1C103A116	C 0.010UF, K, 16V	1	
	C8327,28	F1G1C104A116	C 0.10UF, K, 16V	2	
	C8329,30	F1J1A106A043	C 0.010UF, K, 10V	2	
	C8331-35	F1G1C104A116	C 0.10UF, K, 16V	5	
	C8336	F1G1H120A731	C 12UF, 50V	1	
	C8337	F1G1C104A116	C 0.10UF, K, 16V	1	
	C8338	F1G1H150A731	C 15UF, 50V	1	
	C8339-42	F1G1C104A116	C 0.10UF, K, 16V	4	
	C8343	F1H0J1050012	C 1UF, K, 16V	1	
	C8344,45	F1J1A106A043	C 0.010UF, K, 10V	2	
	C8370	F1G1H102A730	C 1000UF, 50V	1	
	C8371	F1H1H104A970	C 0.1UF, K, 50V	1	
	C8372	F1J1A106A043	C 0.010UF, K, 10V	1	
	C8373	F1G1C104A116	C 0.10UF, K, 16V	1	
	C8374,75	F1J1A106A043	C 0.010UF, K, 10V	2	
	C8376	F1G1C103A116	C 0.010UF, K, 16V	1	
	C8377	F1G1C104A116	C 0.10UF, K, 16V	1	
	C8378	F1G1C103A116	C 0.010UF, K, 16V	1	
	C8379	F1G1C104A116	C 0.10UF, K, 16V	1	
	C8380	F1G1H103A735	C 0.01UF, 50V	1	
	C8381	F1G1C104A116	C 0.10UF, K, 16V	1	
	C8382	F1G1C103A116	C 0.010UF, K, 16V	1	
	C8500-04	F1G1C104A116	C 0.10UF, K, 16V	5	
	C8506	F1G1C104A116	C 0.10UF, K, 16V	1	
	C8534	F2G0G470A043	C 47UF, 6.3V	1	PAVCA
	C8537	ECJ2XF1C225Z	C 2.2UF, Z, 16V	1	
	D1002,03	EZJZ0V120JA	VARISTOR	2	
	D1004-07	EZAEG2A50AX	DIODE	4	
	D2318,19	MA2J11100L	DIODE	2	
	D2500A	B3AAB0000343	LED	1	PAVCA
	D3001,02	EZJP0V080GA	VARISTOR	2	
	D3013-15	EZJP0V080GA	VARISTOR	3	
	D3023	EZJP0V080GA	VARISTOR	1	
	D3025-27	EZJP0V080GA	VARISTOR	3	
	D3050	K7AAAY000005	PHOTO LINK	1	
	D3064,65	EZJP0V080GA	VARISTOR	2	
	D3101-03	EZJP0V080GA	VARISTOR	3	
	D3113,14	EZJP0V080GA	VARISTOR	2	
	D3201	MA2J11100L	DIODE	1	
	D3202	MA2J72800L	ZENER DIODE	1	
	D3701-03	EZJP0V080GA	VARISTOR	3	
	D4000	MA2J72800L	ZENER DIODE	1	
	D4001-03	MA2J11100L	DIODE	3	
	D4005	MA2J72800L	ZENER DIODE	1	

Safety	Ref. No.	Part No.	Part Name & Description	Pcs	Remarks
	D4101,02	EZJZ0V120JA	VARISTOR	2	
	D4502-12	EZAEG2A50AX	DIODE	11	
	D4513	BOBC5R6A0275	DIODE	1	
	D4514	EZAEG2A50AX	DIODE	1	
	D4515	BOBC5R6A0275	DIODE	1	
	D4516-23	EZAEG2A50AX	DIODE	8	
	D4524-27	BOHCMM000014	DIODE	4	
	D4628	EZAEG2A50AX	DIODE	1	
	D5407	MA2J11100L	DIODE	1	
	D5414	MA2J11100L	DIODE	1	
	D5415	MA3X78900L	ZENER DIODE	1	
	D5416	BOBC03900015	ZENER DIODE	1	
	D5612	MAZ80470ML	ZENER DIODE	1	
	D5613	MA2J11100L	DIODE	1	
	D5618	MAZ80470ML	ZENER DIODE	1	
	D5619	MA2J11100L	DIODE	1	
	D5626	MAZ80470ML	ZENER DIODE	1	
	D5627	MA2J11100L	DIODE	1	
	D5652	MA8039MTX	DIODE	1	
	D5653	B0JCPD000026	DIODE	1	
	D5711,12	MA2J11100L	DIODE	2	
	D5713	MAZ81800ML	ZENER DIODE	1	
	D5714	MA2J11100L	DIODE	1	
	D5715	MAZ81100ML	ZENER DIODE	1	
	D5716	MA2J11100L	DIODE	1	
	D7084	MAZ82400ML	DIODE	1	
	D7085	MA2J11100L	DIODE	1	
	FL4031,32	JOHAYY000011	LC FILTER	2	PAVCA
	FL4035	JOHAYY000011	LC FILTER	1	PAVCA
	FL4201-03	EXC28CE201U	NW_R(X4)	3	
	IC2301	C1AB00003012	IC	1	
	IC3100	C0JBAB000408	IC	1	
	IC3200	MFI341S2161	IC	1	
	IC3201	C0DBEY000016	IC	1	
	IC3202	C0ABBB000230	IC	1	
	IC4001	C0EBF0000354	IC	1	
	IC4003	C5ZBZ0000067	IC	1	PAVCA
	IC4004	TVRQ607S	IC	1	PAVCA
	IC4005	TVRQ530S	IC	1	PAVCA
	IC4007,08	C0JBAZ002261	IC	2	
	IC4500	TVRQ524S	IC	1	PAVCA
	IC4501	TVRQ525S	IC	1	PAVCA
	IC4503	C1AB00003106	IC	1	PAVCA
	IC4504	TVRQ526S	IC	1	PAVCA
	IC4506	C0CBCYE00001	IC	1	
	IC5405	C0DBEY000016	IC	1	
	IC5409	C0DBEHE00005	IC	1	
	IC5480	C1ZBZ0003986	IC	1	
	IC5481	C0DBAJB00004	IC	1	
	IC5600,01	C0DBAYY00480	IC	2	
	IC7005	C0DBAFG00018	IC	1	
	IC7006	C0CBCYE00001	IC	1	
	IC8001	MN2WS0047	IC	1	
	IC8002	C3ABSY000036	IC	1	
	IC8004	C0ZBZ0001030	IC	1	
	IC8300	MN88436	IC	1	PAVCA
	IC8502	TVRQ531ABS	IC	1	PAVCA
	IC8503	TVRQ606S	IC	1	PAVCA
	JK3001	K4AK17A00001	TERMINAL BOARD	1	PAVCA
	JK3104	K1FB315A0006	CONNECTOR	1	
	JK4500,01	K1FY119D0006	CONNECTOR	2	
	JK4800	K4AK16B00001	TERMINAL BOARD	1	
	JK8302	K1NA09E00080	9P CONNECTOR	1	
	JS2501	D0YAR0000007	M 0 OHM 1/4W	1	
	JS3078	D0YAR0000007	M 0 OHM 1/4W	1	
	L2309	G1C330MA0291	INDUCTION COIL	1	
	L2313	G1C330MA0291	INDUCTION COIL	1	
	L2331	G1C330MA0291	INDUCTION COIL	1	

Safety	Ref. No.	Part No.	Part Name & Description	Pcs	Remarks
	L2335	G1C330MA0291	INDUCTION COIL	1	
	L2843	J0JCC0000059	CHIP INDUCTOR	1	
	L3201	J0JHC0000045	CHIP INDUCTOR	1	
	L4002-13	J0JHC0000045	CHIP INDUCTOR	12	
	L4014	J0JHC0000117	CHIP INDUCTOR	1	
	L4201	J0JYC0000068	CHIP INDUCTOR	1	
	L4210	J0JHC0000045	CHIP INDUCTOR	1	
	L4502-07	J0JHC0000117	CHIP INDUCTOR	6	
	L4508	J0JHC0000045	CHIP INDUCTOR	1	
	L4606	J0JHC0000045	CHIP INDUCTOR	1	
	L5430	J0JHC0000096	CHIP INDUCTOR	1	
	L5480	J0JYC0000068	CHIP INDUCTOR	1	
	L5483	G1C470MA0077	INDUCTION COIL	1	
	L5484	G1C100MA0072	INDUCTION COIL	1	
	L5600	G1C4R7Z00014	INDUCTION COIL	1	
	L5601	G1C3R3Z00004	INDUCTION COIL	1	
	L5602	G1C2R2Z00007	INDUCTION COIL	1	
	L5604	G1C100MA0203	INDUCTION COIL	1	
	L5605	J0JHC0000045	CHIP INDUCTOR	1	
	L5608	G1C100MA0077	INDUCTION COIL	1	
	L7006	G1C100MA0203	INDUCTION COIL	1	
	L7007	G1C6R3ZA0156	INDUCTION COIL	1	
	L8001-05	J0JHC0000045	CHIP INDUCTOR	5	
	L8007-10	J0JHC0000045	CHIP INDUCTOR	4	
	L8111,12	DOYAR0000007	M 0 OHM 1/4W	2	
	L8300-02	J0JHC0000045	CHIP INDUCTOR	3	
	L8303,04	G1CR39JA0020	INDUCTION COIL	2	PAVCA
	L8305	G1CR10JA0020	INDUCTION COIL	1	PAVCA
	L8306-09	J0JHC0000045	CHIP INDUCTOR	4	
	L8500	J0JHC0000075	CHIP INDUCTOR	1	
	PA4201	ERBSE2R50U	FUSE	1	
	PA5400	K5H1622A0023	FUSE	1	
	PA5601	ERBSE2R50U	FUSE	1	
	Q2101	B1ABCF000231	TRANSISTOR	1	
	Q2106	B1ABCF000231	TRANSISTOR	1	
	Q2350	B1ABCF000231	TRANSISTOR	1	
	Q2500	B1ABCF000231	TRANSISTOR	1	
	Q2504	B1ABCF000231	TRANSISTOR	1	
	Q3201-04	B1ABCF000231	TRANSISTOR	4	
	Q3205,06	B1ADCE000022	TRANSISTOR	2	
	Q3207,08	B1ABCF000231	TRANSISTOR	2	
	Q4000	B1ADCE000022	TRANSISTOR	1	
	Q4004,05	B1ABCF000231	TRANSISTOR	2	
	Q4007	B1ABCF000231	TRANSISTOR	1	
	Q4201	B1ABCF000231	TRANSISTOR	1	
	Q4202	B1ADCE000022	TRANSISTOR	1	
	Q4203	B1ABCF000231	TRANSISTOR	1	
	Q4205	B1ABCF000231	TRANSISTOR	1	
	Q4502,03	B1ABCF000231	TRANSISTOR	2	
	Q5407,08	B1ABCF000231	TRANSISTOR	2	
	Q5412	B1CHRE000005	TRANSISTOR	1	
	Q5431	B1ABCF000231	TRANSISTOR	1	
	Q5432	B1CFNG000001	FET	1	
	Q5433	2SB0709ASL	TRANSISTOR	1	
	Q5434	2SD0601ASL	TRANSISTOR	1	
	Q5600-02	B1MBDDA00003	FET	3	
	Q8300	2SB0709ASL	TRANSISTOR	1	
	R2101	ERJ2GED563X	M 56KOHM ,J,0.063W	1	
	R2102	ERJ2GEJ103	M 10KOHM, J,0.063W	1	
	R2103	ERJ2GEJ104	M 100KOHM, J,0.063W	1	
	R2302	D1BB8062A055	M8.06KOHM, 1/10W	1	PAVCA
	R2303,04	ERJ3EKF2212	M 22KOHM, 1/16W	2	
	R2350,51	ERJ2GEJ103	M 10KOHM, J,0.063W	2	
	R2352	ERJ2GEJ473	M 47KOHM, J,0.063W	1	
	R2353,54	DOYAR0000007	M 0 OHM 1/4W	2	

Safety	Ref. No.	Part No.	Part Name & Description	Pcs	Remarks
	R2355	ERJ2GEJ223	M 22KOHM, J,0.063W	1	
	R2502	ERJ2GEJ473	M 47KOHM, J,0.063W	1	
	R2504	ERJ2GEJ223	M 22KOHM, J,0.063W	1	
	R2509	ERJ2RKF6040X	M 604 OHM, 0.063W	1	PAVCA
	R2512	ERJ2GEJ470	M 47 OHM, J,0.063W	1	
	R2516	ERJ2GEJ473	M 47KOHM, J,0.063W	1	
	R2517	ERJ2GEJ104	M 100KOHM, J,0.063W	1	
	R2518	ERJ2GEJ103	M 10KOHM, J,0.063W	1	
	R3101-03	ERJ6RED750	M 75 OHM, 1/10W	3	
	R3113,14	ERJ2GEJ472	M 4.7KOHM, J,0.063W	2	
	R3115	ERJ2GEJ101	M 100 OHM, J,0.063W	1	
	R3116,17	ERJ2GEJ220	M 22 OHM, J,0.063W	2	
	R3123	ERJ6RED750	M 75 OHM, 1/10W	1	
	R3154	DOYAR0000007	M 0 OHM 1/4W	1	
	R3155	ERJ2GEJ560X	M 56 OHM, J,0.063W	1	
	R3157	DOYAR0000007	M 0 OHM 1/4W	1	
	R3159	ERJ6RED750	M 75 OHM, 1/10W	1	
	R3160,61	ERJ2GEJ184	M 180KOHM, J,0.063W	2	
	R3164,65	ERJ2GEJ184	M 180KOHM, J,0.063W	2	
	R3172,73	ERJ2GEJ184	M 180KOHM, J,0.063W	2	
	R3174	ERJ2GEJ103	M 10KOHM, J,0.063W	1	
	R3175,76	ERJ6RED750	M 75 OHM, 1/10W	2	
	R3178	ERJ6RED750	M 75 OHM, 1/10W	1	
	R3200,01	ERJ2GEJ220	M 22 OHM, J,0.063W	2	
	R3202	ERJ2GEJ221	M 220 OHM, J,0.063W	1	
	R3203	ERJ2GEJ101	M 100 OHM, J,0.063W	1	
	R3204	DOYAR0000007	M 0 OHM 1/4W	1	
	R3205	ERJ2GEJ101	M 100 OHM, J,0.063W	1	
	R3206,07	ERJ2GEJ221	M 220 OHM, J,0.063W	2	
	R3208	ERJ6RED750	M 75 OHM, 1/10W	1	
	R3209,10	ERJ2GEJ184	M 180KOHM, J,0.063W	2	
	R3211	ERJ2RKD2203X	M 220KOHM, 0.063W	1	PAVCA
	R3213	ERJ2RKD3303X	M 330KOHM, 0.063W	1	PAVCA
	R3214	ERJ2RKF1021X	M 1.02KOHM, 0.063W	1	PAVCA
	R3215	ERJ2RKF3241X	M 3.24KOHM, 0.063W	1	PAVCA
	R3216	ERJ2GEJ103	M 10KOHM, J,0.063W	1	
	R3217	ERJ2GEJ473	M 47KOHM, J,0.063W	1	
	R3218	ERJ2GEJ103	M 10KOHM, J,0.063W	1	
	R3219	ERJ2GEJ472	M 4.7KOHM, J,0.063W	1	
	R3220,21	ERJ3EKF1502	M 15KOHM, 1/16W	2	
	R3222-25	D1BB1002A055	M 10KOHM, 1/10W	4	
	R3226,27	ERJ3EKF1502	M 15KOHM, 1/16W	2	
	R3228,29	ERJ2GEJ103	M 10KOHM, J,0.063W	2	
	R3233,34	ERJ2GEJ472	M 4.7KOHM, J,0.063W	2	
	R3235,36	ERJ2GEJ473	M 47KOHM, J,0.063W	2	

Safety	Ref. No.	Part No.	Part Name & Description	Pcs	Remarks
	R3237,38	ERJ2GEJ104	M 100KOHM, J,0.063W	2	
	R3239,40	ERJ2GEJ564	M 560KOHM, J,0.063W	2	
	R3241,42	ERJ2GEJ472	M 4.7KOHM, J,0.063W	2	
	R3243	ERJ2GEJ103	M 10KOHM, J,0.063W	1	
	R3244	ERJ2GEJ473	M 47KOHM, J,0.063W	1	
	R3245	ERJ2GEJ103	M 10KOHM, J,0.063W	1	
	R3246	ERJ2GEJ101	M 100 OHM, J,0.063W	1	
	R3247	ERJ2GEJ473	M 47KOHM, J,0.063W	1	
	R3249	ERJ2GEJ221	M 220 OHM, J,0.063W	1	
	R3252	ERJ2GEJ103	M 10KOHM, J,0.063W	1	
	R3701,02	ERJ6RED750	M 75 OHM, 1/10W	2	
	R4000	ERJ2GEJ104	M 100KOHM, J,0.063W	1	
	R4001	ERJ2GEJ103	M 10KOHM, J,0.063W	1	
	R4002	ERJ2GED563X	M 56KOHM, J,0.063W	1	
	R4004	ERJ2GED563X	M 56KOHM, J,0.063W	1	
	R4006	ERJ2GEJ103	M 10KOHM, J,0.063W	1	
	R4007	ERJ2GEJ561	M 60 OHM, J,0.063W	1	
	R4010	ERJ2GEJ474	M 470KOHM, J,0.063W	1	
	R4011	ERJ2GEJ101	M 100 OHM, J,0.063W	1	
	R4012	ERJ2GEJ474	M 470KOHM, J,0.063W	1	
	R4014	ERJ2GEJ101	M 100 OHM, J,0.063W	1	
	R4021-24	D1BB1802A055	M 18KOHM, 1/10W	4	
	R4028,29	D1BB1802A055	M 18KOHM, 1/10W	2	
	R4030	D1BB1001A055	M 1KOHM, 1/16W	1	
	R4033	ERJ2GEJ101	M 100 OHM, J,0.063W	1	
	R4037	ERJ2RKF20R0X	M 20 OHM, , 0.063W	1	PAVCA
	R4038	ERJ3EKF57R6V	M 57.6OHM, 1/16W	1	PAVCA
	R4039	ERJ2GEJ101	M 100 OHM, J,0.063W	1	
	R4041-46	ERJ2RKF20R0X	M 20 OHM, , 0.063W	6	PAVCA
	R4047	ERJ2GEJ560X	M 56 OHM, J,0.063W	1	
	R4048	ERJ2RKF20R0X	M 20 OHM, , 0.063W	1	PAVCA
	R4050-52	ERJ3EKF57R6V	M 57.6OHM, 1/16W	3	PAVCA
	R4055	D1BB7151A055	M 7.15KOHM, 1/10W	1	
	R4056	ERJ2GEJ102X	M 1K OHM J 1/4W	1	
	R4057	ERJ2GEJ221	M 220 OHM, J,0.063W	1	
	R4058	ERJ2GEJ473	M 47KOHM, J,0.063W	1	
	R4059	ERJ2GEJ221	M 220 OHM, J,0.063W	1	
	R4060	ERJ2GEJ102X	M 1K OHM J 1/4W	1	
	R4061	ERJ2GEJ220	M 22 OHM, J,0.063W	1	
	R4062	ERJ2GEJ222	M 2.2KOHM, J,0.063W	1	
	R4064	ERJ2RKF2490X	M 249 OHM, 0.063W	1	PAVCA
	R4065	ERJ2GEJ102X	M 1K OHM J 1/4W	1	
	R4066	ERJ2GEJ750	M 75 OHM, J,0.063W	1	
	R4067-72	ERJ2GEJ220	M 22 OHM, J,0.063W	6	
	R4073	EXB28V680JX	RESISTOR ARRAY	1	

Safety	Ref. No.	Part No.	Part Name & Description	Pcs	Remarks
	R4074	ERJ2GEJ220	M 22 OHM, J,0.063W	1	
	R4075	ERJ2GEJ473	M 47KOHM, J,0.063W	1	
	R4076	ERJ2GEJ220	M 22 OHM, J,0.063W	1	
	R4077	ERJ2GEJ473	M 47KOHM, J,0.063W	1	
	R4078	ERJ2GEJ220	M 22 OHM, J,0.063W	1	
	R4079	ERJ2GEJ473	M 47KOHM, J,0.063W	1	
	R4080	ERJ2GEJ220	M 22 OHM, J,0.063W	1	
	R4081	ERJ2GEJ473	M 47KOHM, J,0.063W	1	
	R4082	ERJ2GEJ220	M 22 OHM, J,0.063W	1	
	R4083	EXB2HV473JV	RESISTOR ARRAY	1	
	R4084	ERJ2GEJ102X	M 1K OHM J 1/4W	1	
	R4085	ERJ2GED273X	M 27KOHM, J,0.063W	1	
	R4086,87	ERJ2GEJ220	M 22 OHM, J,0.063W	2	
	R4088	ERJ2GEJ104	M 100KOHM, J,0.063W	1	
	R4091,92	ERJ2GEJ473	M 47KOHM, J,0.063W	2	
	R4093,94	ERJ2GEJ220	M 22 OHM, J,0.063W	2	
	R4096	ERJ2GEJ473	M 47KOHM, J,0.063W	1	
	R4098,99	ERJ2GEJ473	M 47KOHM, J,0.063W	2	
	R4101	ERJ2GEJ473	M 47KOHM, J,0.063W	1	
	R4102	ERJ2GEJ103	M 10KOHM, J,0.063W	1	
	R4103-07	ERJ2GEJ473	M 47KOHM, J,0.063W	5	
	R4108	EXB2HV473JV	RESISTOR ARRAY	1	
	R4110,11	ERJ2GEJ103	M 10KOHM, J,0.063W	2	
	R4113-16	ERJ2GEJ101	M 100 OHM, J,0.063W	4	
	R4117	EXB2HV101J	RESISTOR ARRAY	1	
	R4118-21	ERJ2GEJ220	M 22 OHM, J,0.063W	4	
	R4122,23	EXB2HV101J	RESISTOR ARRAY	2	
	R4124	EXB2HV220JV	RESISTOR ARRAY	1	
	R4125	ERJ2GEJ473	M 47KOHM, J,0.063W	1	
	R4127	ERJ2GEJ473	M 47KOHM, J,0.063W	1	
	R4128-30	ERJ2GEJ103	M 10KOHM, J,0.063W	3	
	R4131	ERJ2GEJ220	M 22 OHM, J,0.063W	1	
	R4132	ERJ2GEJ103	M 10KOHM, J,0.063W	1	
	R4133	ERJ2GEJ473	M 47KOHM, J,0.063W	1	
	R4134,35	ERJ2GEJ220	M 22 OHM, J,0.063W	2	
	R4136	ERJ2GEJ562	M 5.6KOHM, J,0.063W	1	
	R4137	ERJ2GEJ103	M 10KOHM, J,0.063W	1	
	R4138	ERJ2GEJ562	M 5.6KOHM, J,0.063W	1	
	R4139,40	ERJ2GEJ103	M 10KOHM, J,0.063W	2	
	R4143,44	D1BB1802A055	M 18KOHM, 1/10W	2	
	R4145	ERJ2GEJ220	M 22 OHM, J,0.063W	1	
	R4148	ERJ2GEJ331	M 330 OHM, J,0.063W	1	
	R4149	ERJ2GEJ473	M 47KOHM, J,0.063W	1	

Safety	Ref. No.	Part No.	Part Name & Description	Pcs	Remarks
	R4150	ERJ2GEJ331	M 330 OHM, J,0.063W	1	
	R4151	ERJ2GEJ223	M 22KOHM, J,0.063W	1	
	R4152	ERJ2GEJ683	M 68KOHM, J,0.063W	1	
	R4153,54	D1BB8201A055	M 8.2KOHM, 1/10W	2	
	R4155	ERJ2GED563X	M 56KOHM, J,0.063W	1	
	R4156	D1BB8201A055	M 8.2KOHM, 1/10W	1	
	R4157	ERJ2GEJ333	M 33KOHM, J,0.063W	1	
	R4158	ERJ2RKF20R0X	M 20 OHM, , 0.063W	1	PAVCA
	R4160	ERJ2GEJ103	M 10KOHM, J,0.063W	1	
	R4161	ERJ2RKF20R0X	M 20 OHM, , 0.063W	1	PAVCA
	R4162	ERJ2GEJ473	M 47KOHM, J,0.063W	1	
	R4167-71	D1BB8201A055	M 8.2KOHM, 1/10W	5	
	R4172,73	ERJ2RKF20R0X	M 20 OHM, , 0.063W	2	PAVCA
	R4174	ERJ2GEJ473	M 47KOHM, J,0.063W	1	
	R4218	DOYAR0000007	M 0 OHM 1/4W	1	
	R4305	ERJ2GEJ473	M 47KOHM, J,0.063W	1	
	R4309	ERJ2GEJ103	M 10KOHM, J,0.063W	1	
	R4310	ERJ2GEJ102X	M 1K OHM J 1/4W	1	
	R4311	ERJ2GEJ473	M 47KOHM, J,0.063W	1	
	R4312	ERJ2GEJ302	M 3KOHM, J,0.063W	1	
	R4315,16	ERJ2GEJ102X	M 1K OHM J 1/4W	2	
	R4317	ERJ2GEJ103	M 10KOHM, J,0.063W	1	
	R4320	ERJ2GEJ103	M 10KOHM, J,0.063W	1	
	R4323	ERJ2GEJ473	M 47KOHM, J,0.063W	1	
	R4325	D1BD4871A044	M 4.87KOHM, 1/10W	1	
	R4327	ERJ2RHD272	M 2.7KOHM, J, 2W	1	
	R4330	ERJ2GEJ100	M 10 OHM, J,0.063W	1	
	R4349	ERJ2GEJ220	M 22 OHM, J,0.063W	1	
	R4358	ERJ2GEJ912	M 9.1KOHM, J,0.063W	1	
	R4359	ERJ2GEJ332	M 3.3KOHM, J,0.063W	1	
	R4360	DOYAR0000007	M 0 OHM 1/4W	1	
	R4404,05	ERJ2GEJ101	M 100 OHM, J,0.063W	2	
	R4500,01	ERJ2GEJ103	M 10KOHM, J,0.063W	2	
	R4502,03	ERJ2GEJ220	M 22 OHM, J,0.063W	2	
	R4528	ERJ2GEJ103	M 10KOHM, J,0.063W	1	
	R4529	ERJ2GEJ472	M 4.7KOHM, J,0.063W	1	
	R4530	ERJ2GEJ103	M 10KOHM, J,0.063W	1	
	R4531	ERJ2GEJ472	M 4.7KOHM, J,0.063W	1	
	R4532,33	ERJ2GEJ103	M 10KOHM, J,0.063W	2	
	R4535,36	ERJ2GEJ472	M 4.7KOHM, J,0.063W	2	
	R4538	ERJ2GEJ473	M 47KOHM, J,0.063W	1	
	R4539	ERJ2GEJ680	M 68 OHM, J,0.063W	1	
	R4540	ERJ2GEJ473	M 47KOHM, J,0.063W	1	
	R4541-43	ERJ2GEJ680	M 68 OHM, J,0.063W	3	

Safety	Ref. No.	Part No.	Part Name & Description	Pcs	Remarks
	R4552	ERJ2GEJ220	M 22 OHM, J,0.063W	1	
	R4561	ERJ2GEJ473	M 47KOHM, J,0.063W	1	
	R4564,65	ERJ2GEJ220	M 22 OHM, J,0.063W	2	
	R4567	D1BB4701A055	M 4.7KOHM, 1/10W	1	
	R4570	D1BB3832A055	M38.3KOHM, 1/10W	1	PAVCA
	R4571	D1BB2202A055	M 22KOHM, 1/10W	1	
	R4616,17	ERJ2GEJ332	M 3.3KOHM, J,0.063W	2	
	R4620-23	ERJ2GEJ220	M 22 OHM, J,0.063W	4	
	R4651,52	ERJ2GEJ102X	M 1K OHM J 1/4W	2	
	R4710	ERJ2GEJ220	M 22 OHM, J,0.063W	1	
	R4716	DOYAR0000007	M 0 OHM 1/4W	1	
	R5058	ERJ2GEJ103	M 10KOHM, J,0.063W	1	
	R5069	ERJ2GEJ103	M 10KOHM, J,0.063W	1	
	R5137,38	ERJ2GEJ103	M 10KOHM, J,0.063W	2	
	R5401	ERJ2RKF1001	M 1KOHM, 0.063W	1	
	R5402	ERJ2RKF3001	M 3KOHM, 0.063W	1	
	R5407	ERJ2GEJ103	M 10KOHM, J,0.063W	1	
	R5408	ERJ2GEJ473	M 47KOHM, J,0.063W	1	
	R5409	ERJ2GEJ103	M 10KOHM, J,0.063W	1	
	R5410	ERJ2GEJ472	M 4.7KOHM, J,0.063W	1	
	R5414	ERJ2RKF6342	M 63.4KOHM, 0.063W	1	
	R5415	ERJ2RKF1002	M 10KOHM, 0.063W	1	
	R5431	ERJ2GEJ103	M 10KOHM, J,0.063W	1	
	R5432	ERJ2GEJ473	M 47KOHM, J,0.063W	1	
	R5433	ERJ2GEJ333	M 33KOHM, J,0.063W	1	
	R5434	ERJ2GEJ223	M 22KOHM, J,0.063W	1	
	R5435	ERJ12YJ471	M 470OHM, J, 1/2W	1	
	R5461	DOYAR0000007	M 0 OHM 1/4W	1	
	R5480	ERJ2GEJ473	M 47KOHM, J,0.063W	1	
	R5483	ERJ2GED563X	M 56KOHM, J,0.063W	1	
	R5484	ERJ2GEJ203X	M 20KOHM, J,0.063W	1	
	R5486,87	ERJ2GEJ473	M 47KOHM, J,0.063W	2	
	R5488	ERJ2GEJ183	M 18KOHM, J,0.063W	1	
	R5489	ERJ2GEJ333	M 33KOHM, J,0.063W	1	
	R5490	ERJ2GEJ472	M 4.7KOHM, J,0.063W	1	
	R5491	ERJ2GEJ473	M 47KOHM, J,0.063W	1	
	R5492	ERJ2GEJ680	M 68 OHM, J,0.063W	1	
	R5493	ERJ2GEJ223	M 22KOHM, J,0.063W	1	
	R5494	ERJ2GEJ683	M 68KOHM, J,0.063W	1	
	R5495	ERJ6GEYJ331V	M 330 OHM J 1/10W	1	
	R5496	ERJ6ENF8202	M 82KOHM, 1/10W	1	
	R5497	D1BD1602A044	M 16KOHM, 1/10W	1	
	R5498	ERJ6GEY0R00V	M 0 OHM J 1/10W	1	
	R5499	ERJ2GEJ472	M 4.7KOHM, J,0.063W	1	
	R5500	ERJ2GEJ473	M 47KOHM, J,0.063W	1	
	R5506	ERJ2GEJ473	M 47KOHM, J,0.063W	1	

Safety	Ref. No.	Part No.	Part Name & Description	Pcs	Remarks
	R5507	ERJ2GEJ472	M 4.7KOHM, J,0.063W	1	
	R5508	D0GBR00Z0002	M 0 OHM J 1/16W	1	
	R5603	D1BB2002A055	M 20KOHM, 1/10W	1	
	R5604	D1BB4752A055	M47.5KOHM, 1/10W	1	
	R5605	D1BB2702A055	M 27KOHM, 1/10W	1	
	R5610	ERJ2GEJ5R6X	M 5.6 OHM, J,0.063W	1	
	R5620	ERJ2GEJ680	M 68 OHM, J,0.063W	1	
	R5629	D1BB2702A055	M 27KOHM, 1/10W	1	
	R5630	D1BB2402A055	M 24KOHM, 1/10W	1	
	R5631	D1BB5102A055	M 51KOHM, 1/10W	1	
	R5632	D1BB3002A055	M 30KOHM, 1/10W	1	
	R5633,34	D1BB1602A055	M 16KOHM, 1/10W	2	
	R5635	ERJ2GEJ5R6X	M 5.6 OHM, J,0.063W	1	
	R5718	DOYAR0000007	M 0 OHM 1/4W	1	
	R5719	ERJ2GEJ103	M 10KOHM, J,0.063W	1	
	R5720	ERJ2GEJ153	M 15KOHM, J,0.063W	1	
	R5762	ERJ2GEJ101	M 100 OHM, J,0.063W	1	
	R7029	ERJ2GEJ103	M 10KOHM, J,0.063W	1	
	R7035	ERJ2GEJ101	M 100 OHM, J,0.063W	1	
	R7037	D1BB1302A055	M 13KOHM, 1/10W	1	
	R7038	D1BB1002A055	M 10KOHM, 1/10W	1	
	R7040	D1BB3832A055	M38.3KOHM, 1/10W	1	PAVCA
	R7041	D1BB2202A055	M 22KOHM, 1/10W	1	
	R7042	ERJ2GEJ103	M 10KOHM, J,0.063W	1	
	R7043	D0GBR00Z0002	M 0 OHM J 1/16W	1	
	R8001	ERJ2GEJ221	M 220 OHM, J,0.063W	1	
	R8002	ERJ2GEJ560X	M 56 OHM, J,0.063W	1	
	R8004	D1BB2402A055	M 24KOHM, 1/10W	1	
	R8005	ERJ2GEJ103	M 10KOHM, J,0.063W	1	
	R8006	ERJ2RHD682X	M 6.8KOHM, J, 2W	1	
	R8030	ERJ2GEJ101	M 100 OHM, J,0.063W	1	
	R8031,32	D1BB2700A055	M 270 OHM, 1/10W	2	
	R8056-73	ERJ2GEJ470	M 47 OHM, J,0.063W	18	
	R8074	ERJ2GEJ221	M 220 OHM, J,0.063W	1	
	R8075-78	ERJ2GEJ470	M 47 OHM, J,0.063W	4	
	R8081	ERJ2GEJ103	M 10KOHM, J,0.063W	1	
	R8082	ERJ2RKF75R0	M 75 OHM, , 0.063W	1	
	R8083	ERJ2GEJ301	M 300 OHM, J,0.063W	1	
	R8086	ERJ2GEJ104	M 100KOHM, J,0.063W	1	
	R8087	ERJ2GEJ103	M 10KOHM, J,0.063W	1	
	R8090	ERJ2GEJ103	M 10KOHM, J,0.063W	1	
	R8091	ERJ2GEJ470	M 47 OHM, J,0.063W	1	
	R8093	ERJ2GEJ470	M 47 OHM, J,0.063W	1	
	R8094	ERJ2GEJ103	M 10KOHM, J,0.063W	1	
	R8097	ERJ2GEJ221	M 220 OHM, J,0.063W	1	
	R8098,99	ERJ2GEJ103	M 10KOHM, J,0.063W	2	
	R8100	ERJ2GEJ470	M 47 OHM, J,0.063W	1	
	R8101	ERJ2GEJ103	M 10KOHM, J,0.063W	1	

Safety	Ref. No.	Part No.	Part Name & Description	Pcs	Remarks
	R8106	ERJ2GEJ202	M 2KOHM, J,0.063W	1	
	R8107	ERJ2GEJ101	M 100 OHM, J,0.063W	1	
	R8108	ERJ2GEJ333	M 33KOHM, J,0.063W	1	
	R8110	ERJ2GEJ103	M 10KOHM, J,0.063W	1	
	R8116	ERJ2GEJ220	M 22 OHM, J,0.063W	1	
	R8300,01	D0GBR00Z0002	M 0 OHM J 1/16W	2	
	R8302,03	ERJ2GEJ470	M 47 OHM, J,0.063W	2	
	R8304	DOYAR0000007	M 0 OHM 1/4W	1	
	R8305	D0GBR00Z0002	M 0 OHM J 1/16W	1	
	R8307,08	D0GBR00Z0002	M 0 OHM J 1/16W	2	
	R8309,10	DOYAR0000007	M 0 OHM 1/4W	2	
	R8311	D0GDR00Z0002	M 0 OHM, 1/10W	1	
	R8312,13	DOYAR0000007	M 0 OHM 1/4W	2	
	R8314	ERJ2GEJ221	M 220 OHM, J,0.063W	1	
	R8316	ERJ2GEJ471	M 470 OHM, J,0.063W	1	
	R8317	ERJ6GEJ102V	M 1K OHM J 1/10W	1	
	R8318	ERJ2GEJ102X	M 1K OHM J 1/4W	1	
	R8319	D1BB1002A055	M 10KOHM, 1/10W	1	
	R8321	ERJ2GEJ222	M 2.2KOHM, J,0.063W	1	
	R8323	ERJ2GEJ221	M 220 OHM, J,0.063W	1	
	R8324	ERJ2GEJ222	M 2.2KOHM, J,0.063W	1	
	R8326	ERJ2GEJ103	M 10KOHM, J,0.063W	1	
	R8327	ERJ2GEJ473	M 47KOHM, J,0.063W	1	
	R8328	ERJ2GEJ101	M 100 OHM, J,0.063W	1	
	R8329	ERJ2GEJ220	M 22 OHM, J,0.063W	1	
	R8330	ERJ2GEJ470	M 47 OHM, J,0.063W	1	
	R8332	ERJ2GEJ470	M 47 OHM, J,0.063W	1	
	R8333	ERJ2GEJ220	M 22 OHM, J,0.063W	1	
	R8334,35	ERJ2GEJ470	M 47 OHM, J,0.063W	2	
	R8336	DOYAR0000007	M 0 OHM 1/4W	1	
	R8337	ERJ2GEJ220	M 22 OHM, J,0.063W	1	
	R8338	ERJ2GEJ473	M 47KOHM, J,0.063W	1	
	R8504	ERJ2GEJ103	M 10KOHM, J,0.063W	1	
	R8505-07	EXB2HV560JV	RESISTOR ARRAY	3	
	R8508	EXB2HV473JV	RESISTOR ARRAY	1	
	R8509,10	EXB2HV560JV	RESISTOR ARRAY	2	
	R8512	ERJ2GEJ103	M 10KOHM, J,0.063W	1	
	R8517-20	ERJ2RKD330	M 33 OHM, J, 2W	4	
	R8528-30	ERJ2GEJ560X	M 56 OHM, J,0.063W	3	
	R8532	ERJ2GEJ560X	M 56 OHM, J,0.063W	1	
	R8540-45	ERJ2GEJ220	M 22 OHM, J,0.063W	6	
	R8546-48	ERJ2GEJ332	M 3.3KOHM, J,0.063W	3	
	R8550	ERJ2GEJ332	M 3.3KOHM, J,0.063W	1	
	R8552,53	ERJ2GEJ332	M 3.3KOHM, J,0.063W	2	
	R8554,55	ERJ2GEJ220	M 22 OHM, J,0.063W	2	
	R8556	ERJ2GEJ103	M 10KOHM, J,0.063W	1	
	R8557,58	ERJ2GEJ332	M 3.3KOHM, J,0.063W	2	

Safety	Ref. No.	Part No.	Part Name & Description	Pcs	Remarks
	R8559	ERJ2GEJ560X	M 56 OHM, J,0.063W	1	
	R8566	EXB2HV103JV	RESISTOR ARRAY	1	
	R8571	ERJ2RKD330	M 33 OHM, J, 2W	1	
	R8572	EXB28V330J	RESISTOR ARRAY	1	
	R8573	EXB28V121JX	RESISTOR ARRAY	1	
	R8574	ERJ2GEJ680	M 68 OHM, J,0.063W	1	
	R8575	ERJ2GEJ221	M 220 OHM, J,0.063W	1	
	R8586,87	ERJ2GEJ560X	M 56 OHM, J,0.063W	2	
	R8589	ERJ2GEJ473	M 47KOHM, J,0.063W	1	
	R8593	ERJ2GEJ473	M 47KOHM, J,0.063W	1	
	R8597-01	ERJ2GEJ473	M 47KOHM, J,0.063W	5	
	R8602	ERJ2GEJ222	M 2.2KOHM, J,0.063W	1	
	R8604	ERJ2GEJ103	M 10KOHM, J,0.063W	1	
	R8661	ERJ2GEJ103	M 10KOHM, J,0.063W	1	
	R8663	ERJ2GEJ103	M 10KOHM, J,0.063W	1	
	R8721-23	ERJ2GEJ680	M 68 OHM, J,0.063W	3	
	R8725,26	ERJ2GEJ473	M 47KOHM, J,0.063W	2	
	R8730	ERJ2GEJ220	M 22 OHM, J,0.063W	1	
	R8732,33	ERJ2GEJ680	M 68 OHM, J,0.063W	2	
	R8734	ERJ2RKD330	M 33 OHM, J, 2W	1	
	R8735-37	ERJ2GEJ331	M 330 OHM, J,0.063W	3	
	R8765	D1BB75R0A055	M 75 OHM, 1/10W	1	
	R8767	D1BB75R0A055	M 75 OHM, 1/10W	1	
	R8769	ERJ2RKD330	M 33 OHM, J, 2W	1	
	R8770	ERJ2GEJ103	M 10KOHM, J,0.063W	1	
	R8772,73	ERJ2GEJ103	M 10KOHM, J,0.063W	2	
	R8844	ERJ2GEJ473	M 47KOHM, J,0.063W	1	
	R8866	D1BB91R0A055	M 91 OHM, 1/10W	1	
	RM2500	B3RAD0000127	REMOCON RECEIVE	1	
△	PCB	NOAB4GJ00005	POWER UNIT	1	PAVCA
△	PCB	TXN/A10PUGS	CIRCUIT BOARD A	1	(RTL) PAVCA
△	PCB	TNPA4834ABS	CIRCUIT BOARD V	1	(RTL) PAVCA
△	TU8300	ENG36E37KF	TUNER	1	PAVCA
	V10	K1KA07B00135	7P CONNECTOR	1	PAVCA
	X4000	H0J196500022	CRYSTAL	1	PAVCA
	X8001	H0J270500061	CRYSTAL	1	
	X8300	H0J250500079	CRYSTAL	1	PAVCA
	ZA5400-03	TESA169	SHIELD CLIP	4	
	ZA5409-11	TESA169	SHIELD CLIP	3	