

Service Manual

Hybrid IP-PBX

KX-TDA200BX

(for Asia, Middle Near East, South America and Africa)

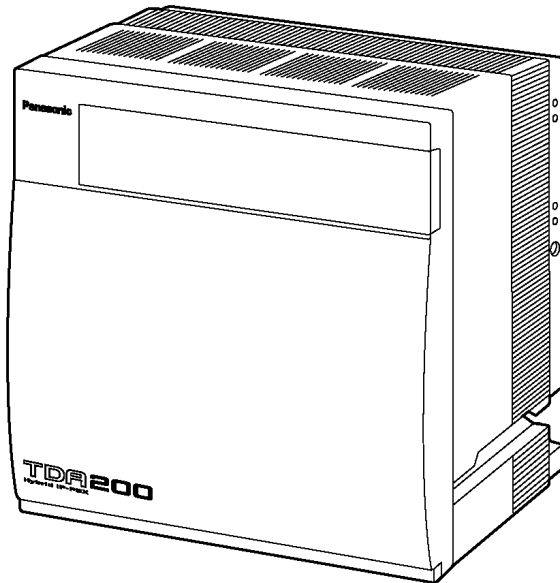

WARNING

This service information is designed for experienced repair technicians only and is not designed for use by the general public. It does not contain warnings or cautions to advise non-technical individuals of potential dangers in attempting to service a product. Products powered by electricity should be serviced or repaired only by experienced professional technicians. Any attempt to service or repair the product or products dealt with in this service information by anyone else could result in serious injury or death.

When you note the serial number, write down all of the 11 digits. The serial number may be found on the unit.

IMPORTANT INFORMATION ABOUT LEAD FREE, (PbF), SOLDERING

If lead free solder was used in the manufacture of this product the printed circuit boards will be marked PbF. Standard leaded, (Pb), solder can be used as usual on boards without the PbF mark.

When this mark does appear please read and follow the special instructions described in this manual on the use of PbF and how it might be permissible to use Pb solder during service and repair work.

Panasonic

© 2003 Panasonic Communications Co., Ltd. All rights reserved. Unauthorized copying and distribution is a violation of law.

CONTENTS

	Page		Page
1 ABOUT LEAD FREE SOLDER (PbF: Pb free)	3	11.1. INTRODUCTION	31
1.1. SUGGESTED PbF SOLDER	3	11.2. TYPICAL EXAMPLE	32
1.2. HOW TO RECOGNIZE THAT Pb FREE SOLDER IS USED	4	11.3. MPR CARD	33
2 FOR SERVICE TECHNICIANS	4	11.4. ERROR LOG	50
3 CAUTION	5	12 DIAGNOSIS	55
3.1. NOTE	5	12.1. DIAGNOSIS FEATURES	55
3.2. SAFETY PRECAUTIONS	5	12.2. DIAGNOSIS TEST	59
3.3. INSULATION RESISTANCE TEST	5	13 IC DATA	64
3.4. BATTERY CAUTION	5	13.1.	64
3.5. CAUTION	5	14 TERMINAL GUIDE OF ICS, TRANSISTORS AND DIODES	68
4 SPECIFICATIONS	6	15 HOW TO REPLACE A FLAT PACKAGE IC	69
4.1. GENERAL DESCRIPTION	6	15.1. PREPARATION	69
4.2. CHARACTERISTICS	6	15.2. PROCEDURE	69
4.3. SYSTEM CAPACITY	7	15.3. REMOVING SOLDER FROM BETWEEN PINS	69
5 SYSTEM OVERVIEW	8	16 CABINET AND ELECTRICAL PARTS LOCATION	70
5.1. SYSTEM CONFIGURATIONS	8	16.1. EXTENSION BOARDS FOR SERVICING	71
5.2. SYSTEM COMPONENTS	9	17 ACCESSORIES AND PACKING MATERIALS	72
5.3. SYSTEM CONNECTION DIAGRAM	10	18 REPLACEMENT PARTS LIST	73
6 NAME AND LOCATIONS	12	18.1. CABINET AND ELECTRICAL PARTS	73
7 DISASSEMBLY INSTRUCTIONS	13	18.2. ACCESSORIES AND PACKING MATERIALS	73
7.1. DISASSEMBLY INSTRUCTION (MPR CARD)	13	18.3. MPR CARD PARTS	74
7.2. DISASSEMBLY INSTRUCTION (BACK BOARD)	14	18.4. BACK/LED BOARD PARTS	79
8 OUTLINE	16	18.5. FIXTURES AND TOOLS	80
8.1. GENERAL DESCRIPTION	16	19 FOR THE SCHEMATIC DIAGRAM	81
8.2. SYSTEM CONTROL	17	20 SCHEMATIC DIAGRAM	82
8.3. BACK BOARD SIGNAL CONNECTION DIAGRAM	20	20.1. MPR CARD	82
9 MPR CARD CIRCUIT OPERATION	23	20.2. BACK/LED BOARD	87
9.1. MPR CARD	23	20.3. WAVEFORM	90
10 BACK BOARD CIRCUIT OPERATION	30	21 PRINTED CIRCUIT BOARD	92
11 TROUBLESHOOTING GUIDE	31	21.1. MPR CARD	92
		21.2. BACK/LED BOARD	94

1 ABOUT LEAD FREE SOLDER (PbF: Pb free)

Note:

In the information below, Pb, the symbol for lead in the periodic table of elements, will refer to standard solder or solder that contains lead.

We will use PbF when discussing the lead free solder used in our manufacturing process which is made from Tin, (Sn), Silver, (Ag), and Copper, (Cu).

This model, and others like it, manufactured using lead free solder will have PbF stamped on the PCB. For service and repair work we suggest using the same type of solder although, with some precautions, standard Pb solder can also be used.

Caution

- PbF solder has a melting point that is 50° ~ 70° F, (30° ~ 40°C) higher than Pb solder. Please use a soldering iron with temperature control and adjust it to 700° ± 20° F, (370° ± 10°C). In case of using high temperature soldering iron, please be careful not to heat too long.
- PbF solder will tend to splash if it is heated much higher than its melting point, approximately 1100°F, (600°C).
- If you must use Pb solder on a PCB manufactured using PbF solder, remove as much of the original PbF solder as possible and be sure that any remaining is melted prior to applying the Pb solder.
- When applying PbF solder to double layered boards, please check the component side for excess which may flow onto the opposite side (See figure, below).

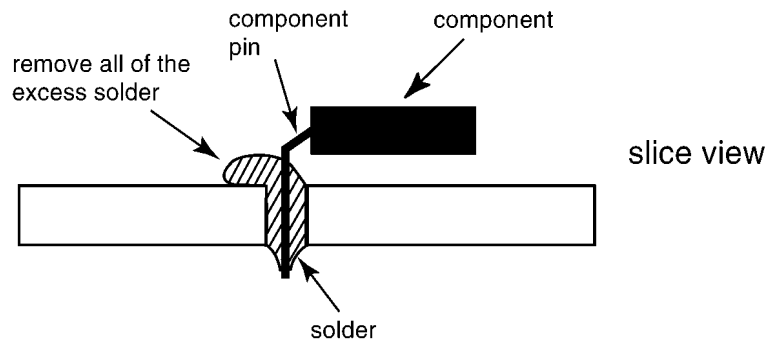

1.1. SUGGESTED PbF SOLDER

There are several types of PbF solder available commercially. While this product is manufactured using Tin, Silver, and Copper, (Sn+Ag+Cu), you can also use Tin and Copper, (Sn+Cu), or Tin, Zinc, and Bismuth, (Sn+Zn+Bi). Please check the manufacturer's specific instructions for the melting points of their products and any precautions for using their product with other materials.

The following lead free (PbF) solder wire sizes are recommended for service of this product: 0.3mm, 0.6mm and 1.0mm.

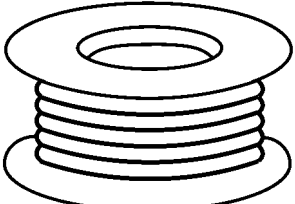
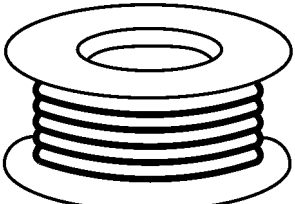
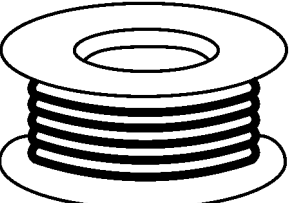
0.3mm X 100g	0.6mm X 100g	1.0mm X 100g
		

3 CAUTION

3.1. NOTE

When you note the serial number, write down all of the 11 digits.

The serial number may be found on the label affixed to the bottom of the unit.

3.2. SAFETY PRECAUTIONS

1. Before servicing, unplug the power cord to prevent an electric shock.
2. When replacing parts, use only the manufacturer's recommended components for safety.
3. Check the condition of the power cord. Replace if wear or damage is evident.
4. After servicing, be sure to restore the lead dress, insulation barriers, insulation papers, shields, etc.
5. Before returning the serviced equipment to the customer, be sure to perform the following insulation resistance test to prevent the customer from being exposed to shock hazards.

3.3. INSULATION RESISTANCE TEST

1. Unplug the power cord and short the two prongs of the plug with a jumper wire.
2. Turn on the power switch.
3. Measure the resistance value with ohmmeter between the jumpered AC plug and each exposed metal cabinet part, such as screw threads, control shafts, handle brackets, etc.

Note:

Some exposed parts may be isolated from the chassis by design. These will read infinity.

4. If the measurement is outside the specified limits, there is a possibility of shock hazard. The equipment should be repaired and rechecked before it is returned to the customer.

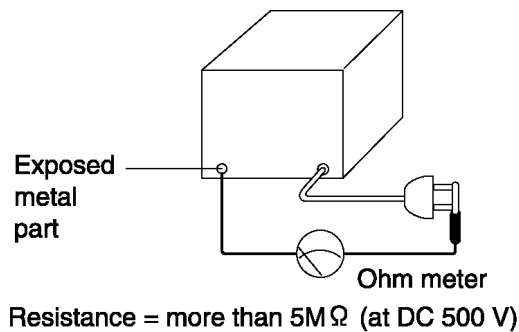

3.4. BATTERY CAUTION

1. Danger of explosion if battery is incorrectly replaced. Replace only with the same or equivalent type recommended by the manufacturer. Dispose of used batteries according to the manufacturer's Instructions.
2. The lithium battery is a critical component (type No.CR23541). Please observe for the proper polarity and the exact location when replacing it and soldering the replacement lithium battery in.

3.5. CAUTION

The power socket wall outlet should be located near this equipment and be easily accessible.

4 SPECIFICATIONS

4.1. GENERAL DESCRIPTION

Control Bus		Original bus (16 bit, 8 MHz, 10 megabytes per second)	
Communication Bus		H.100 bus conformity (1024 time slot)	
Switching		Non Blocking Distributed Time Switch	
Power Input	PSU-M (KX-TDA0104)	100 V AC to 130 V AC/200 V AC to 240 V AC, 2.5 A/1.4 A, 50 Hz/60 Hz	
	PSU-L (KX-TDA0103)	100 V AC to 130 V AC/200 V AC to 240 V AC, 5.1 A/2.55 A, 50 Hz/60 Hz	
External Battery		+36 V DC (+12 V DC x 3, battery capacity of 28 Ah or below recommended for 1 external battery)	
Maximum Power Failure Tolerance		300 ms (without using backup battery)	
Memory Backup Duration		7 years	
Dialling	Trunk	Dial Pulse (DP) 10 pps, 20 pps Tone (DTMF) Dialling	
	Extension	Dial Pulse (DP) 10 pps, 20 pps Tone (DTMF) Dialling	
Mode Conversion		DP-DTMF, DTMF-DP	
Ring Frequency		20 Hz/25 Hz (selectable)	
Trunk Loop Limit		1600 Ω maximum	
Operating Environment	Temperature	0 °C to 40 °C	
	Humidity	10% to 90% (non condensing)	
Conference Call Trunk		From 10 x 3-party conference call to 4 x 8-party conference call	
Music on Hold (MOH)		2 ports (Level Control: -11 dB to +11 dB in 1 dB steps) MOH1: External Music Source port MOH2: Selectable Internal/External Music Source port	
Paging	Internal	Level Control: -6 dB to +3 dB in 3 dB steps	
	External	2 ports (Volume Control: -15 dB to +15 dB in 1 dB steps)	
Serial Interface Port	RS-232C	1 (max 115.2 kbps)	
	USB	1	
Extension Connection Cable		SLT	1 pair wire (T, R)
		DPT	1-pair wire (D1, D2) or 2-pair wire (T, R, D1, D2)
		APT	2-pair wire (T, R, D1, D2)
		DSS Consoles and Add-on Key Module	1-pair wire (D1, D2)
Dimension	KX-TDA200	430 mm (W) x 415 mm (H) x 270 mm (D) (17 1/5 in x 16 3/5 in x 10 4/5 in)	
Weight (when fully mounted)	KX-TDA200	Under 16 kg (35.2 lb)	

4.2. CHARACTERISTICS

Terminal Equipment Loop Limit	<ul style="list-style-type: none"> • PT: KX-T76xx series and KX-T7560/KX-T7565: 90 Ω; all other DPTs/APTs: 40 Ω • SLT: 600 Ω including set • Doorphone: 20 Ω • CS: 130 Ω
Minimum Leakage Resistance	15000 Ω maximum
Maximum Number of Extension Instruments per Line	1 for PT or SLT 2 by Parallel or eXtra Device Port connection of a PT and an SLT
Ring Voltage	75 Vrms at 20 Hz/25 Hz depending on the Ringing Load
Trunk Loop Limit	1600 Ω maximum
Hookswitch Flash/Recall Timing Range	24 ms to 2032 ms
BRI Cards Internal ISDN Mode	Supply Voltage: 40 V Power Supply: 4.5 W per 1 line, 10 W per 4 lines (BRI4) 4.5 W per 1 line, 20 W per 8 lines (BRI8) Power Supply Method: Phantom Power Supply
Door Opener Current Limit	24 V DC/30 V AC, 1 A maximum
Paging Terminal Impedance	600 Ω
MOH (Music on Hold) Terminal Impedance	10000 Ω

4.3. SYSTEM CAPACITY

4.3.1. Maximum Trunk and Extension Cards

The following number of trunk and extension cards can be installed in the main unit (Hybrid IP-PBX) for expansion.

Card Type	KX-TDA200
Trunk Card *1	8
Extension Card	8
Total	10

*1 One T1, E1, PRI30 and PRI23 card counts as 2 cards.

Note:

- For each card, a maximum number that can be installed in the main unit (Hybrid IP-PBX) is listed in "Installation Manual".
- Any card that exceeds the capacity of the main unit (Hybrid IP-PBX) will be ignored.
- When the main unit (Hybrid IP-PBX) starts up with an invalid configuration mode, some cards will be ignored.

4.3.2. Maximum Terminal Equipment

The following number of terminal equipment can be supported by the main unit (Hybrid IP-PBX).

Terminal Equipment Type	KX-TDA200
Telephone *1	128
CS	32
PS	128
Voice Mail	2
Doorphone	16
Door Opener	16

*1 When only T76xx series and T7560, T7565 DPTs and SLTs are connected. If other DPTs or APTs are connected, the maximum number will decrease as each of these units is counted as 4 sets of SLTs or DPTs (T76xx series and T7560, T7565).

4.3.3. Power Supply Unit Selection

Main unit (Hybrid IP-PBX) needs an optional power supply unit (PSU) suitable for its configuration. Calculate the amount of "load figures" from the type and number of equipment to be connected, and determine the type of PSU that will be required.

Load Figure Calculation

Equipment Type		Load Figure
PT	DPT (T76xx series and T7560, T7565)	1
	Other DPT/APT/DSS Console	4
Extension Card *1	DHLC8	8
	SLC8	8
	SLC16	16
	MSLC16	16
CS		4
ISDN Extension		2
Voice Mail		1

*1 Only the extension cards that can support SLTs count for the load figures.

PSU Capability

Each PSU supports a different amount of load figures.

PSU Type	Maximum Load Figures
PSU-M *2	128
PSU-L	512

*2 Available for the KX-TDA100 and KX-TDA200.

5 SYSTEM OVERVIEW

5.1. SYSTEM CONFIGURATIONS

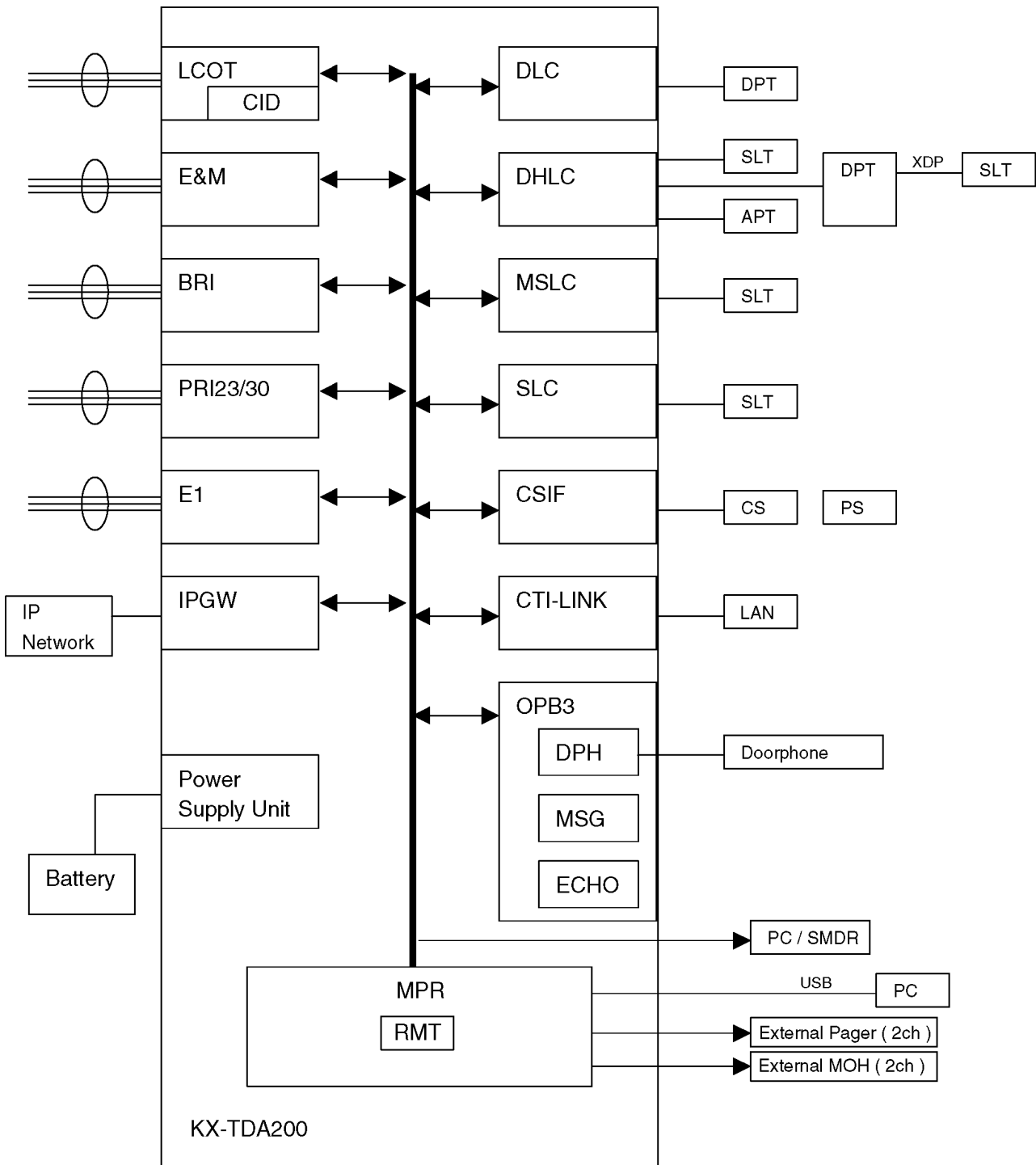

5.2. SYSTEM COMPONENTS

	Model	Card Name	Description
Shelf	KX-TDA200BX		Basic Shelf
Main Central Processing Card		MPR	Main Processing Card
MPR Option Card	KX-TDA0196XJ	RMT	Remote Card
CO Line Cards	KX-TDA0180X KX-TDA0181X KX-TDA0184XJ KX-TDA0188XJ KX-TDA0193XJ KX-TDA0284XJ KX-TDA0288XJ KX-TDA0290CJ KX-TDA0290X KX-TDA0480X	LCOT8 LCOT16 E&M8 E1 CID8 BRI4 BRI8 PRI30 PRI23 IP-GW4	8-Port Analogue Trunk Card 16-Port Analogue Trunk Card 8-Port E & M Trunk Card E-1 Trunk Card 8-Port Caller ID Card 4-Port BRI Card 8-Port BRI Card PRI Card PRI Card 4-Channel VoIP Gateway Card
Extension Cards	KX-TDA0144XJ KX-TDA0170XJ KX-TDA0171XJ KX-TDA0172XJ KX-TDA0173XJ KX-TDA0174XJ KX-TDA0175XJ	CSIF8 DHLC8 DLC8 DLC16 SLC8 SLC16 MSLC16	8 Cell Station Interface Card 8-Port Digital Hybrid Extension Card 8-Port Digital Extension Card 16-Port Digital Extension Card 8-Port Single Line Telephone Extension Card 16-Port Single Line Telephone Extension Card 16-Port Single Line Telephone Extension with Message Lamp Card
Other Cards	KX-TDA0161XJ KX-TDA0166XJ KX-TDA0190XJ KX-TDA0191XJ KX-TDA0410XJ	DHP4 ECHO16 OPB3 MSG4 CTI-LINK	4-Port Doorphone Card 16-Channel Echo Canceller Card Optional 3-Slot Base Card 4-Channel Message Card CTI Link Card
Power Supply Units (PSUs)	KX-TDA0103XJ KX-TDA0104XJ	PSU-L PSU-M	L-Type Power Supply Unit M-Type Power Supply Unit
Cell Stations (CS's)	KX-TDA0142CE		4-Channel Cell Station Unit for DECT Portable Station
Proprietary Equipment	KX-A228XJ KX-A229XJ KX-A258XJ KX-T30865X		S/M-type Back-up Battery Cable L-type Back-up Battery Cable Blank Slot Cover Doorphone

Available Telephones

This main unit (Hybrid IP-PBX) supports all of the Panasonic X-T7xxx and KX-TD7xxx series:

- Digital/Analog proprietary telephones (e.g., KX-T7625, KX-T7630, KX-T7633, KX-T7636)
- Portable stations (e.g., KX-TD7690, KX-TD7680)
- DSS consoles (e.g., KX-T7640)

This main unit (Hybrid IP-PBX) does not support the following telephones:

- KX-T308xx series Proprietary Telephones and DSS consoles
- KX-T616xx series Proprietary Telephones and DSS consoles
- KX-T1232xx series Proprietary Telephones and DSS consoles

For the equipment (e.g., Add-on Key Module, USB Module, Headset) that can be connected to a particular telephone, refer to the telephone's manual.

Abbreviations in this manual

- Proprietary telephone: PT
- Digital proprietary telephone: DPT
- Analog proprietary telephone: APT
- Portable station: PS
- Single line telephone: SLT

Note:

- There are some optional service cards and features that are not available for certain countries/areas. Consult your authorized Panasonic dealer for detailed instructions.
- The power supply capacity of this main unit (Hybrid IP-PBX) may differ from the values described in this manual depending on the model number. Please consult your dealer for detailed information.

5.3. SYSTEM CONNECTION DIAGRAM

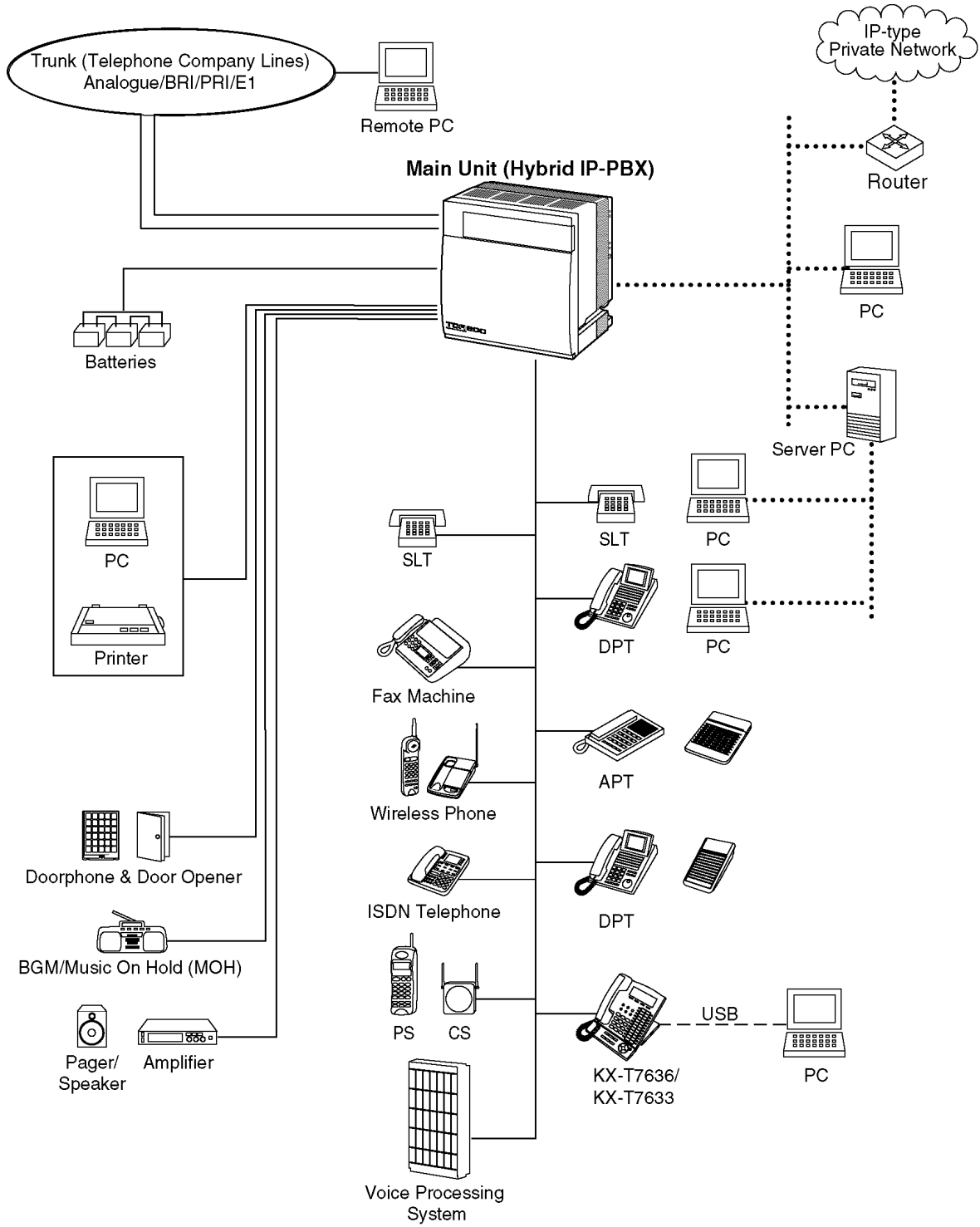

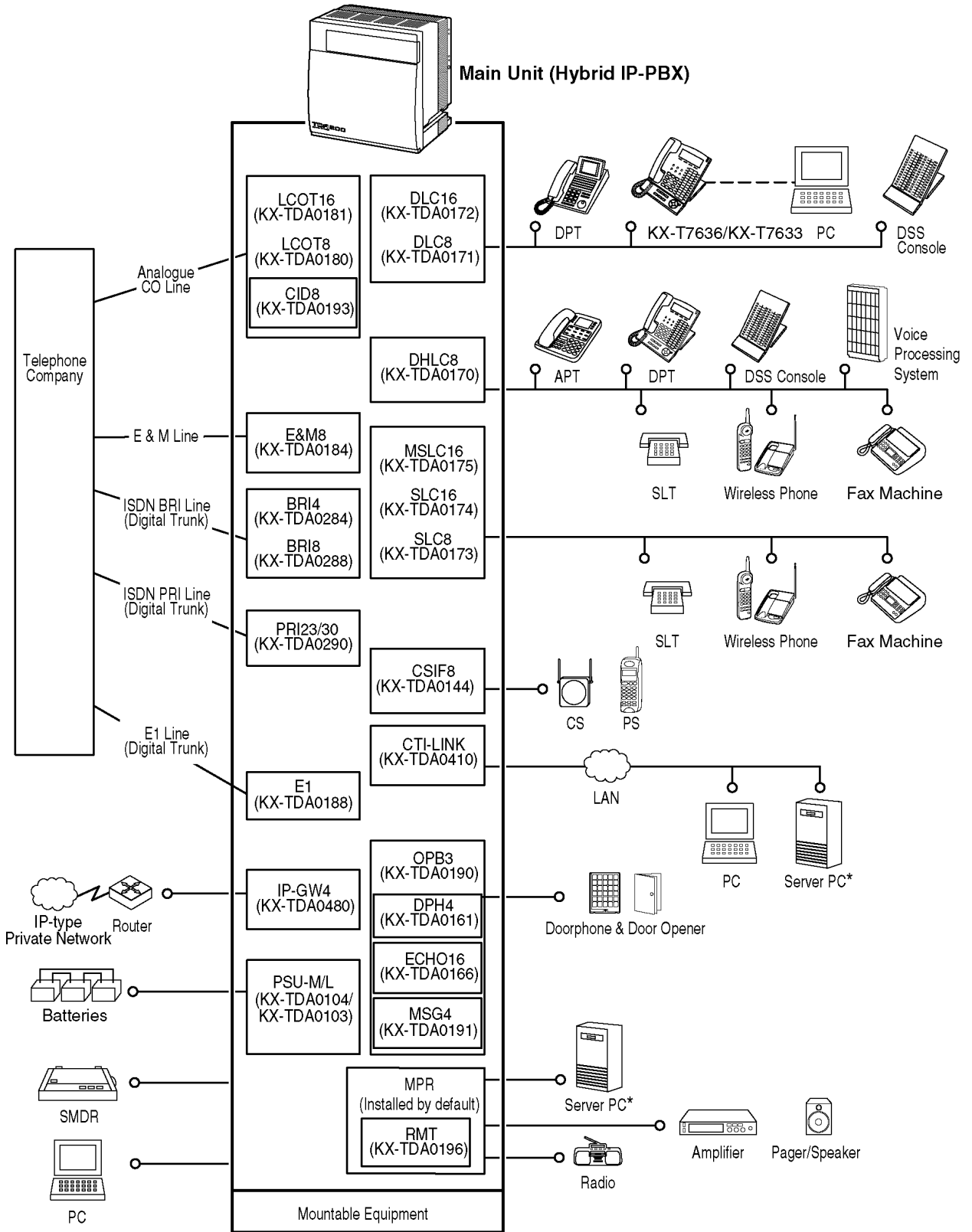

*Only 1 Server PC can be connected to the main unit (Hybrid IP-PBX). Two or more Server PCs cannot be used simultaneously.

6 NAME AND LOCATIONS

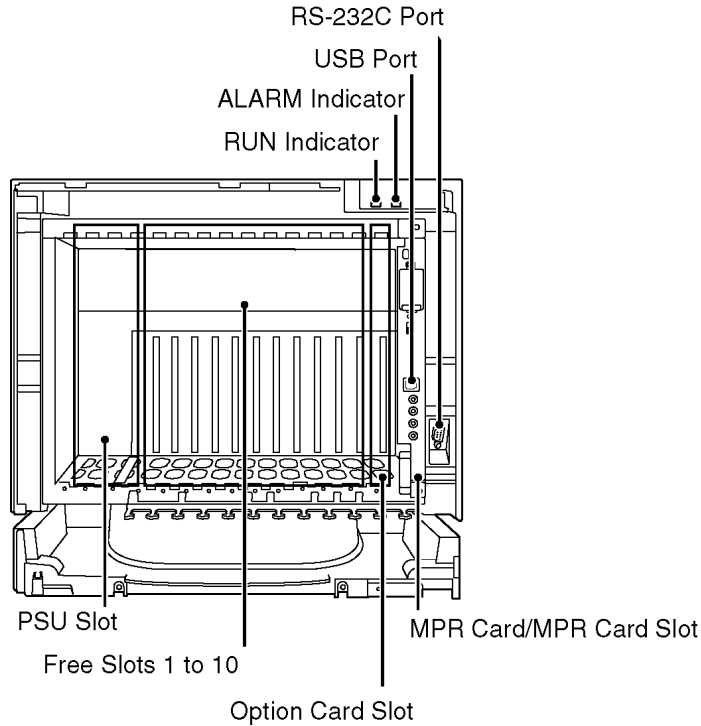

	LED Type	Color	Usage and Status Definition
RUN Indicator	LED1 (Power/RUN)	Green	Display of Power Supply & RUN Status OFF: Power OFF (inc. in normal resetting) ON: Power ON & RUN (On-Line) Flash (60/min.): Power ON & In starting Flash (120/min.): Power ON & In resetting before system clear
ALARM Indicator	LED2 (Alarm)	Red	Display of ALARM OFF: Normal ON: Alarm (CPU stop, Alarm for each card) Flash: Alarm (MPR file error in restarting)

Slot Type	MPR Card	CO Line Cards Extension Cards	OPB3 Card CTL-LINK Card
Free Slots 1 to 10	No	Yes	Yes
Option Card Slot	No	No	Yes
MPR Card Slot	Yes	No	No

7 DISASSEMBLY INSTRUCTIONS

7.1. DISASSEMBLY INSTRUCTION (MPR CARD)

1. Remove the Lib by sliding it in the direction of arrow 1.
2. This will be removed if the user attached a Pad Lock as shown in a Fig.1.
3. Loosen the Screw.
4. Front Cover is removed in the direction of arrow 2.

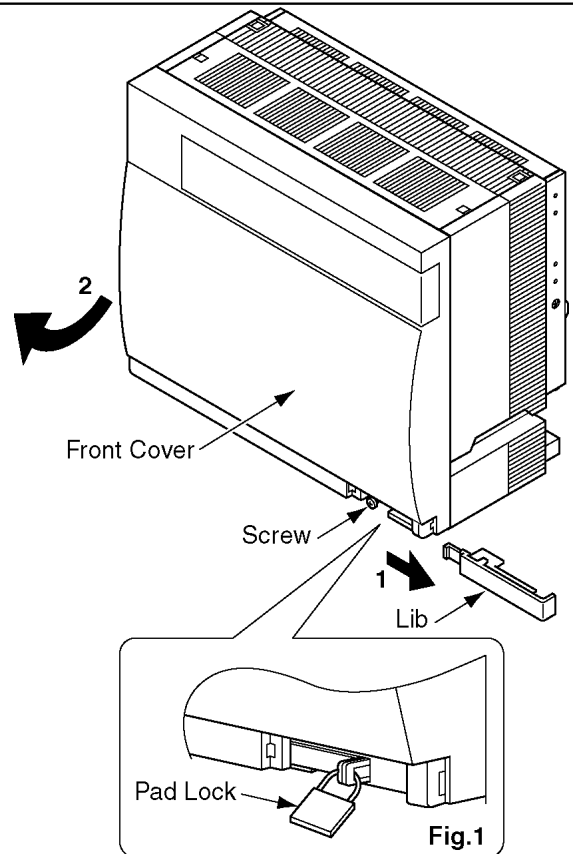

5. Loosen the two Screws.
6. Remove the MPR Card.

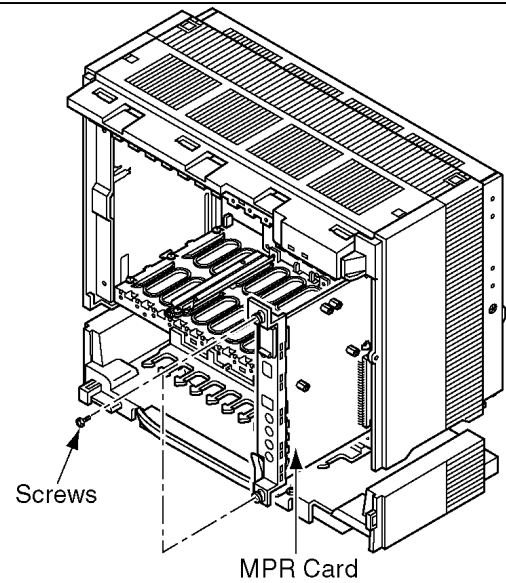

7.2. DISASSEMBLY INSTRUCTION (BACK BOARD)

1. Remove four Screws (A).
2. Remove the Left Side Cover and the Right Side Cover.

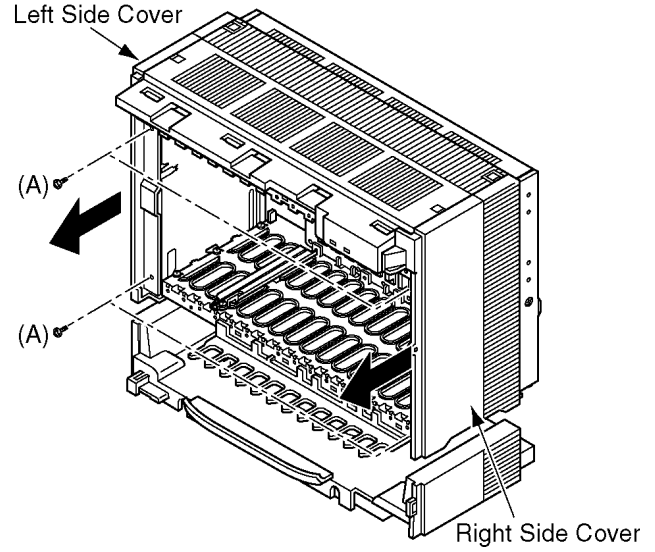

3. Remove the Hook. Remove the Top Cover.

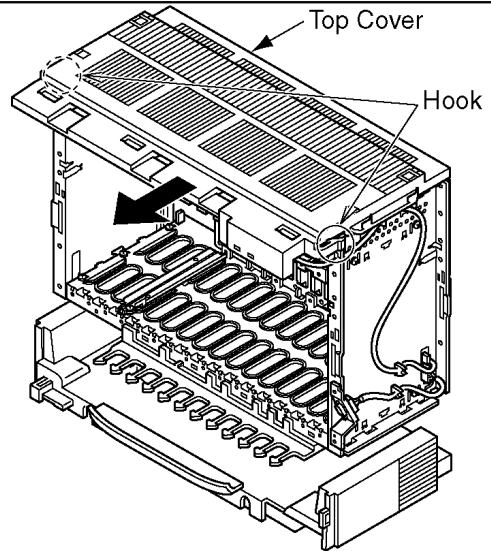

4. Remove nine Screws (B).
5. Remove the Back Cover.

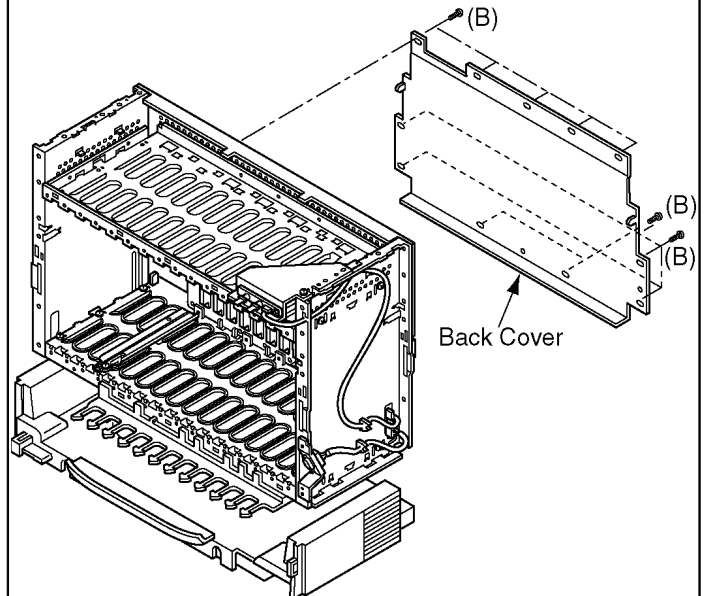

6. Remove the RS-232C Connector and LED Connector from Back Board 1.
7. Remove eight Screws (C).
8. Remove Back Board 1.

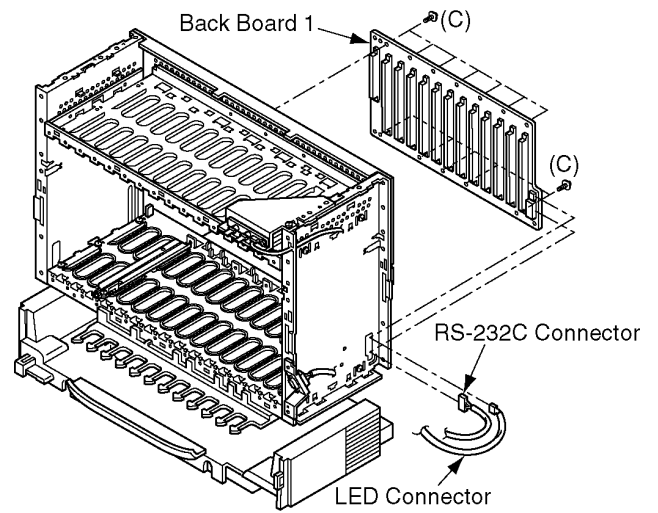

9. Remove the LED Connector from Back Board 2.
10. Remove the Screw (C).
11. Remove Back Board 2.

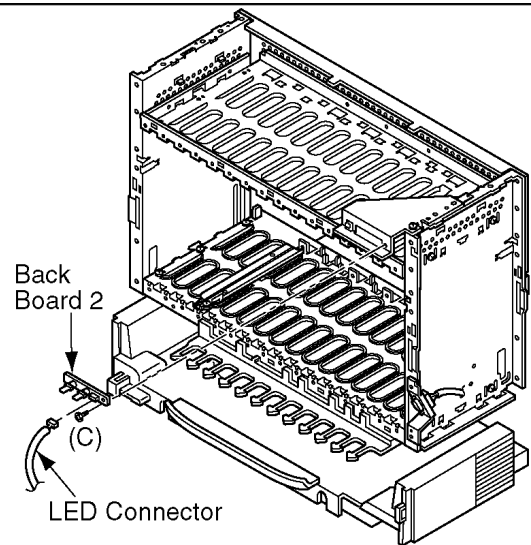

8 OUTLINE

8.1. GENERAL DESCRIPTION

The control system of the main unit is composed of the main central processing card (MPR card) controlling the entire system and exchanging voice data, the circuit control section (LPR/LC) controlling various telephone lines and the power supply section (POWER).

MPR card, LPR/LC and POWER are connected each other through the System BUS (ADDRESS BUS, DATA BUS and CONTROL BUS). MPR card and LPR/LC are under I/O control (I/O Read/Write) by MPR card.

MPR card controls LPR which have a microprocessor by the Inter-Microprocessor Communication System supported by ASIC. Those are, MPR card and LPR exchange controlling messages through bi-directional buffer and CPU controls LPR so that it can manage multiple telephone lines. Since LC does not have a microprocessor, it is completely controlled through ASIC from MPR card.

I/O address for LPR access is fixed for each free slot. CPU discriminates the sort of LPR through the inter-processor communication system.

POWER detects the voltage drop of the AC input and the DC output and transfers it to MPR card.

8.1.1. MPR Card

This card is the main control section of main unit. It controls all the cards mounted on the free slots, and communication of RS-232C ports.

There are two LED (BATT ALARM, SD ACCESS), one SD card slot, one push switch, one slide switch, one USB port, two MOH jacks, and two EPG jacks in the front of MPR card. BATT ALARM LED light red if the output of the lithium battery in MPR card is set to about 2.8V or less. During access to SD card, it green-blinks or SD ACCESS LED light and blink. Enclosed SD card is used for SD card slot on a main part, putting in. The main program is stored in SD card. It connects with PC and a USB port is used for a maintenance or a system setup. The external sound source for BGM or suspension sound is connected to a MOH jack. A speaker with amplifier is connected to external paging at an EPG jack. Light Emitting Diode (RUN indicator, ALARM indicator) arranged at the main part upper part is directly controlled from MPR card, and shows the state of a system of operation.

This control circuit executes the control signals for the exchange process, and this card is composed of the following

- (A) 32bit CPU (32bit data bus)
- (B) SDRAMs, SRAMs
- (C) Flash memorys
- (D) Lithium Battery for back-up of clock IC and Static RAMs

8.1.2. Back Board

BB (back board) is the mother board of the basic shelf. This board connects each card/unit (POWER, MPR card, and optional service cards) together. This board has one RS-232C connector.

8.1.3. Power Supply Unit

This unit is switching regulator power supply and supplies DC voltages to MPR card, and optional service card (free slot). PSU (power supply unit) has four outputs (40V, 30V, 15VPT, 15V). 15V output is supplied only in MPR card and option card. Other outputs are mainly used as an object for the electric supply to a terminal. Refer to each S/M for the details of PSU.

8.2. SYSTEM CONTROL

8.2.1. System Control Block Diagram

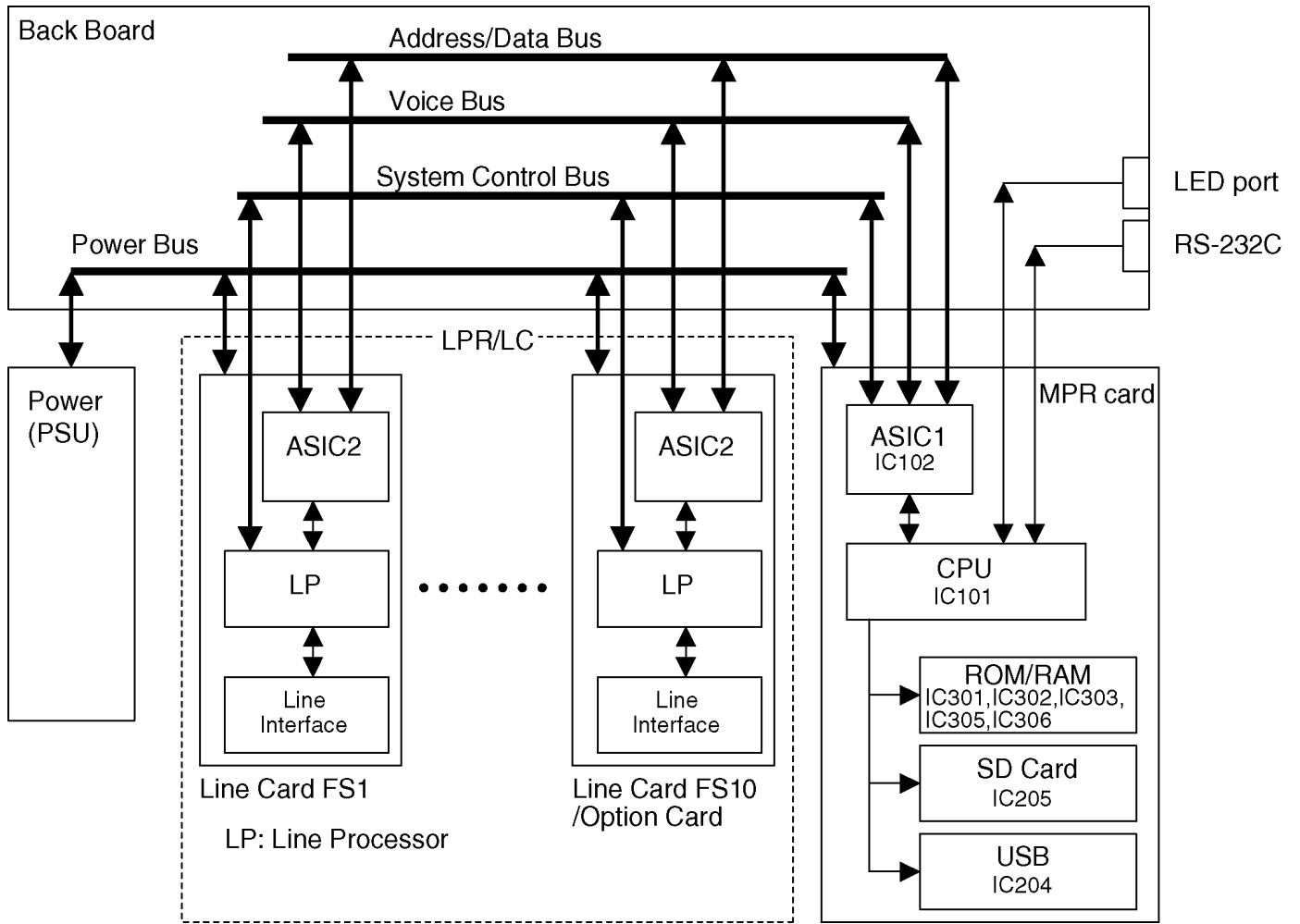

8.2.2. Voice (TDM Highway) Bus Block Diagram

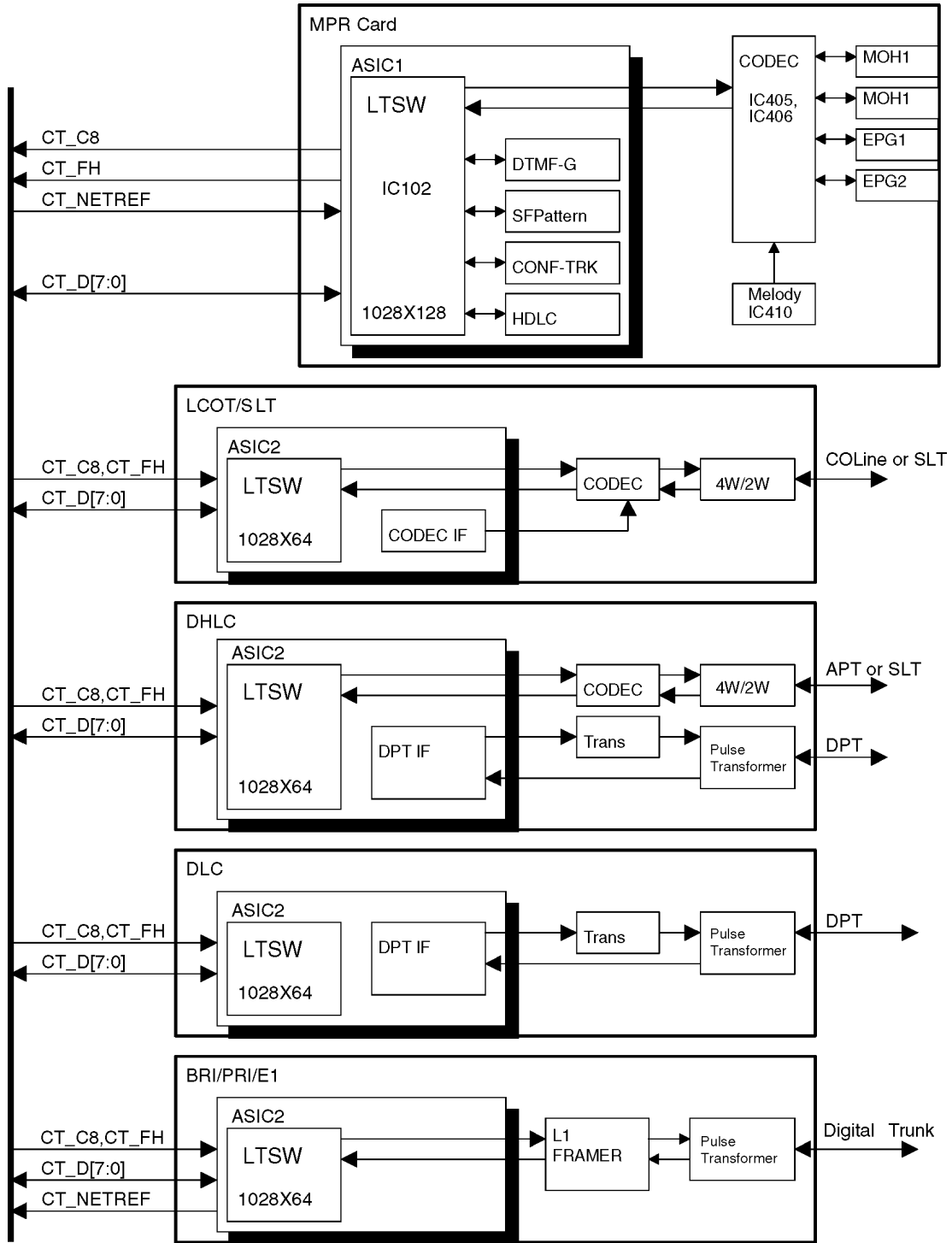

8.2.3. Voice Bus Logical Assignment

	CT_D0	CT_D1	CT_D2	CT_D3	CT_D4	CT_D5	CT_D6	CT_D7
TS0	MPR	MPR						
TS31	LHW	LHW	FS1	FS3	FS5	FS7	FS9	Option
TS63	HDLC							
TS95	THR	CONF	FS2	FS4	FS6	FS8	FS10	
TS127	DTMF							

In the line card, the CT_D line number, which is output in accordance with the inserted slot, and the time slot are assigned by software.

For the detail of output slot for each card (optional service card), refer to the service manual of the card (optional service card).

8.2.4. Back Board Signaling

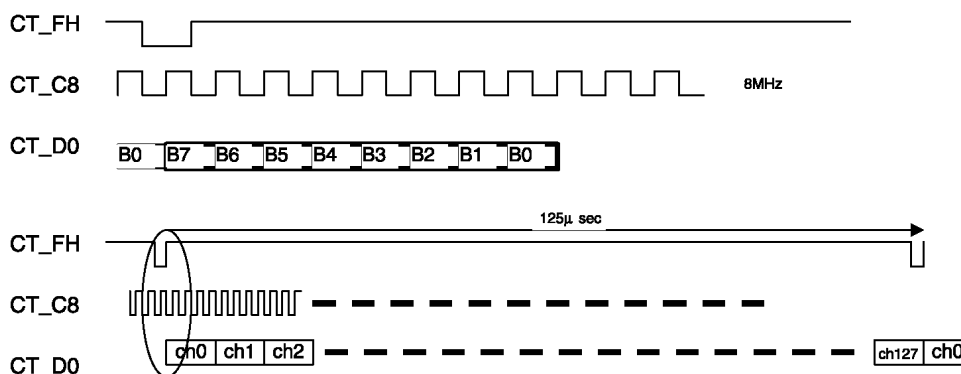

Back board waveform of TDM bus for voice

8.3. BACK BOARD SIGNAL CONNECTION DIAGRAM

8.3.1. CT Bus System Connection Diagram

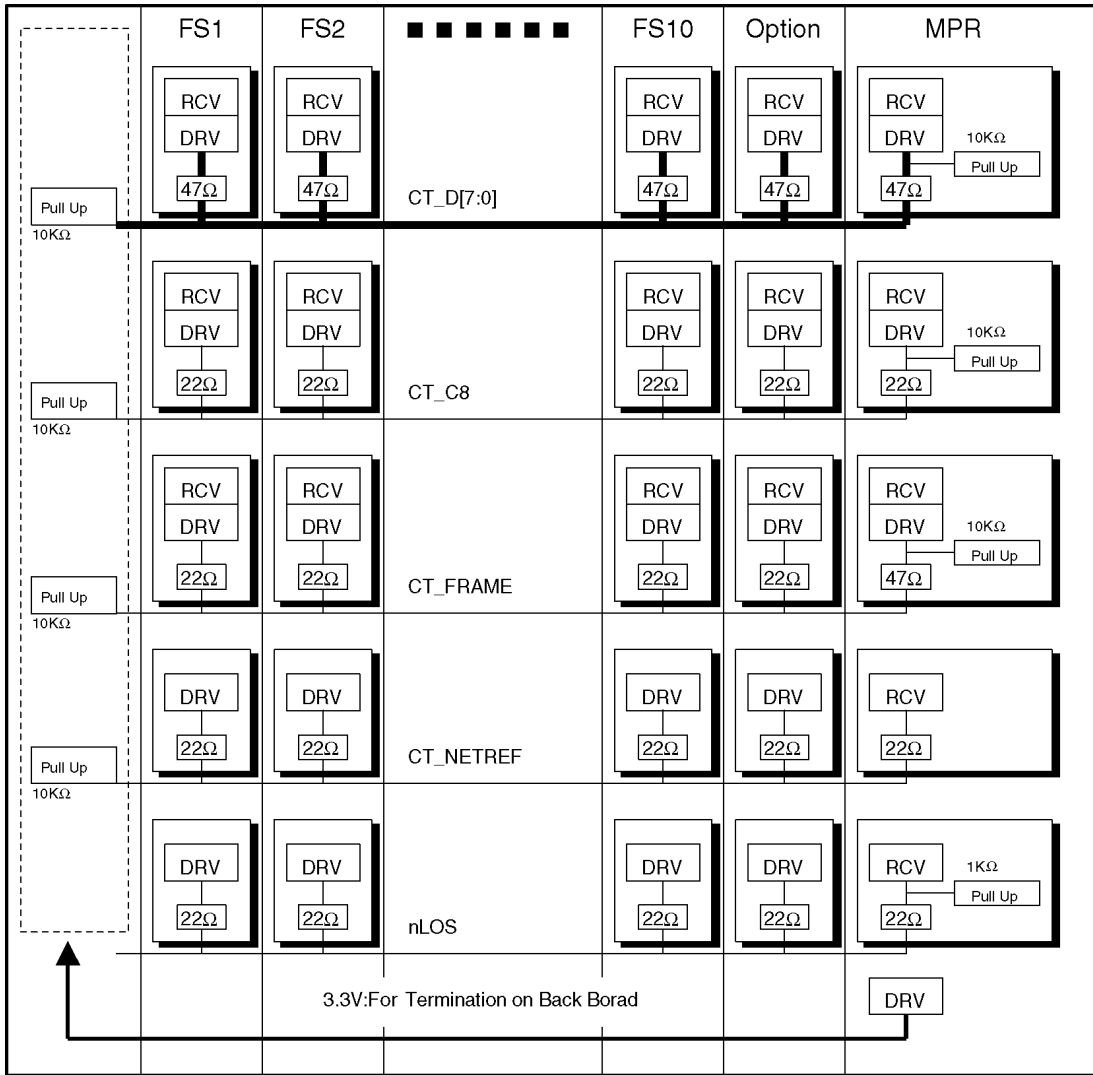

8.3.2. EC Bus System Connection Diagram

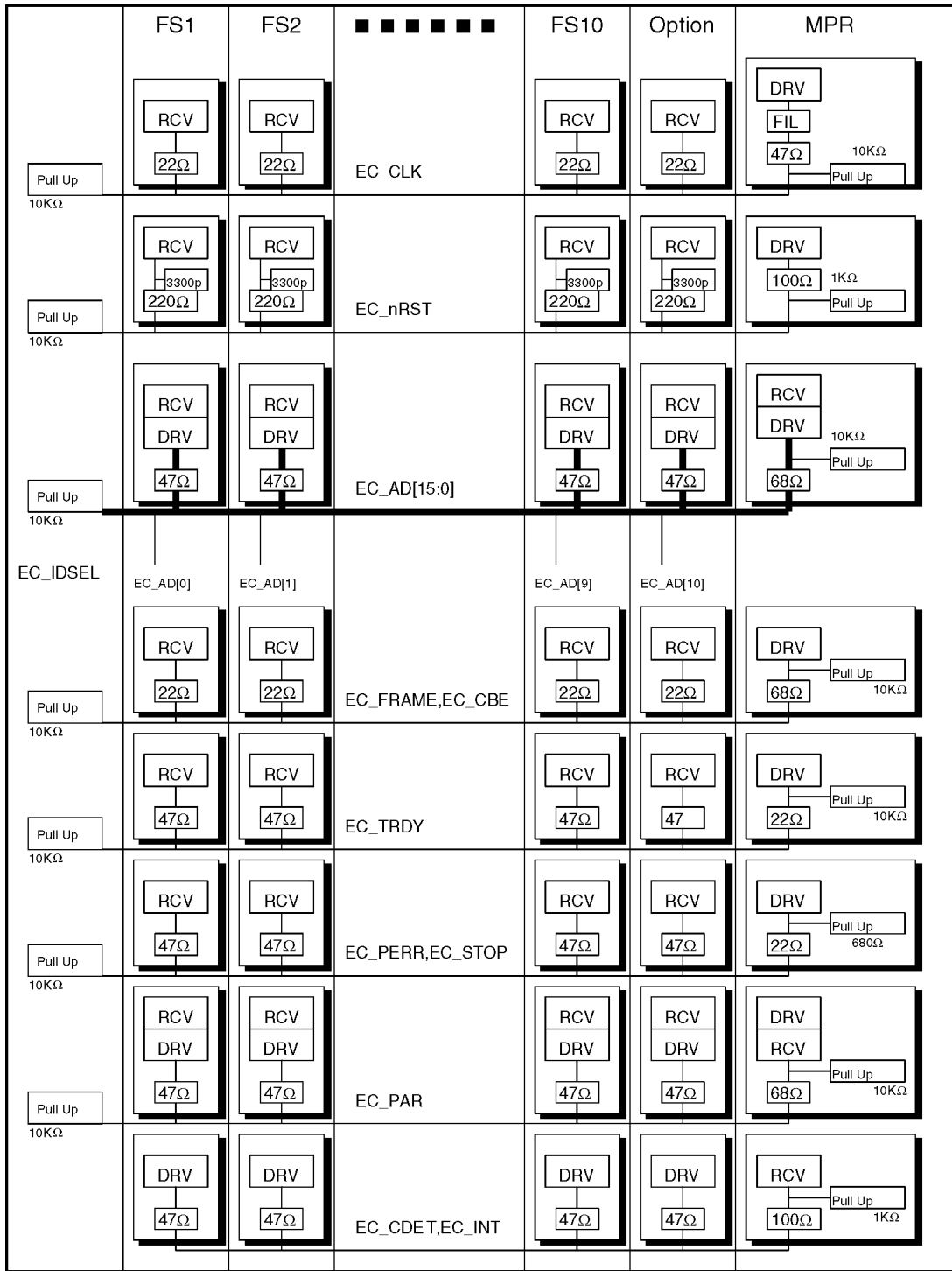

8.3.3. System Control and Analog Signal Connection Diagram

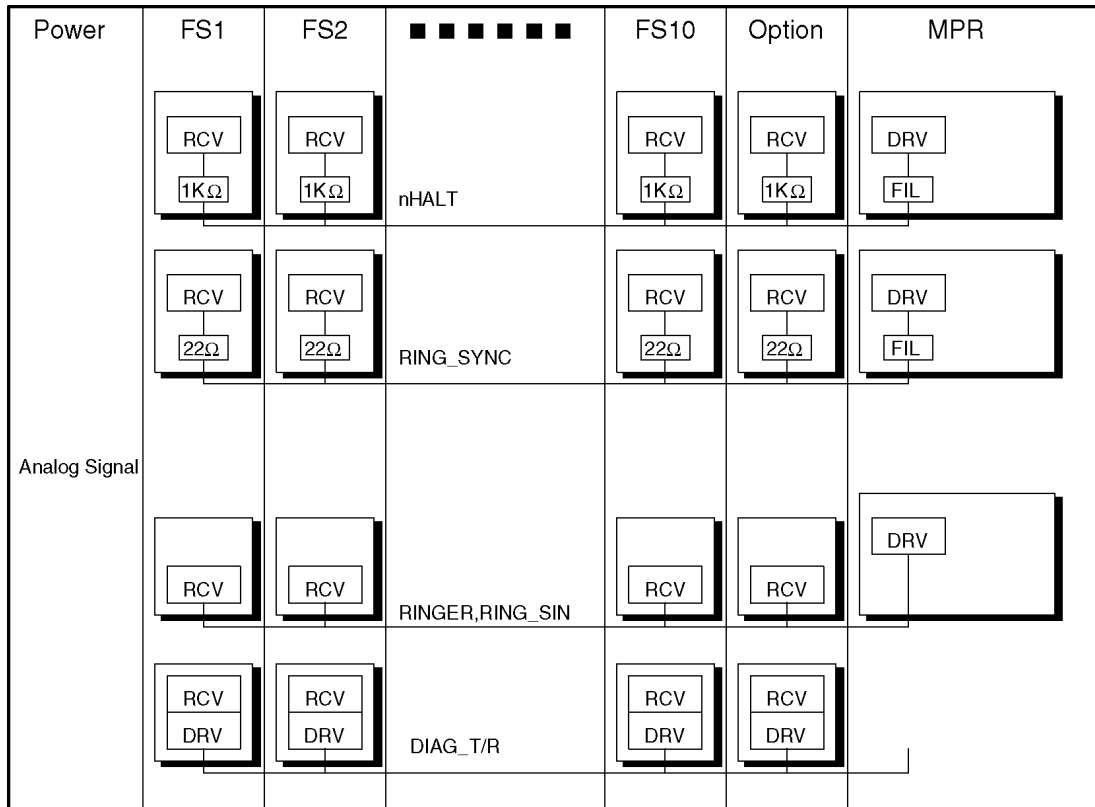

8.3.4. Power Supply System Connection Diagram

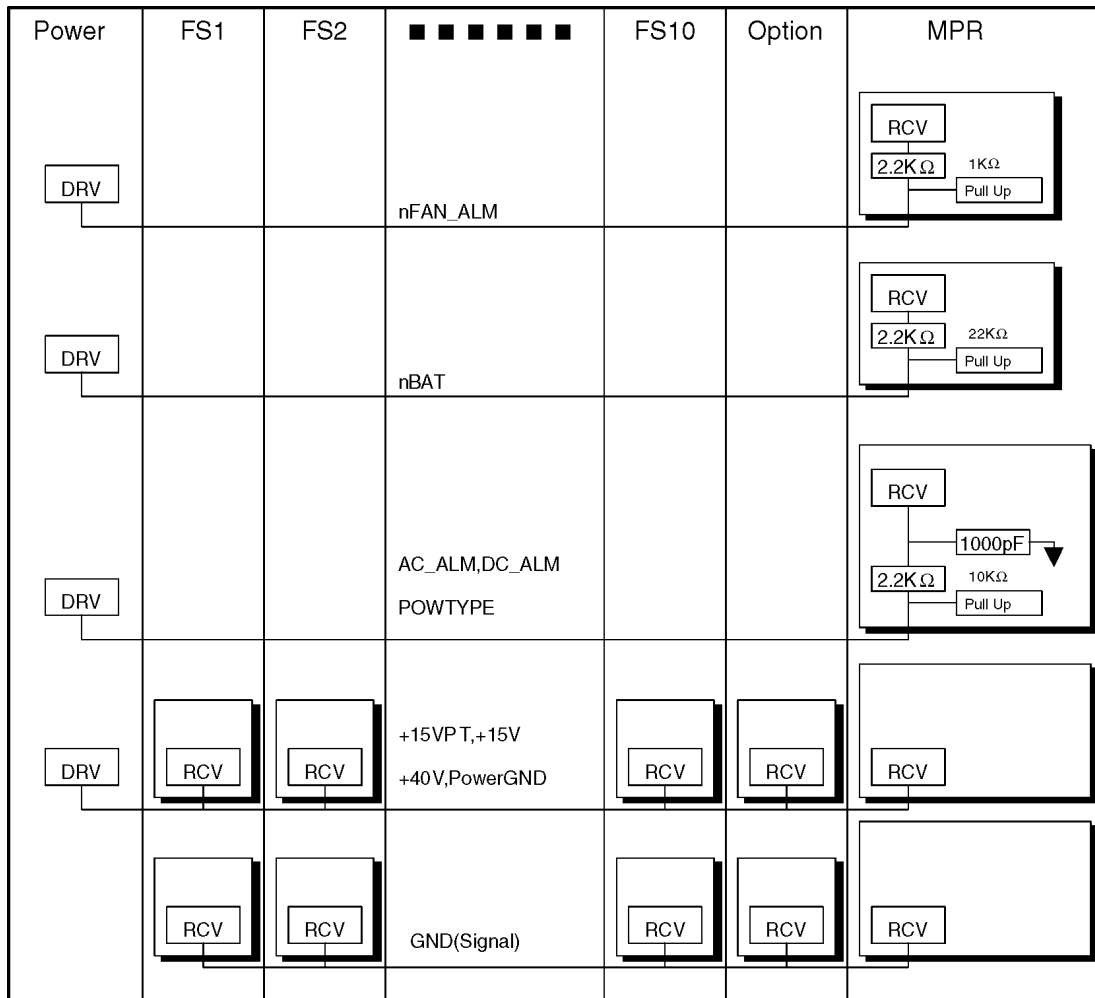

9 MPR CARD CIRCUIT OPERATION

9.1. MPR CARD

9.1.1. Outline

1) Function

- System Control
- Circuit Switching (includes gain adjustment function)
- Conference Call (3 people x 8 ~ 8 people x 3)
- MOH
- PAGING
- Clock

2) Configuration

- Power Supply: DC/DC Converter
- CPU: HITACHI SH7709S (133MHz)
- ASIC: Our own products
- ROM: 4Mbit x 1 (for boot programs)
- SDRAM: 64Mbit x 2 (for work area)
- SRAM: 4Mbit x 2 (for user data backup)
- SD card I/F (for operating programs) x 1
- USB I/F (for PC programming) x 1
- MOH: External sound input x 2
- PAGING: External output x 2
- Expanded memory connector x 1
- Modem card connector x 1

3) Operation Rating

- Power Input : +15V
- Power Output : +15V (for MOH)
 - +3.3V (for I/O)
 - +3.3VBB (back board signal line pull-up)
 - +3.3VB (for SRAM backup)
 - +1.8V (for CPU core)
 - +1.9VB (for clocking backup)
 - ±9.4V (for RS-232C driver/receiver)
 - +5VRMT unused (for remote card)
 - +5V (for RS-232C driver/receiver)

9.1.2. Description of Each Part

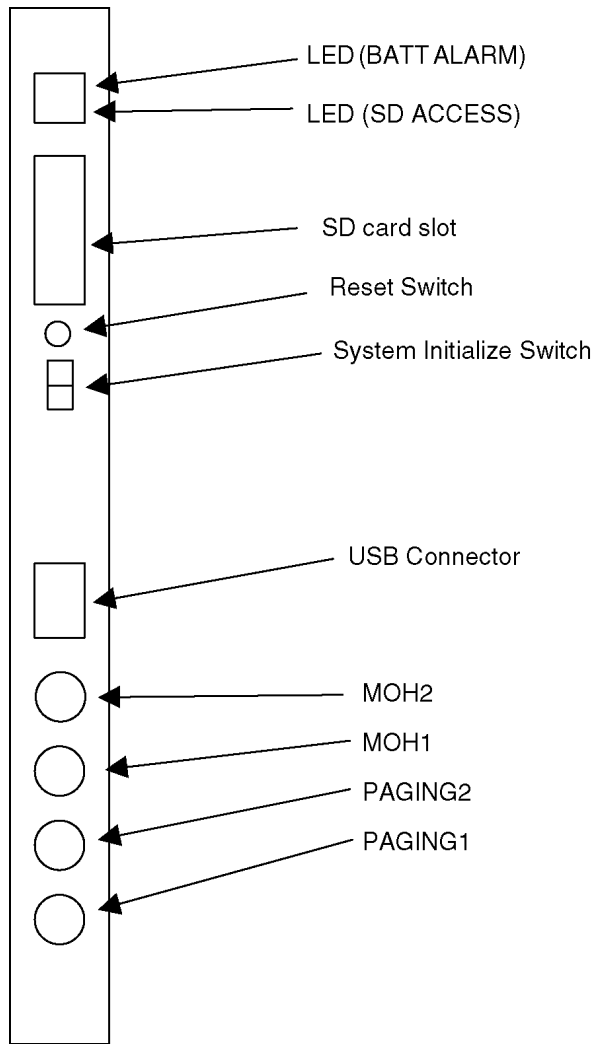

LED (BATALM): Lights when the lithium battery voltage drops below 2.8V.

LED (SD ACCES): Lights on when the SD card is being accessed.

SD card slot: Mounts the system program SD card.

Reset Switch: Press to reset the system.

System Initialize Switch:

On default startup, set the switch to the "SYSTEM INITIALIZE" position before turning the power ON. Return the switch to the "NORMAL" position when the main power switch starts to flash. On normal startup, turn the power ON with this switch in the "NORMAL" position.

USB connector: B-type connector. Used for PC programming.

MOH 1, 2: External music on hold input.

PAGING 1, 2: External PAGING output. Connect to a device with a built-in amplifier.

9.1.3. Block Diagram

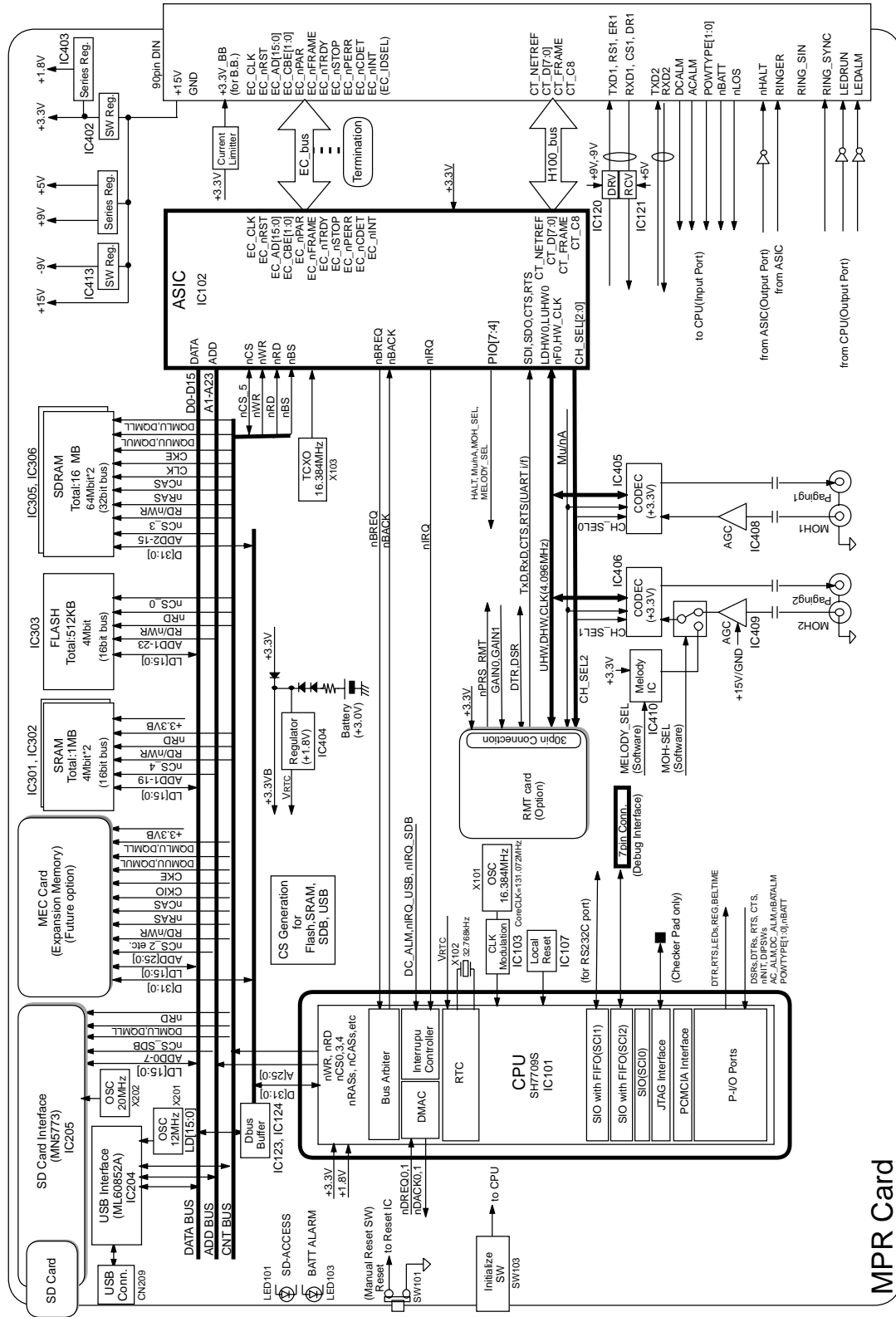

MPR Card

KX-TDA200 MPR CARD BLOCK DIAGRAM

9.1.4. Circuit Description

9.1.4.1. Outline of Block Description

- CPU block

Operates the main unit control. Also operates various controls, generation of select signal, DMA control and serial port control. This contains the built-in clock function.

- ASIC block

Provides the communication between each optional service card, call control (TSW function), conference call, tone generation and gain control function.

- Memory block

This is a work area used for the main unit control program storage, the system boot program storage, or the user configuration data storage.

- USB block

Provides the USB I/F function. Connects to the PC to be used for PC programming or system data load/store.

- SD card block

Provides the SD card I/F function and loads the main unit program and the system data from the SD card containing the main unit control program.

- MOH/PAGING block

Provides the external music on hold input x 2, and the external paging output x 2 port. Also this provides the external music on hold input 1 system and exclusively the internal music on hold output.

- Power block

Consists of DC/DC converter circuit and various regulators.

9.1.4.2. Detail of Block Description

- CPU block

Configuration: IC101 (CPU), IC107 (reset IC), IC103 (spread clock IC), X101 (CPU source clock), X102 (clocking clock) etc.

Function: (IC101)

Generates the select signal in accordance with the memory map and operates read/write of data between each peripheral.

Controls the DMA transfer between USB I/F or built-in serial controller and memory.

Operates input/output control of each I/O signal in accordance with the program.

Contains the built-in clock function (battery backup) with the source clock X102 (32.768 kHz).

(IC107)

Monitoring the power voltage, it generates a reset signal when the voltage drops under the constant value (2.9V_{typ}) or when the reset switch is pressed down.

(IC103)

To reduce unnecessary radiation, it generates the clock with the constant blurring mainly X101 clock output (16.384 MHz).

Description of the Signal on MPR

Signal Name	Functions
+15VIN	+15V DC
+15V	For Circuit +15V DC MOH
+9.4V	For Driver IC +9.4V DC RS-232C
+5V	For Driver IC +5V DC RS-232C
+5VRMT	Reserve
3.3V_BB	+3.3V DC For pull-up of back board signal line
+3.3VB	+3.3V DC Battery backup For SRAM (IC301, IC302) backup
+3.3V	+3.3V DC
1.9VB	+1.9V DC Battery backup For clock function of CPU (IC100)
1.8V	For Core +1.8V DC CPU (IC100)
A[0]-A[25]	Address bus
nAC_ALM	AC alarm signal: Indicates AC voltage cutoff. (L: Alarm condition)
nBACK	Bus Acknowledge: Indicates Bus Acknowledge.
nBATT	Indicates whether external battery is connected or not. L: Connected

Signal Name	Functions
nBAT_ALM	Battery Alarm Signal: Indicates the declined voltage of lithium battery. (L: Alarm condition)
nBREQ	Bus Request: Bus request signal
nBS	Bus Cycle Start: Bus cycle start signal
nCASL	Lower Byte Address Column Address Strobe: CAS signal for SDRAM
nCASU	Upper Byte Address Column Address Strobe: CAS signal for SDRAM
CH_SEL[0]	Synchronous Signal for CODEC (For MOH#1/Page#1)
CH_SEL[1]	Synchronous Signal for CODEC (For MOH#2/Page#2)
CH_SEL[2]	Synchronous Signal for CODEC (For RMT)
CKE	Clock Enable: CKE signal for SDRAM
CKIO	Clock I/O Terminal: For bus clock of SDRAM (IC305, IC306) and ASIC (IC101) CPU (IC100) outputs the clock of four times frequency as Source clock (16.384MHz).
nCS0	Chip Select 0: Chip select signal for flash memory
nCS2	Chip Select 2: Chip select signal for the expanded SDRAM (Future Option, Reserve at present.)
nCS3	Chip Select 3: Chip select signal for SDRAM
nCS4	Chip Select 4: Chip select signal for SRAM
nCS5	Chip Select 5: Chip select signal for ASIC
nCS6	Chip Select 6: Chip select signal for USB I/F and SD card I/F
nCS_FLASH0	Chip Select for Flash memory 0: CS signal for IC303
nCS_FLASH1	Chip Select for Flash memory 1: CS signal for IC304 (reserve)
nCS_SDB0	Chip Select for Sd card I/F
nCS_SDB1	Reserve
nCS_SRAM0	Chip Select for SRAM 0: CS signal for IC301
nCS_SRAM1	Chip Select for SRAM 1: CS signal for IC302
nCS_USB	Chip Select for USB I/F
nCTS2	Clear To Send from RS-232C connector
CTS_RMT	Clear to Send: Flow signal for modem
CT_C8	Clock 8.192MHz clock outputted from PLL master
CT_D[0] -[7]	CT Data Bus: Two-way serial data bus to which the drive from any card is possible in the system.
CT_FRAME	Frame Signal: 8KHz frame signal outputted from the master
CT_NETREF	Backup Synchronous Signal (MAX 2MHz) 8KHz signal output from slave etc.
C_CS[0]	Chip Select For RMT
D[0] -D[31]	Data Bus
nDACK0-1	DMA Acknowledge: For USB I/F
DCD2	Data Carrier Detect
DCLK_RMT	Codec Clock (8MHz): For RMT
nDC_ALM	DC ALARM:DC alarm signal; Indicates the declined DC voltage. (L: Alarm condition)
DIN_RMT	Codec Data Input: For RMT
DOUT_RMT	Codec Data Output: For RMT
DQMLL (nWE0) DQMLU (nWE1) DQMUL (nWE2) DQMUU (nWE3)	Data Input/Output Mask (Write Enable): DQM signal for SDRAM and WE signal for each memory IC and ASIC
nDREQ0-1	DMA Request: For USB I/F
DSR2	Data Set Ready from RS-232C connector
DSR_RMT	Data Set Ready from RS-232C connector
DTR2	Data Terminal Ready to RS-232C connector
EC_AD[0] -[15]	Address of EC Synchronous Bus, Data Bus (4MHz)
EC_nCBE[1]-[0]	EC Bus Command/Byte Enable: The initiator drives as bus command in the address phase and as byte enable in the data phase.
EC_nCDET	EC Line Card Detection Signal Asynchronous interrupting signal
EC_CLK	Clock of EC Synchronous Bus (8MHz) All EC bus signals except nRESET/EC_INT operates in sync with this signal.
EC_nFRAME	EC Cycle Frame Signal: Indicates the drive by initiator and the execution of EC bus cycle.
EC_nINT	EC Interrupting Signal: Be asserted when slave interrupt occurs.
EC_PAR	Parity Bit of EC Synchronous Bus: Drive by applying even parity to AD[15:0] and CBE[1:0]. (4MHz)
EC_nPERR	EC Parity Error: Flag indicating error status by parity flag
EC_nRST	EC Reset Input: System reset input signal
EC_nSTOP	EC Bus Stop Signal: Be asserted when target requests transaction halt to initiator.
EC_nTRDY	EC Target Ready Signal: Indicates the drive by target and the possible data transfer.
nFAN_ALM	Fan Alarm: It goes Low at the error of the L Power Supply's FAN. It goes High when the FAN is normal and, Power Supply S and M, which does not carry the FAN, are used.
FSEL0	Signal which switches the Flash Memory address of the MEX card. FSEL0 is set by hard jumper. L: The number of Flash Memory chips on the MPR is 1pc. H: The number is 2pcs.
GAIN0-1	Gain: Gain adjustment signal for the RMT card (Reserve)
HALT	Alerts the occurrence of the declined DC voltage to line card. H: Active L: Normal
nINIT	System Initialization Switch Input: L: At system initialization, H: At normal start-up
nIRQ_ASIC	Interrupt Request from ASIC: Indicates ASIC requests interrupt.
nIRQ_SDB	Interrupt Request from SD card I/F: Indicates SD card I/F requests interrupt.
nIRQ_USB	Interrupt Request from USB I/F: Indicates USB I/F requests interrupt.

Signal Name	Functions														
LA[1] -[16]	Address bus														
nLB	Lower Byte Select: Indicates Lower byte select signal of SRAM														
LD[0] -[15]	Data Bus														
LDHW[1] -[0]	Down Highway: Data output terminal connected to codec etc. as down data signal of local highway														
nLEDALM	Alarm display L: On														
nLEDRUN	RUN display L: On														
nLOS	Loss of synchronous signal: Reserve at present														
LHWCLK[0]	Highway Clock Signal (8MHz): Bit clock of local highway and selectable among 2.048 / 4.096 / 8.192MHz.														
LUHW[1] -[0]	Up Highway: Data input terminal connected to codec etc. as up data signal of local highway.														
MASTER/nS	Master/slave identification signal when SIC card (Future Option) as intersystem connection card is mounted. MPR inputs this signal and detects which the MPR will be. H: Master L: Slave														
MD0-2	Mode Control Terminal: Clock operation mode of CPU is set.MD2: L, MD1: L, MD0: H Fixed														
MELODYSEL	Melody IC Tune Name Select L: Ju te veux H: Minuet														
MEX_MODE[0] -[3]	Information Bit to know the memory mounting capacity etc. of MEX card. Reserve at present.														
MOHSEL	Switching Signal between internal hold sound source and external hold sound H: Internal L: External														
Mu/nA	Switching Signal of Sound Compression Law H: Mu-Law, L: A-Law														
M/nS	TDA100, TDA200 Identification Signal set on the back board. The MPR inputs this signal and detects which the MPR will be. H: TDA200, L: TDA100														
POWTYPE[0] -[1]	Power Supply Type : <table border="1" style="margin-left: auto; margin-right: auto;"> <thead> <tr> <th rowspan="2"></th> <th colspan="2">POWTYPE</th> </tr> <tr> <th>[1]</th> <th>[0]</th> </tr> </thead> <tbody> <tr> <td>S Power Supply attached</td> <td>H</td> <td>H</td> </tr> <tr> <td>M Power Supply attached</td> <td>L</td> <td>H</td> </tr> <tr> <td>L Power Supply attached</td> <td>H</td> <td>L</td> </tr> </tbody> </table>		POWTYPE		[1]	[0]	S Power Supply attached	H	H	M Power Supply attached	L	H	L Power Supply attached	H	L
	POWTYPE														
	[1]	[0]													
S Power Supply attached	H	H													
M Power Supply attached	L	H													
L Power Supply attached	H	L													
nPRS_MEX	Press MEX: Information of MEX Card Attachment L: Attached, H: Not attached														
nPRS_RMT	Press RMT: Information of RMT Card Attachment L: Attached, H: Not attached														
nPRS_SDB	Press SD card: Information of SD Card Attachment L: Attached, H: Not attached														
nRAS3L	Lower Byte Address Row Address Strobe: RAS signal for SDRAM														
nRAS3U	Upper Byte Address Row Address Strobe: RAS signal for SDRAM														
nRD	Read: USB I/F, SD card I/F, ASIC, SRAM, Read signal for flash memory														
RD/nWR	Read/nWrite: Read/Write signal for SDRAM														
nRESOUT	Reset Out: Reset from CPU (IC101) to each card														
nRESET	Reset: Power-on reset signal														
nRESETM	Manual Reset: Manual reset request signal for CPU														
RINGER	Ringer Signal: Outputs square-wave of 16Hz/20Hz/25Hz as source signal of ringer														
RING_SYNC	Trigger Signal of Ringer Signal generation timing to each internal line card														
nRTS2	Request To Send to RS-232C connector														
RTS_RMT	Request to Send: Flow signal for modem														
RXD2	Receive Data from RS-232C connector														
RXD_RMT	Serial Data Output Terminal: ASIC														
SDCD	SD Card Detect Input														
SDCLK	SD Card Clock Out														
SDCMD	SD Command														
SDDAT0-3	SD Card Data														
SDWP	SD Card Write Protect Input														
SHW_CLK	Intersystem Highway Clock Signal (4MHz) Bit clock of intersystem highway and selectable between 256KHz/512KHz/1.024MHz/2.048MHz/4.096MHz.														
SHW_FH	Intersystem Highway Synchronous Signal (8KHz) 8KHz frame synchronous signal of intersystem highway														
TXD2	Transmit Data to RS-232C connector														
TXD_RMT	Serial Data Input Terminal: Data receiving terminal from RMT to UART in the ASIC														
nUB	Upper Byte Select: SRAM														
USB_D+	USB Data +														
USB_D-	USB Data -														
VBUS	Bit indicating power source is supplied to USB bus [Host (PC etc.) is connected.] H: Host connected L: Host not connected														
VREF	Reference Voltage for MOH Circuit Intermediate potential of +15V														
nWAIT	Wait: Hardware wait request signal for bus timing between CPU and ASIC														
WDTCLR	Reserve														
nWE	Write Enable: WE signal of SRAM														

- ASIC block

Configuration: IC102 (ASIC), IC111, X103 and so on.

Function: (IC102)

Functions as the bus master of EC bus (synchronous bus with 16 bit width, transmission rate max.10Mbps). Communicates with ASIC mounted to each option card via EC bus and controls the option card.

Controls CT bus (HW clock 8.192MHz, 8 highway, 128 timeslot) for TSW function.

(A detailed description of TSW will be added later.)

Controls the conference call for 3 people x ~8 parties ~ 8 people x ~3 parties.

Generates single and DTMF tone in any highway and timeslot.

Provides the digital gain control function by data conversion.

Provides some I/O ports for CODEC channel pulse generation, modem encoding rule setting and music on hold switching and is controlled by CPU.

- Memory block

Configuration: IC301, IC302 (SRAM), IC303 (FlashROM), IC305, IC306 (SDRAM), IC309, IC310, IC311 (logic IC) and so on.

Function: (IC301, IC302)

Saves the user configuration data (such as key assign data per PT).

This memory is battery backup.

(IC303)

Saves (some of) the system boot program and the system data.

(IC305, IC306)

The main program is loaded from the SD card on the system start-up.

Used as the program area and the CPU work area after start-up.

Makes a direct bus connection to CPU due to high-speed action (bus clock 66MHz).

(IC309, IC310, IC311)

Generates each memory select signal from the memory area select signal and upper address. Generates the write signal and upper/lower byte select signal.

- USB block

Configuration: IC204 (USB I/F), X201 (source clock: 12.000MHz), CN209 (USB connector) etc.

Function: Connects to the USB host system (mainly PC) via CN209 (B type connector) as a USB device and makes data transfer by max.11Mbps. DMA function of CPU is utilized to transfer the data.

- SD card block

Configuration: IC205 (SD card I/F), IC209, X202(20MHz), CN211 (SD card connector) and so on.

Function: Loads the main program and the system data from the SD card connected to CN211 by 10Mbps. Restores the system data periodically.

- MOH/PAGING block

Configuration: IC405, IC406 (CODEC), IC408, IC409 (OP Amp), IC410 (Melody IC), Q407~Q410 (transistor), JK401~JK404 (pin jack) etc.

Function: The external music on hold 1 is input from JK404 and is A/D converted in IC405 via AGC (Auto Gain Control) circuit, which consists of IC408, Q407, Q409 and other CR, and then is connected to the call line HW. Likewise the external music on hold 2 is input from JK403 and is made A/D conversion in IC406 via AGC (Auto Gain Control) circuit, which consists of IC409, Q408, Q410 and other CR, and then is connected to the call line HW. The external music on hold 2 and IC410 is exclusively connected to IC406 input (by software control).

The various tones & DTMF tone and the voice data generated in IC102 (ASIC) are made D/A conversion in IC405 and IC406. They are output via JK402, JK401 respectively.

- Power Supply block

Configuration: IC402 (DC/DC converter), IC403 (1.8V regulator), IC404 (1.9V regulator), IC411 (OP Amp), IC413 (negative power regulator), Q403, Q404, Q405, Q411, Q412 (transistor), L401, C408, C453, C454, D406~D409, BAT401, IP401, IP402 (circuit protection device) and so on.

Function:

+15V input is made step-down to +3.3V by DC/DC converter circuit that consists of IC402, L401, Q412 and C408, and is supplied to each IC power. Also, it monitors +3.3V output voltage and turns ON Q411 to block +15V input when over voltage is supplied.

+15V input is dropped to +9.4V by Q403 and is supplied to RS232C driver with the inverted voltage (about 9.1V) generated in IC413, C453 and C454.

+3.3V generated in DC/DC converter is converted to 1.8V in the back board or IC403 and Q405 via Q404 and supplied to IC101 core power, and also is converted to 1.9V in IC404 via the back-flow prevention diode D407 and supplied to IC101

clock block power.

BAT401, which is a lithium battery for memory backup, is connected to the power supply of IC301, IC302 (SRAM) via D408, D409.

IC411 compares BAT401 output voltage to the reference voltage (about 2.8V) and drives LED (BATALM) that indicates dropping of backup voltage.

IP401 and IP402 block the line respectively when over current flows to +15V and +3.3V line.

10 BACK BOARD CIRCUIT OPERATION

The back board (BB) connects signals between all cards in main unit. It also supplies power from the power supply unit (PSU) to the cards.

CONNECTORS EXPLANATION

(1) Power Supply Unit Connector: CN100

(2) Free Slot Connectors: CN101-CN110

(3) Option Card Slot Connector: CN111

(4) MPR Card Connector: CN112

(5) RS-232C Connector: CN113

CN113 is connected to D-Sub connector in front of the product.

(6) LED Connector: CN114

CN114 is connected to LED Board on the product.

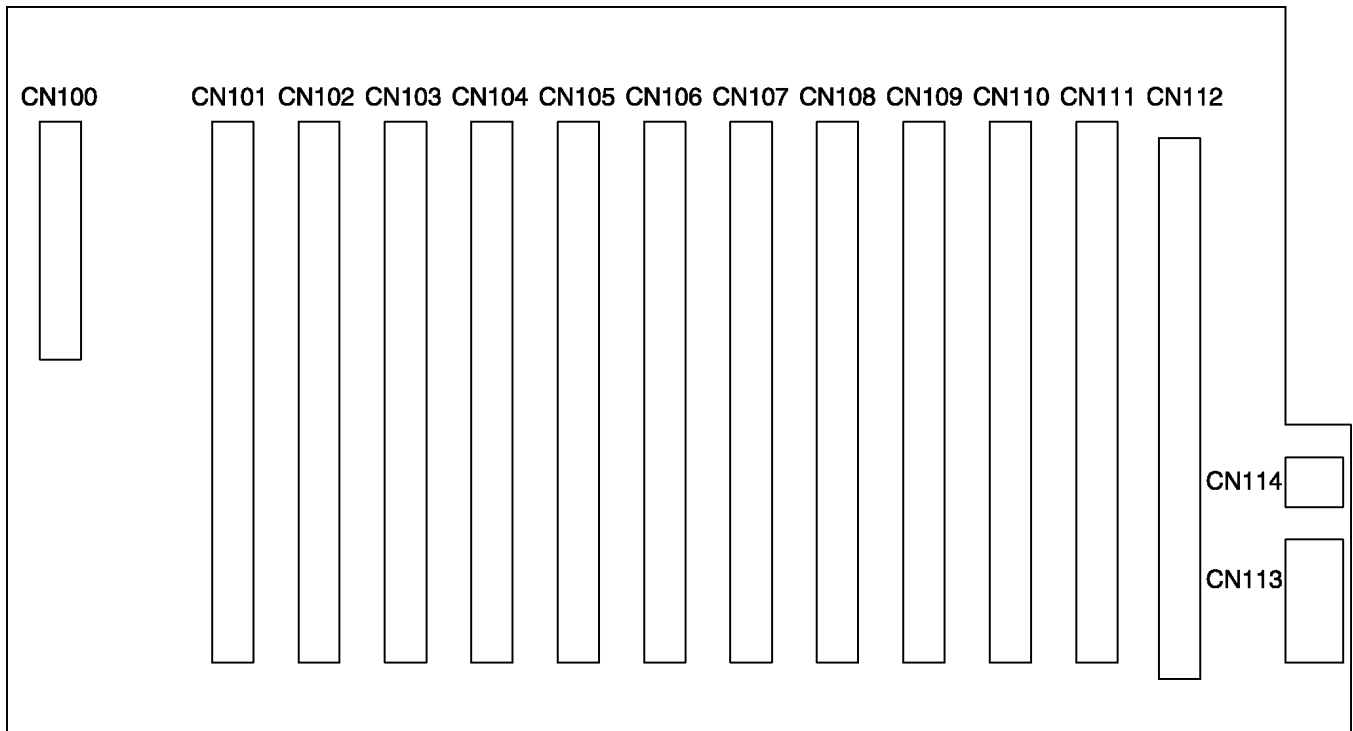

11 TROUBLESHOOTING GUIDE

11.1. INTRODUCTION

First, check which part of the system is causing the trouble. Follow the flowchart provided below, and replace each unit in turn with a working unit to identify the damaged unit.

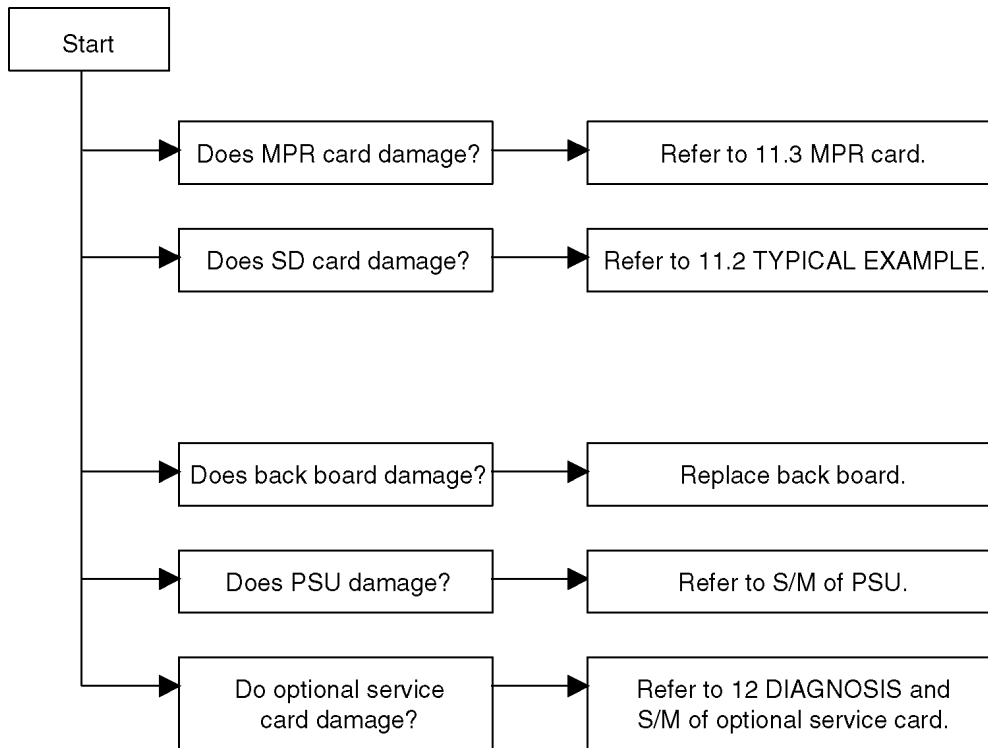

Even when damaged unit is found out, it may mean that not the cause in the unit but the damaged cause in another unit.

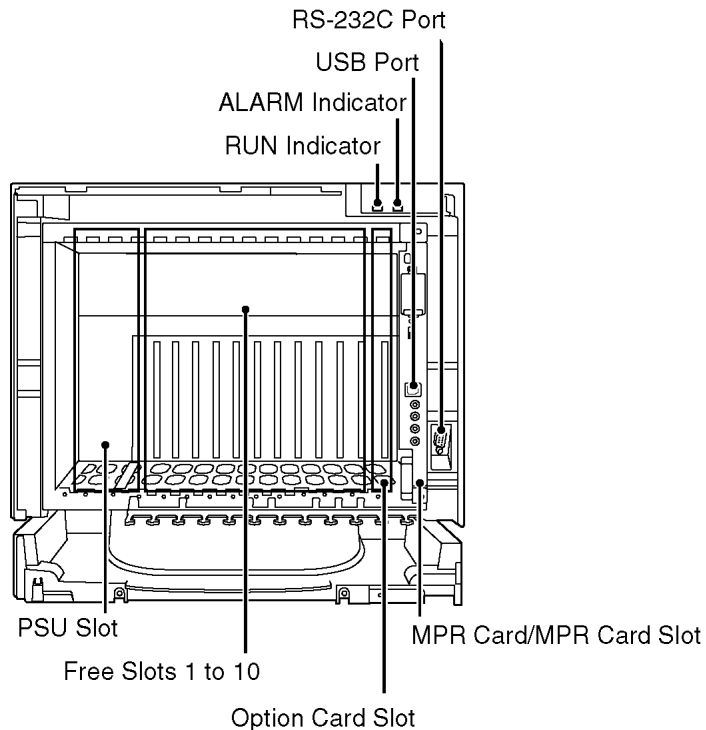

11.2. TYPICAL EXAMPLE

The following items are typical examples when defective occur in main unit. The analysis work first shown in this chapter is done. When you do not correspond to this chapter, or when analysis is not completed, move to the following chapter.

	Symptom	Checkpoint
1	<p>Even if main power switch turns on, all LED (Power indicator, RUN-ALARM indicator, BATT ALARM, SD ACCESS, and other option cards LED) do not light at all.</p> <p style="text-align: center;">↓</p> <p>It is also considered that the protection circuit operated as for the cause of this phenomenon. Since main unit detects of the external abnormalities in temperature or the external fault voltage input from the outside besides the main unit damage. Since the phenomenon by protection operation has a cause in the exterior of main unit, remove first of all not main unit but an external factor.</p>	<p>1) Check whether AC power supply is inputted normally. ↓</p> <p>2) Main Power switch turns off, and after waiting 20 seconds or more, it turns on again. -- Release of PSU OVP (Over Voltage Protection). It checks that the temperature of the front surface of PSU is 104°F (40°C) or less, and turns on. -- Release of PSU OTP (Over Temperature Protection). ↓</p> <p>3) Check whether the fuse of PSU is blowned. -- Refer to S/M of PSU. ↓</p> <p>4) When the optional service cards are attached: Is the analog CO line incorrect-connected to the extension card?</p>
2	<p>When Main Power switch carries out ON, only power indicator of PSU light, and LED (RUN-ALARM indicator and BATT ALARM SD ACCESS) of main unit and MPR card does not light at all.</p>	<p>Check IP401 or IP402 on MPR card. ↓</p> <p>If the parts (IP401 or IP402) is blowned, exchange it.</p>
3	<p>The trouble about SD Card</p> <ul style="list-style-type: none"> ▪ Don't access to SD card after the main power supply ON. ▪ Although access is carried out, don't complete of system starting. ▪ A system setup was initialized. 	<ul style="list-style-type: none"> ▪ Is SD card inserted in the connector exactly? ▪ Isn't write-protection of SD card Locked? ▪ Aren't SD cards other than enclosed SD card used? -> Depending on format form, it may not operate on main unit. ▪ Has not SD card broken? <p>Note: Having, when a system setup has been initialized by incorrect operation etc., a system setup recommends what backup is taken for to PC etc.</p>
4	<p>ALARM Indicator lighted.</p>	<p>ALARM indicator To Error log (Major) Although it light if there is at least one item, what Error log notifies the state change other than an unusual notice to is not contained, and not all necessarily show the failure state.</p> <p>In judging abnormalities by ALARM indicator, check the contents of Error log and judge whether it is failure. Refer to 11.4 ERROR LOG.</p>

11.3. MPR CARD

11.3.1. Startup

Run indicator (LED201)

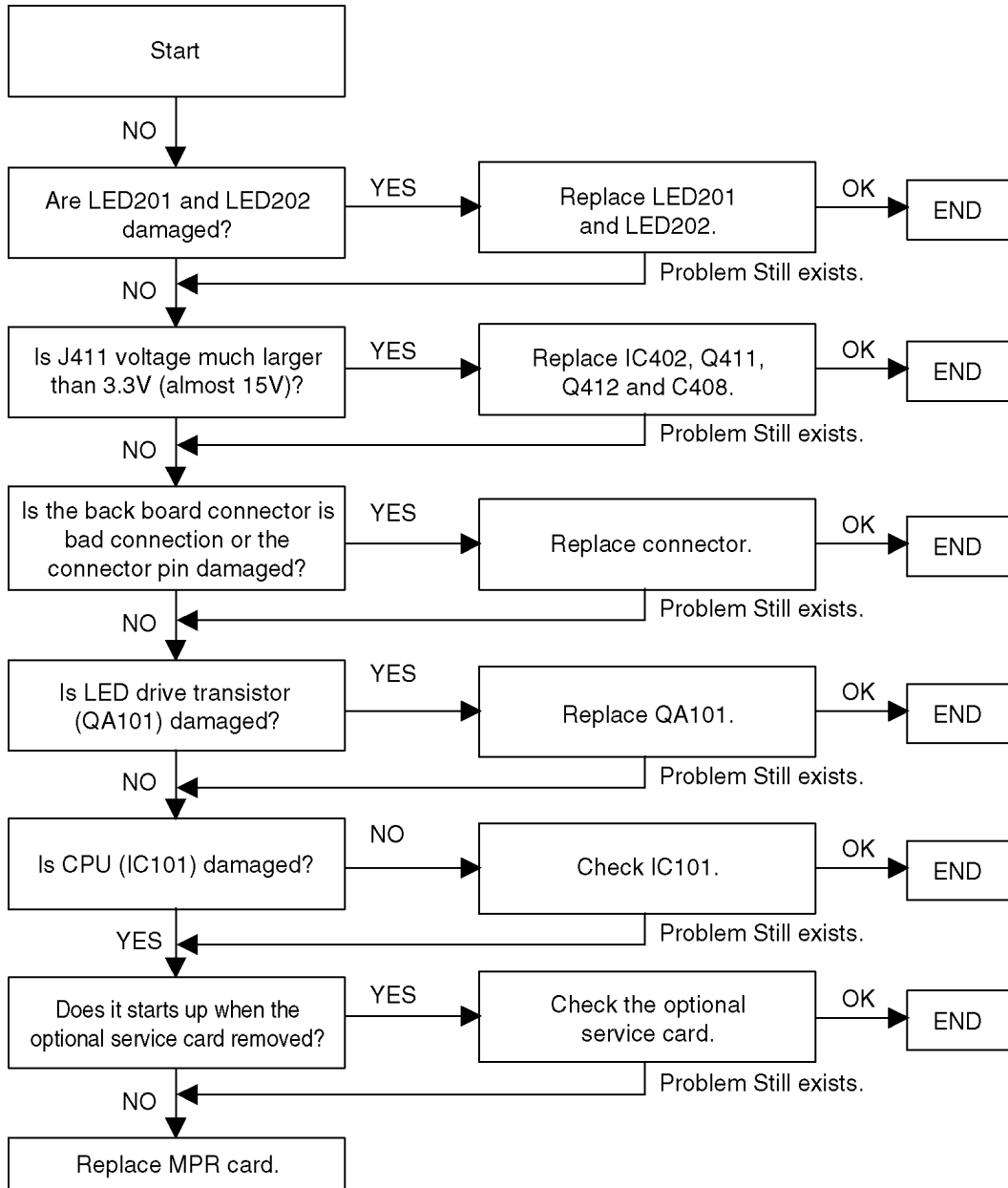

SD card access light does not flash

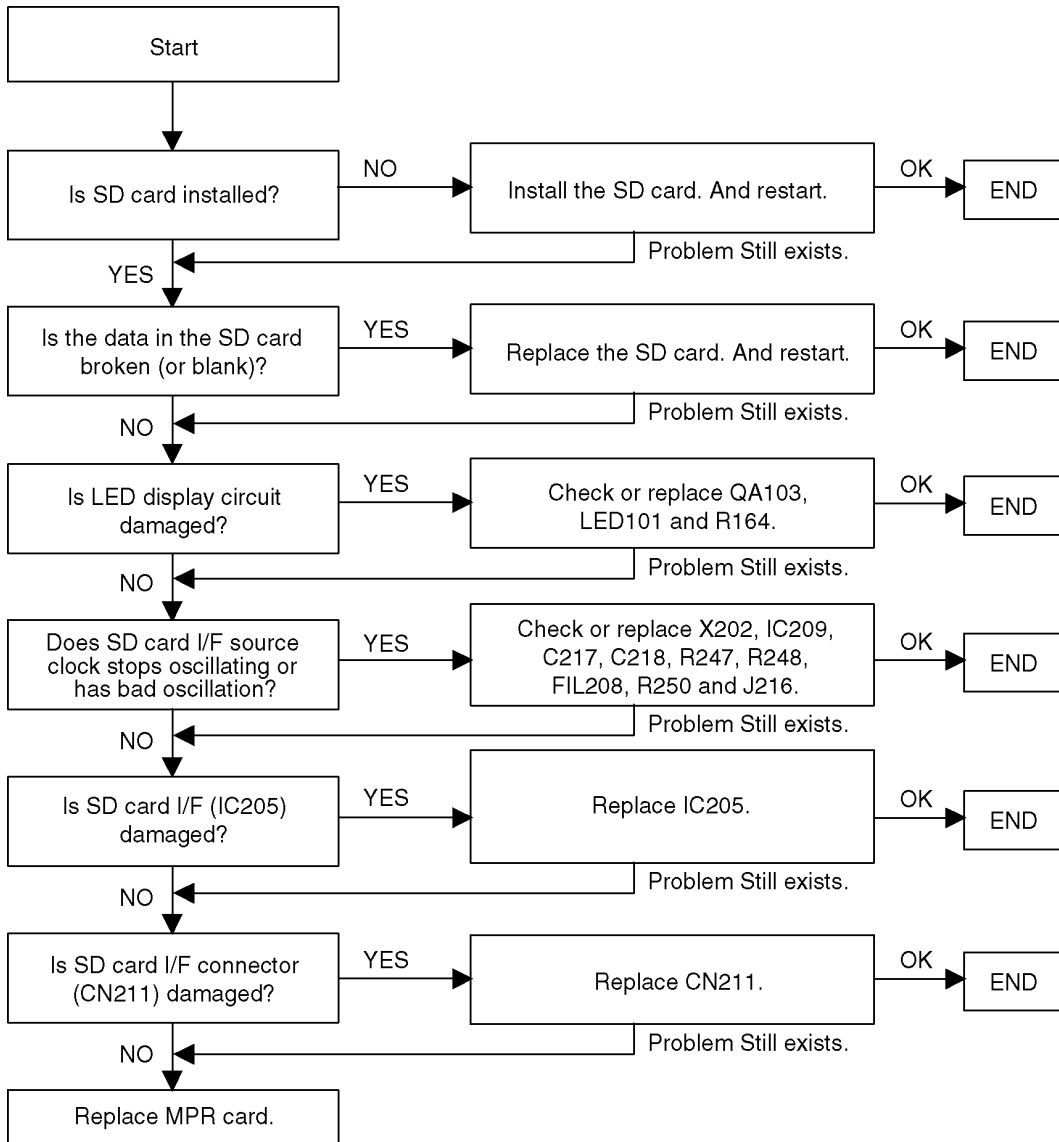

The battery alarm indication light turns on

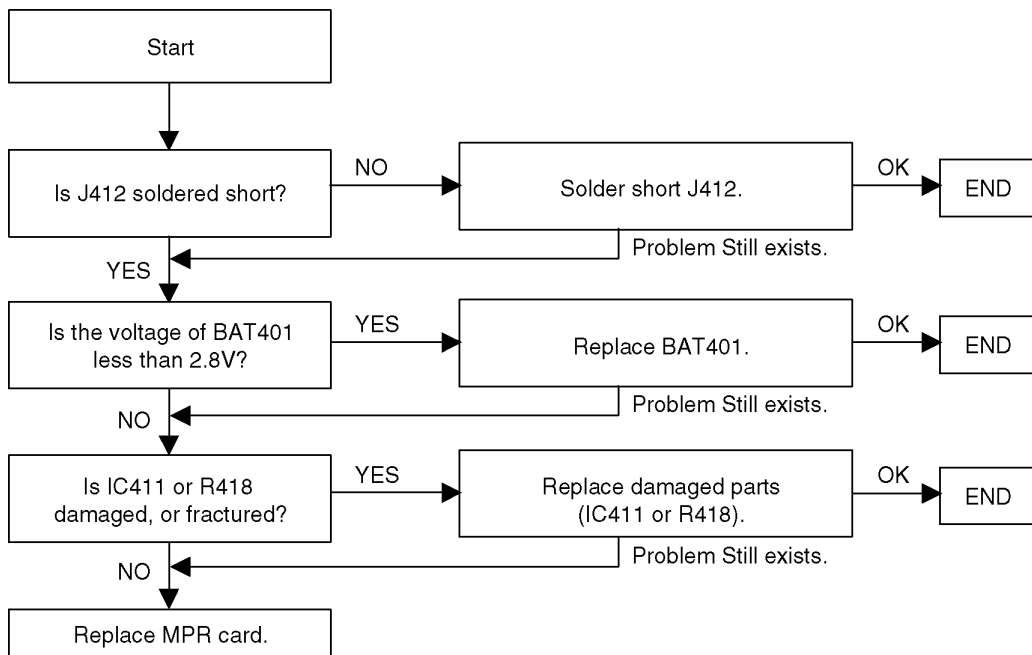

ALARM indicator flashes

- 1 blink and 1 interval
 - 2 blinks and 1 interval
- (1 blink is 0.5 sec. ON and 0.5 sec. OFF. 1 interval is 2 sec.)

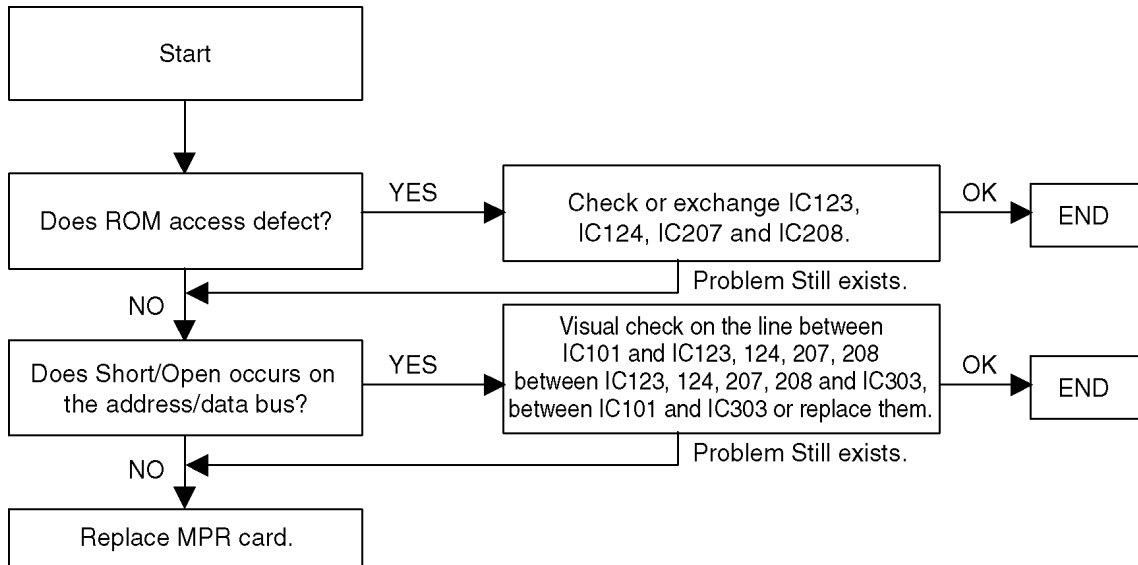

ALARM indicator flashes

- 3 blinks and 1 interval
 - 4 blinks and 1 interval
 - 5 blinks and 1 interval
- (1 blink is 0.5 sec. ON and 0.5 sec. OFF. 1 interval is 2 sec.)

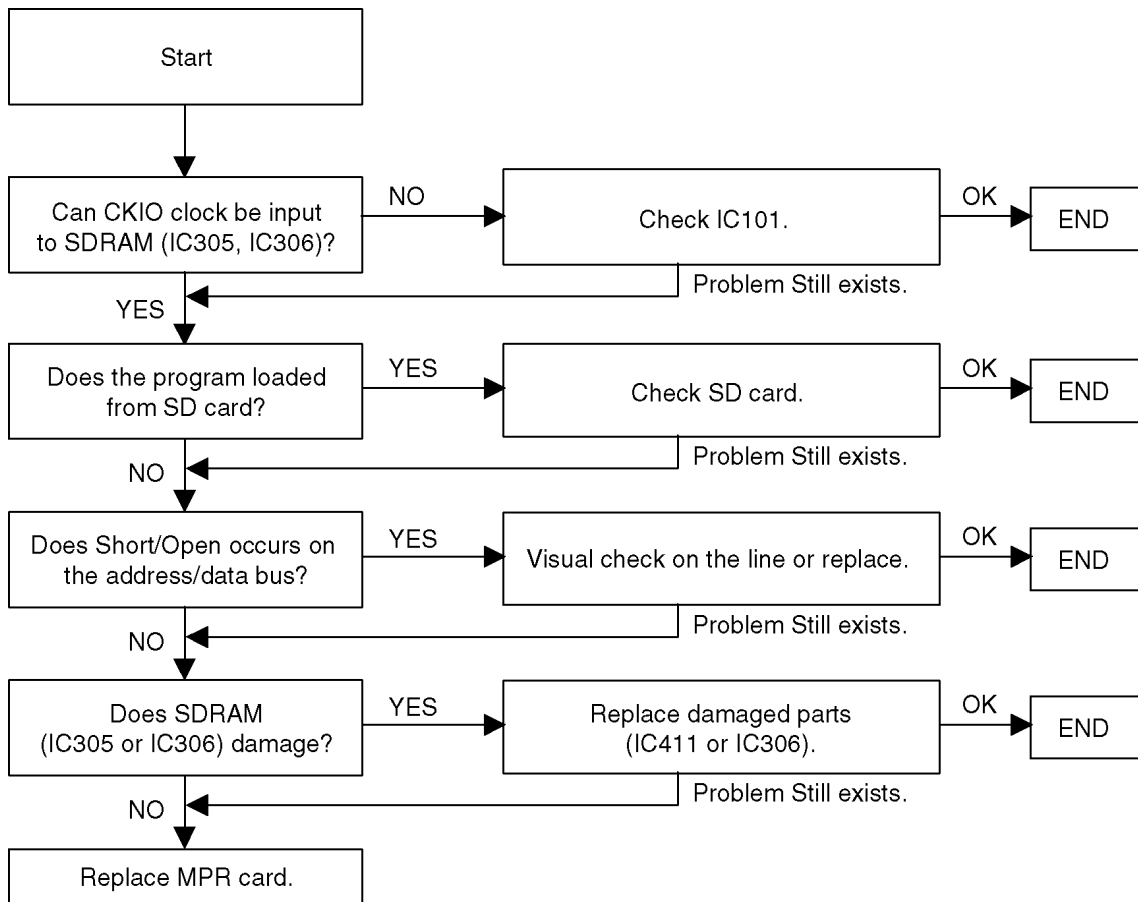

Optional service cards cannot start up

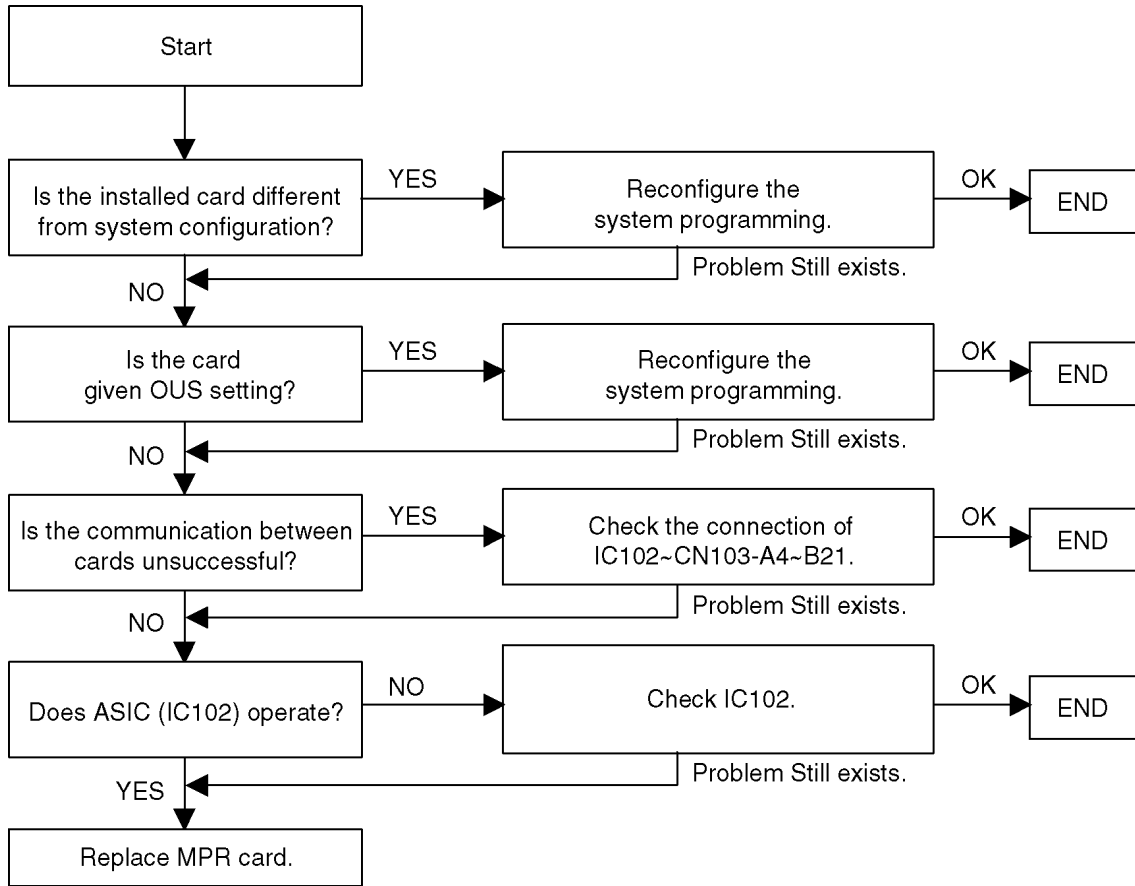

11.3.2. Phone Call

The call path cannot connect

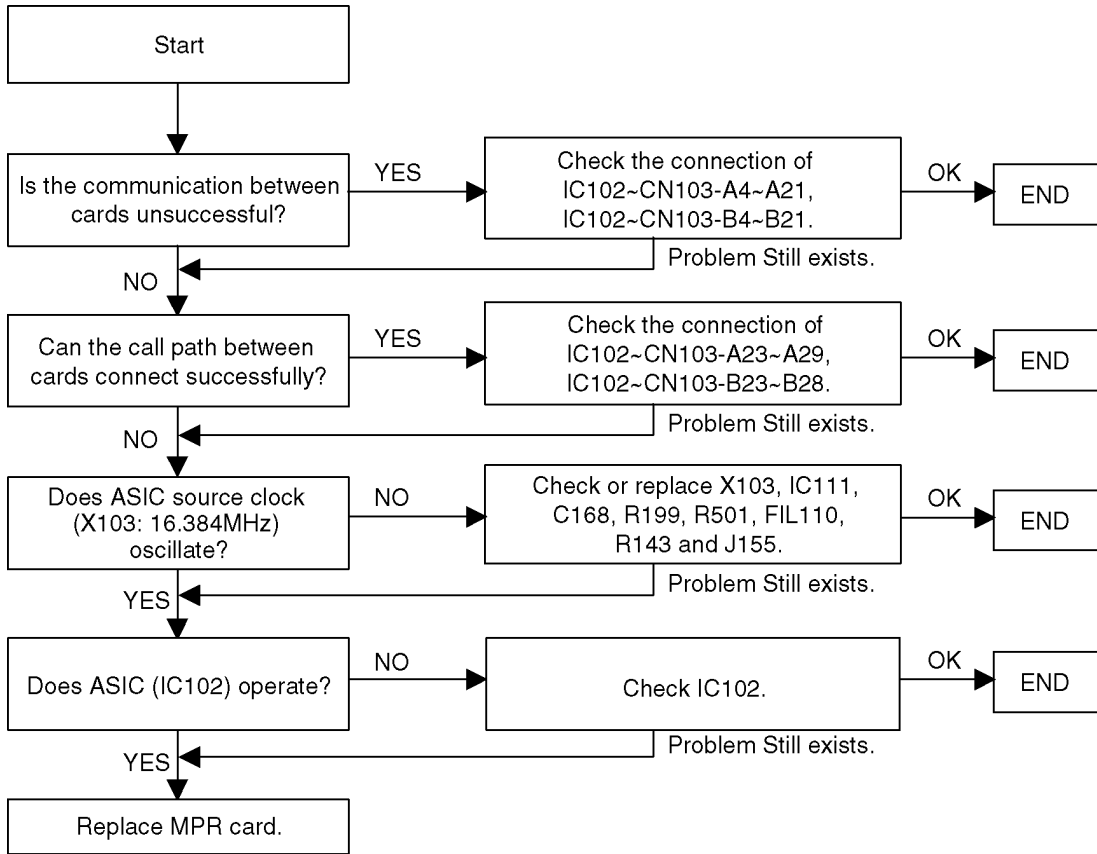

Noise is created

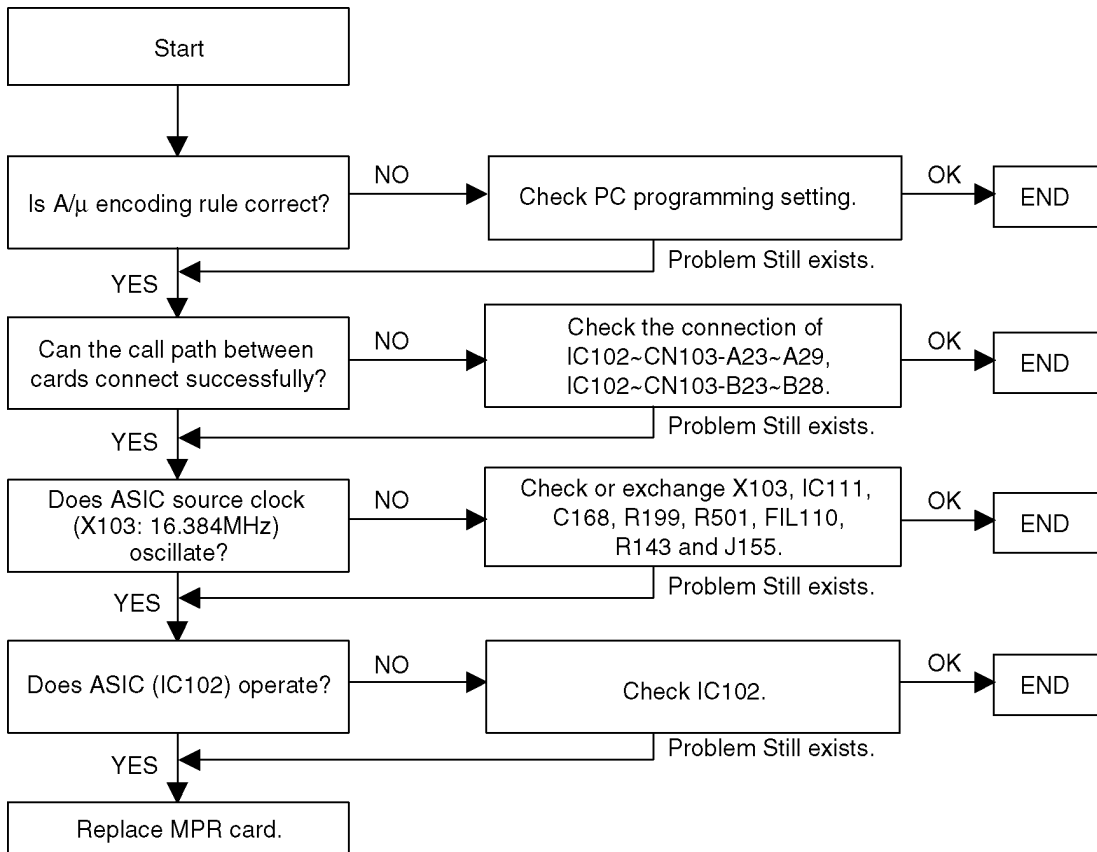

11.3.3. Paging

No sound (PAGING1)

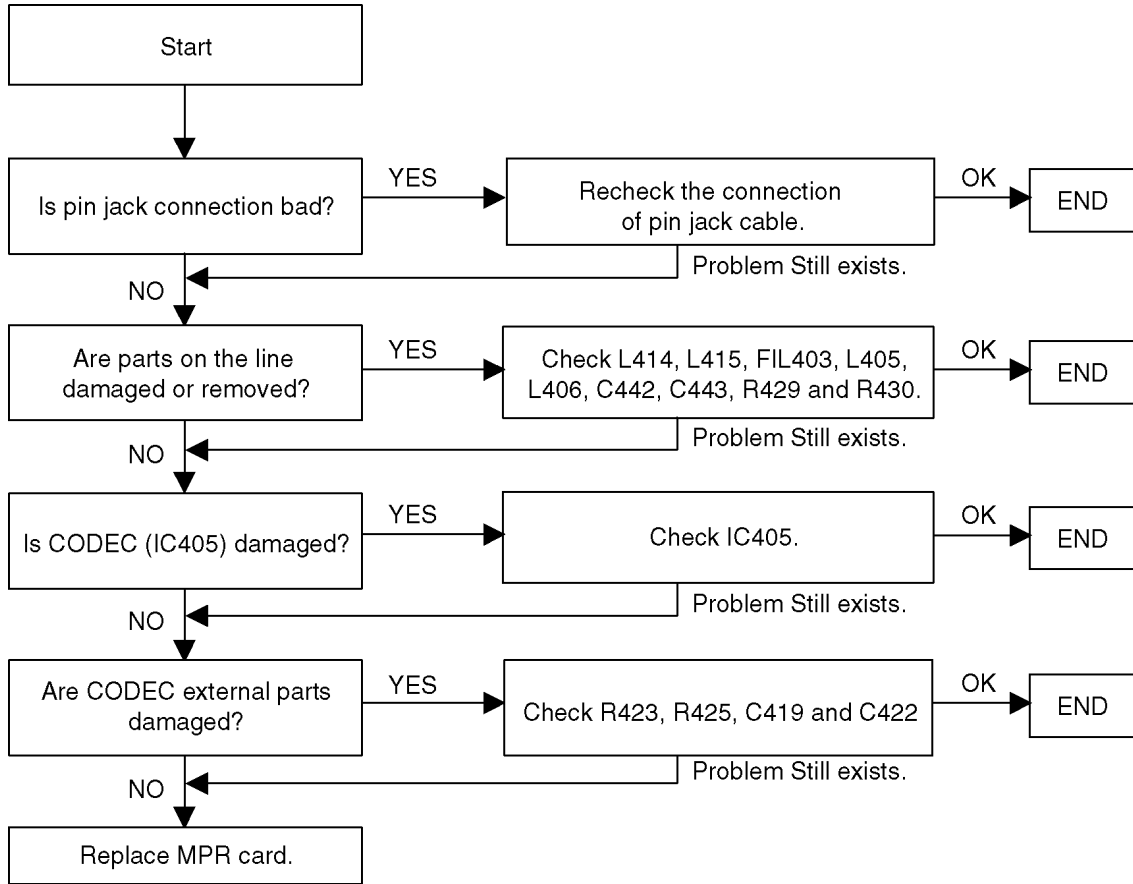

No sound (PAGING2)

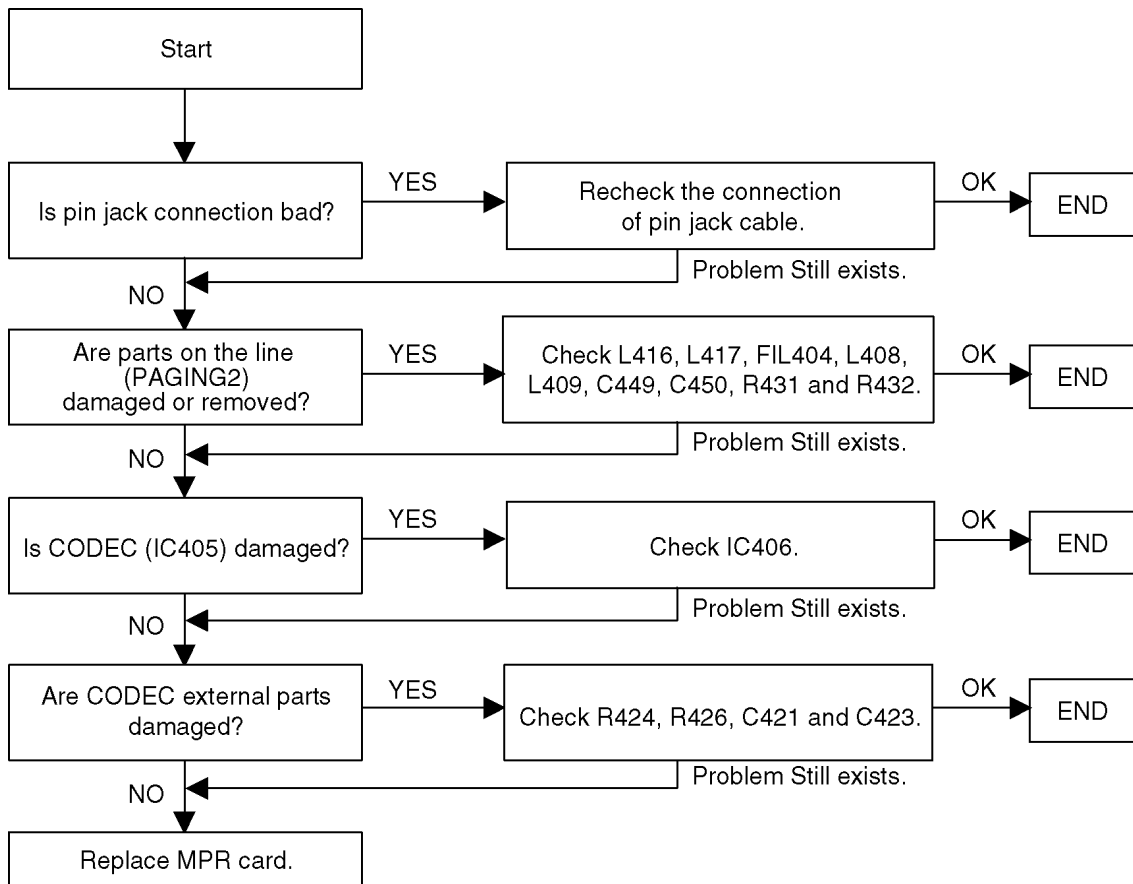

Noise is Heard (PAGING1)

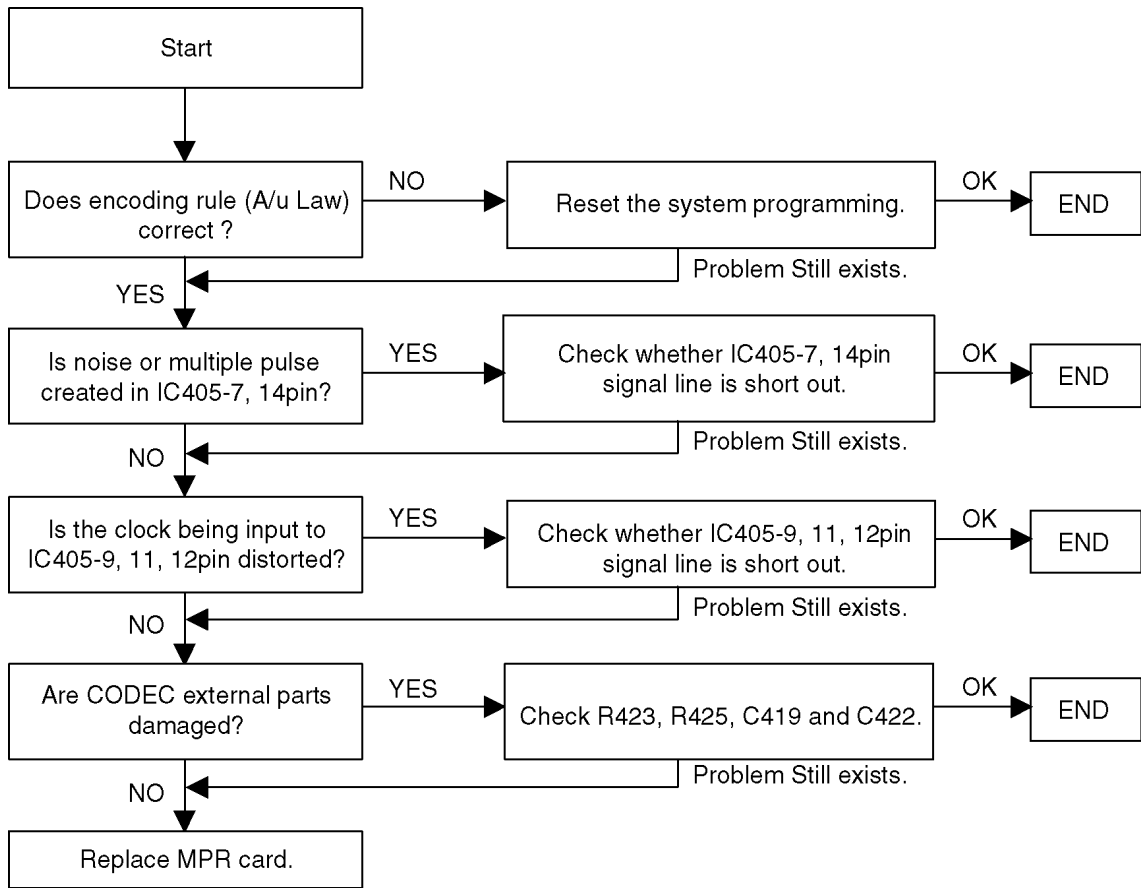

Noise is Heard (PAGING2)

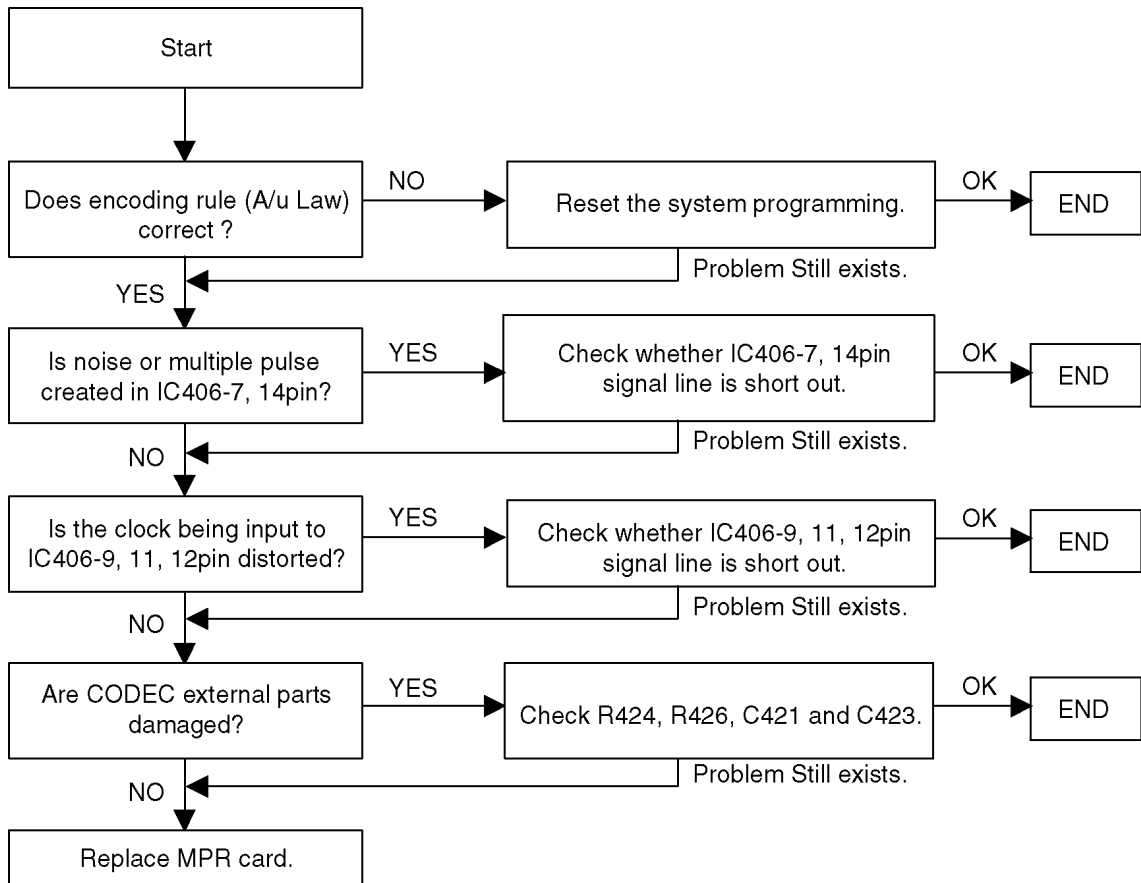

Sound is small (PAGING1)

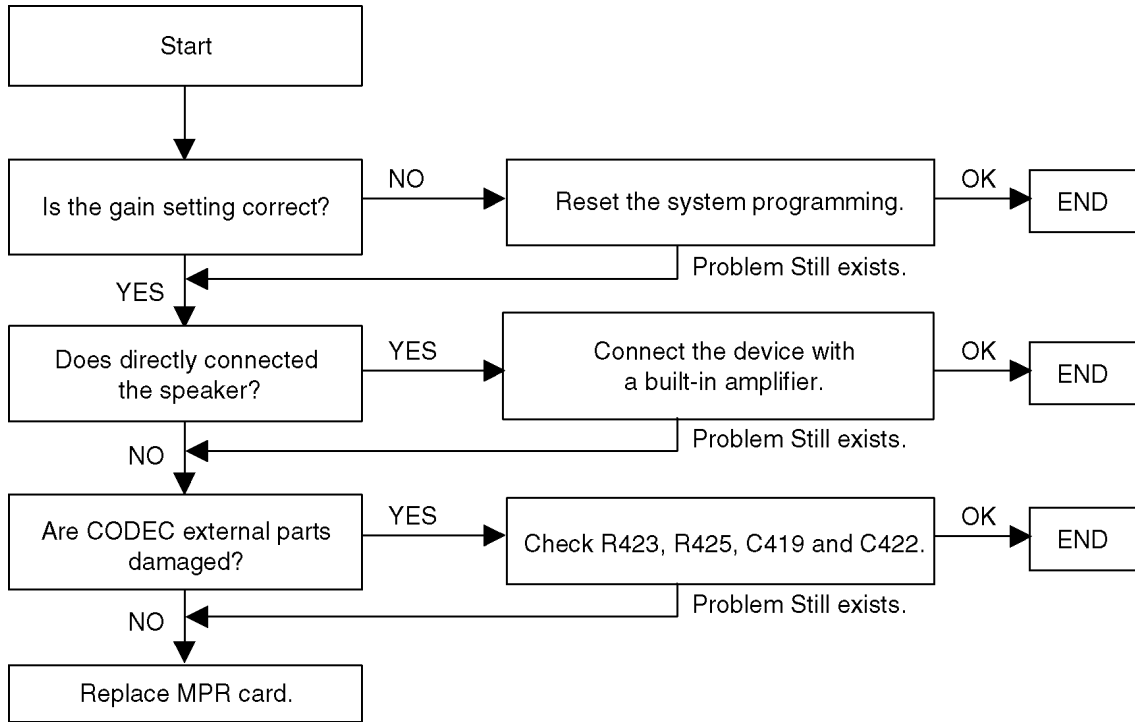

Sound is small (PAGING2)

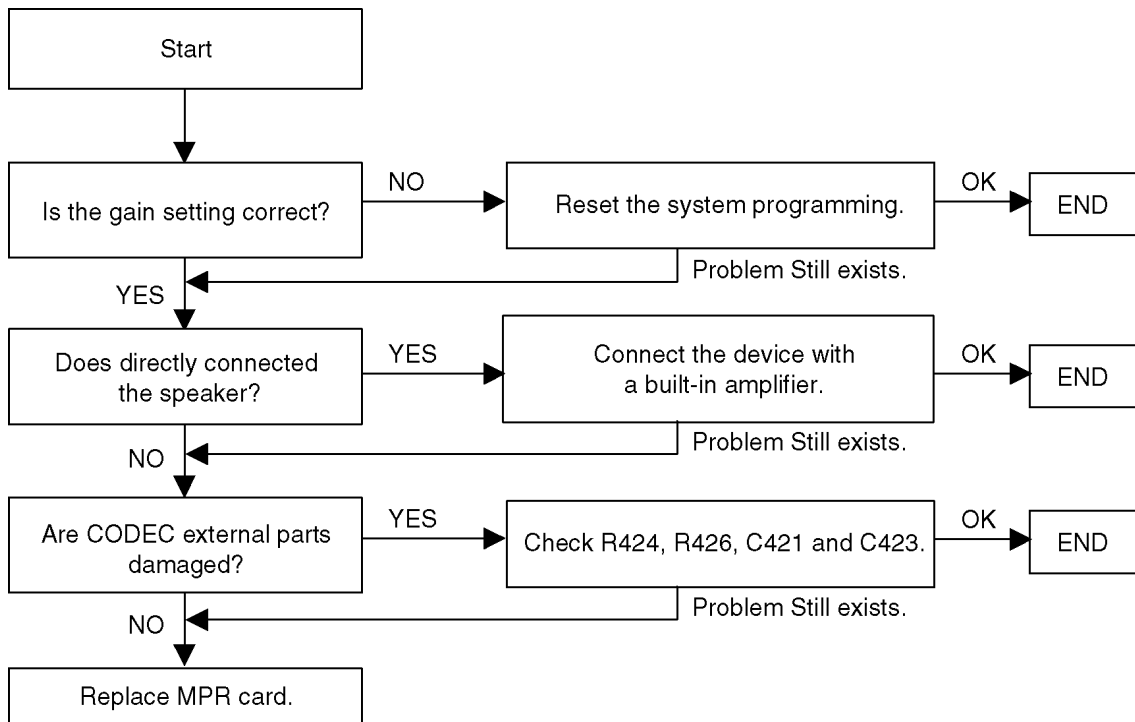

11.3.4. MOH Using

No sound is heard (MOH1)

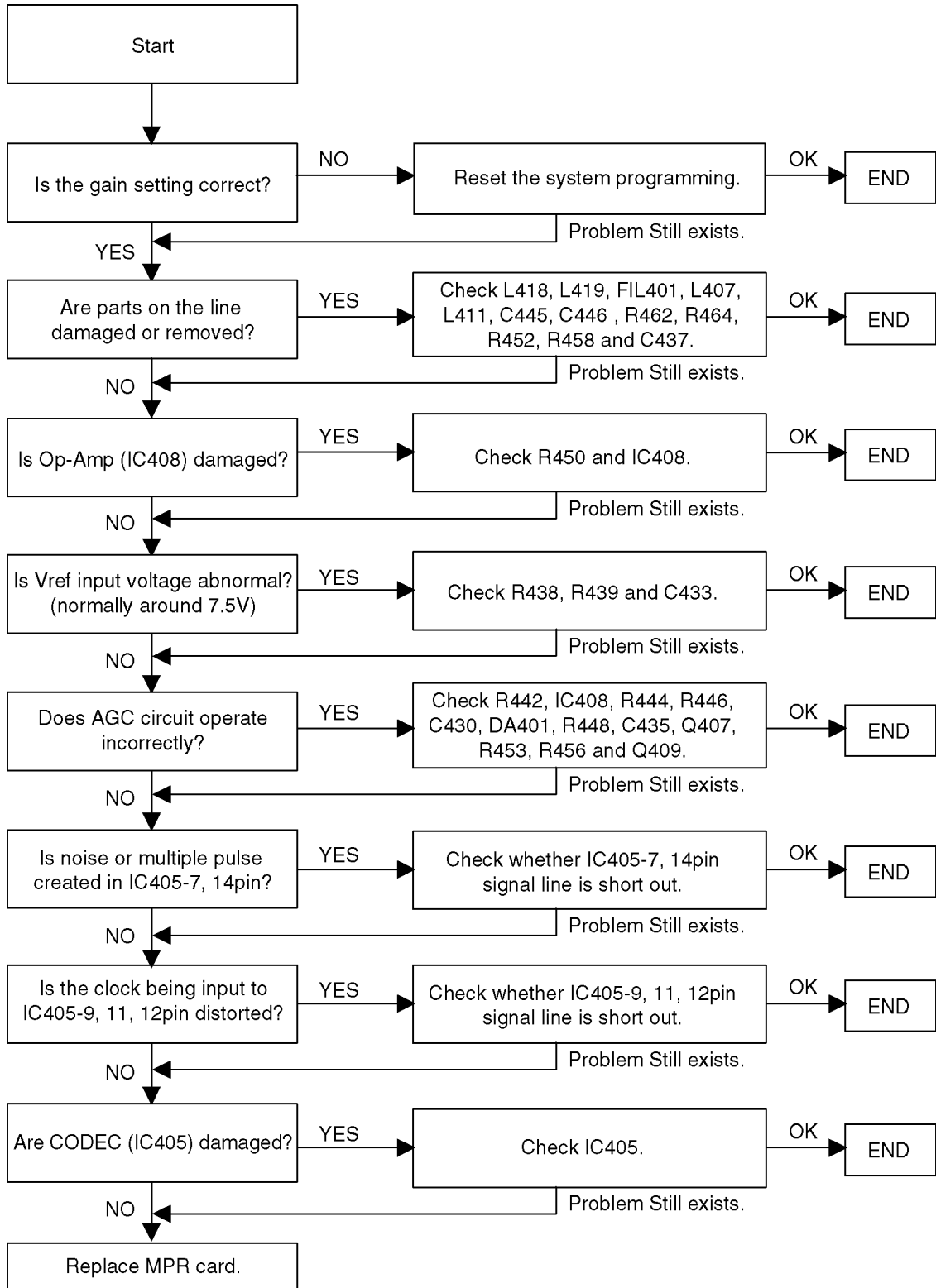

No sound is heard (MOH2)

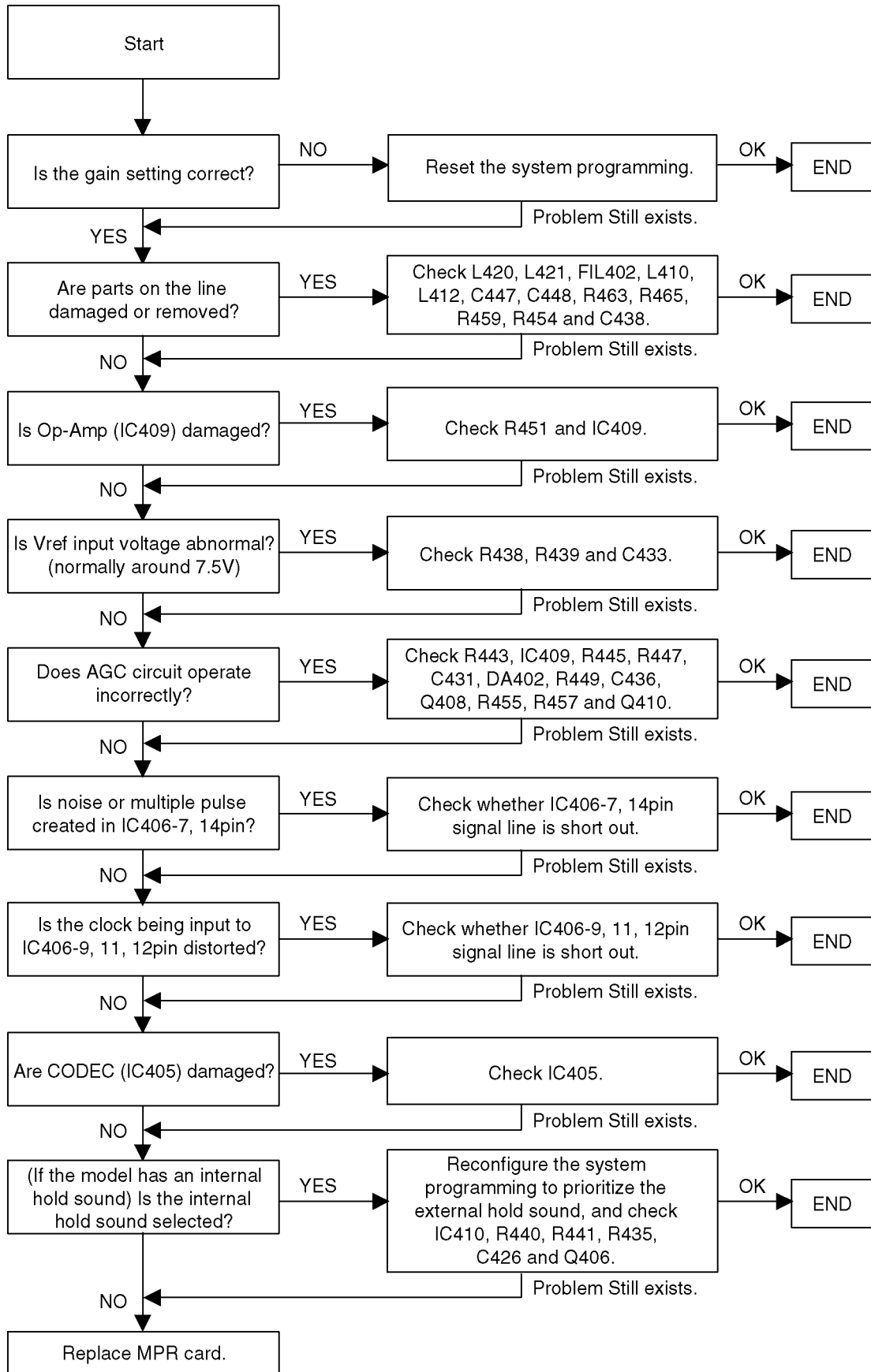

Sound is small or loud (MOH1)

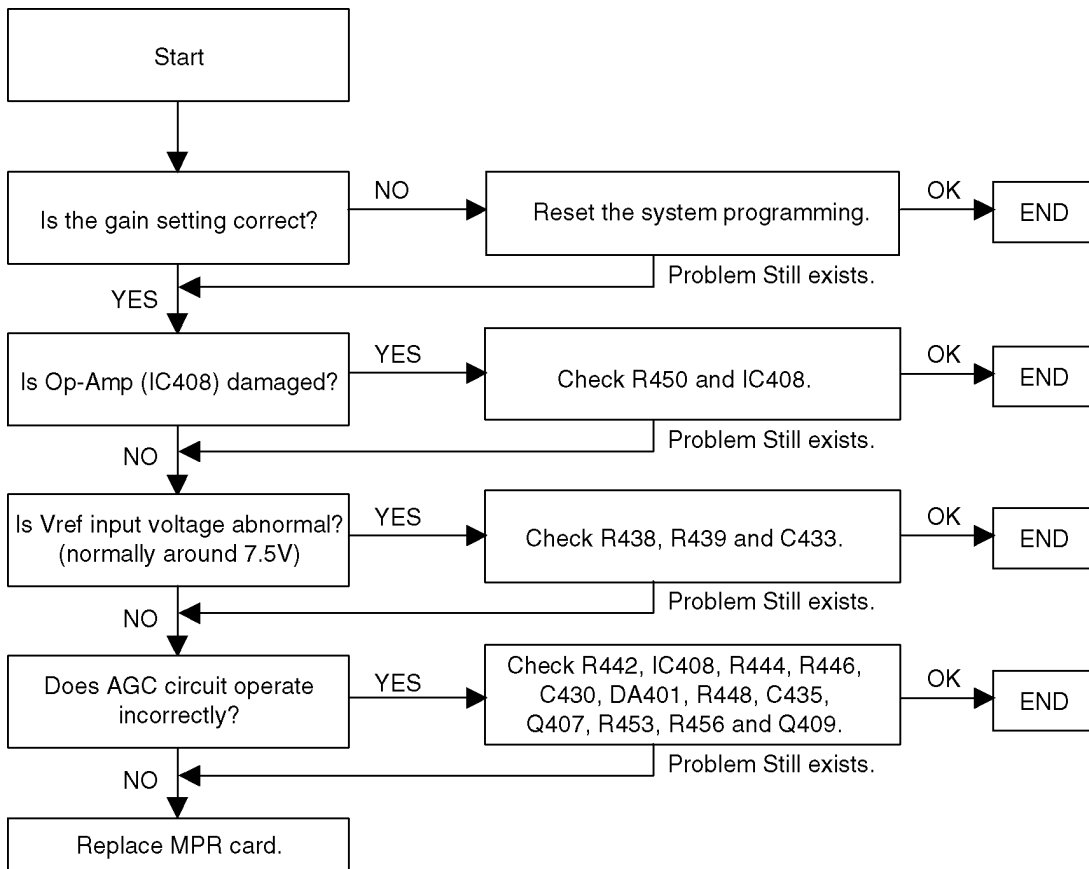

Sound is small or loud (MOH2)

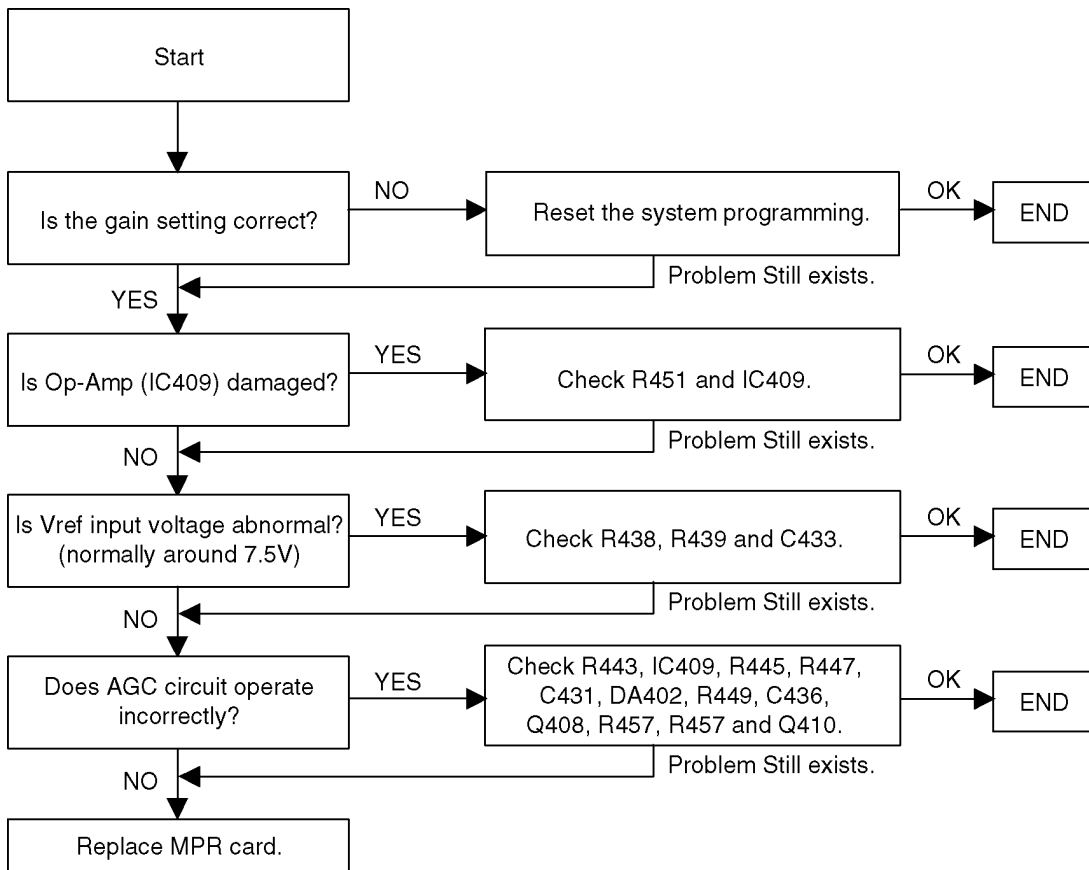

11.3.5. USB Connection

Unable to connect

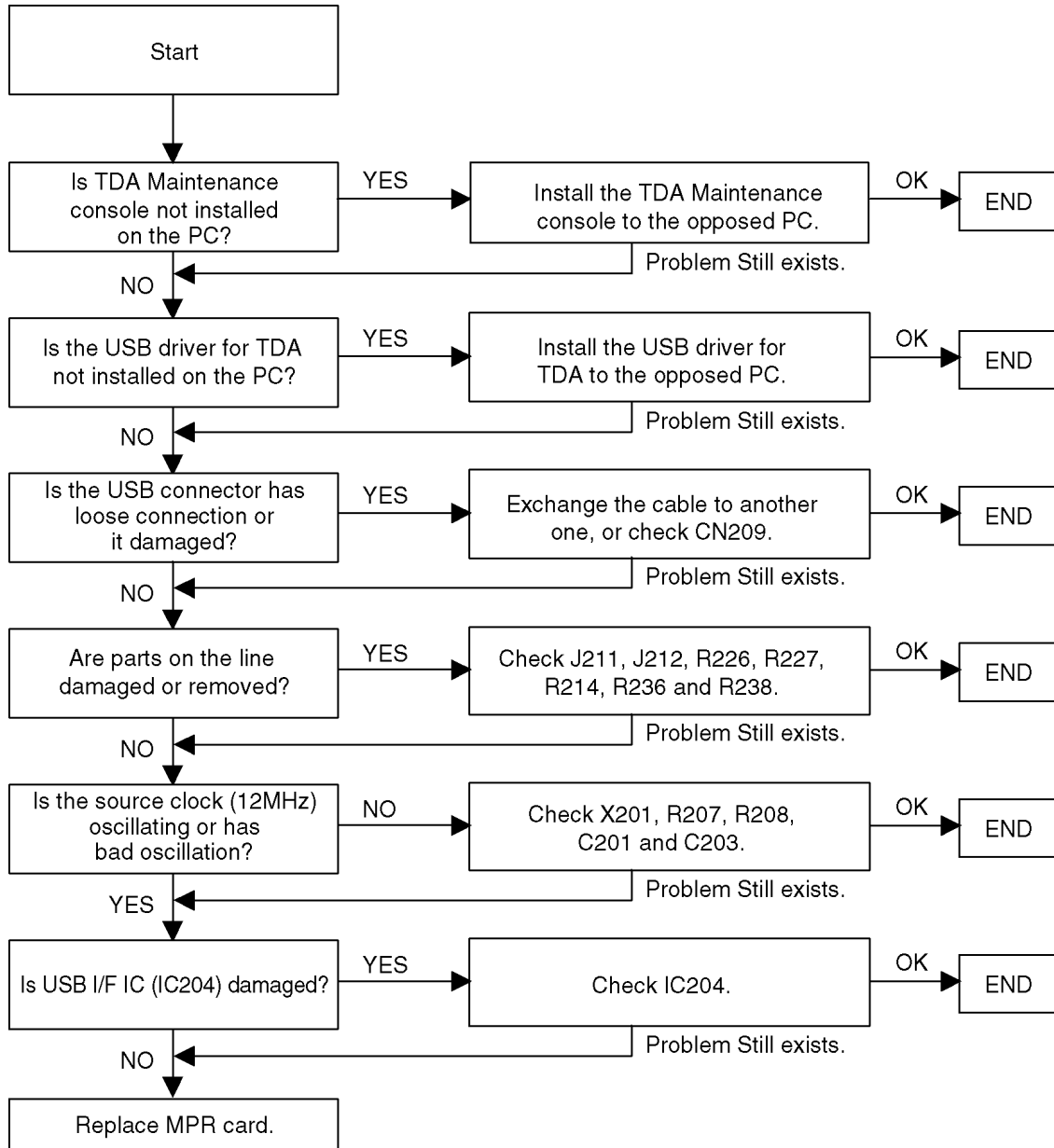

Connection error occurs

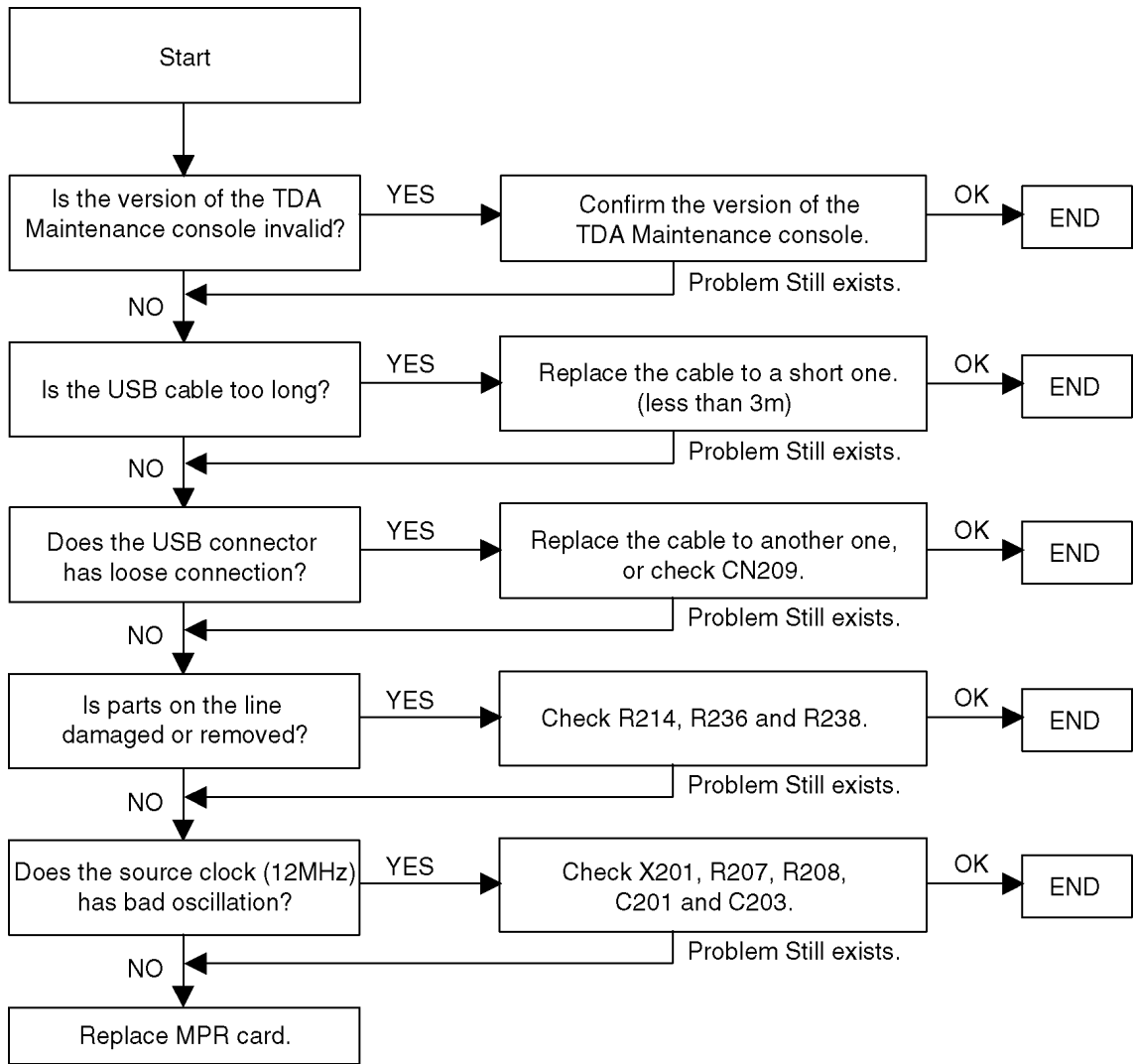

11.3.6. RS-232C Connection

Unable to connect

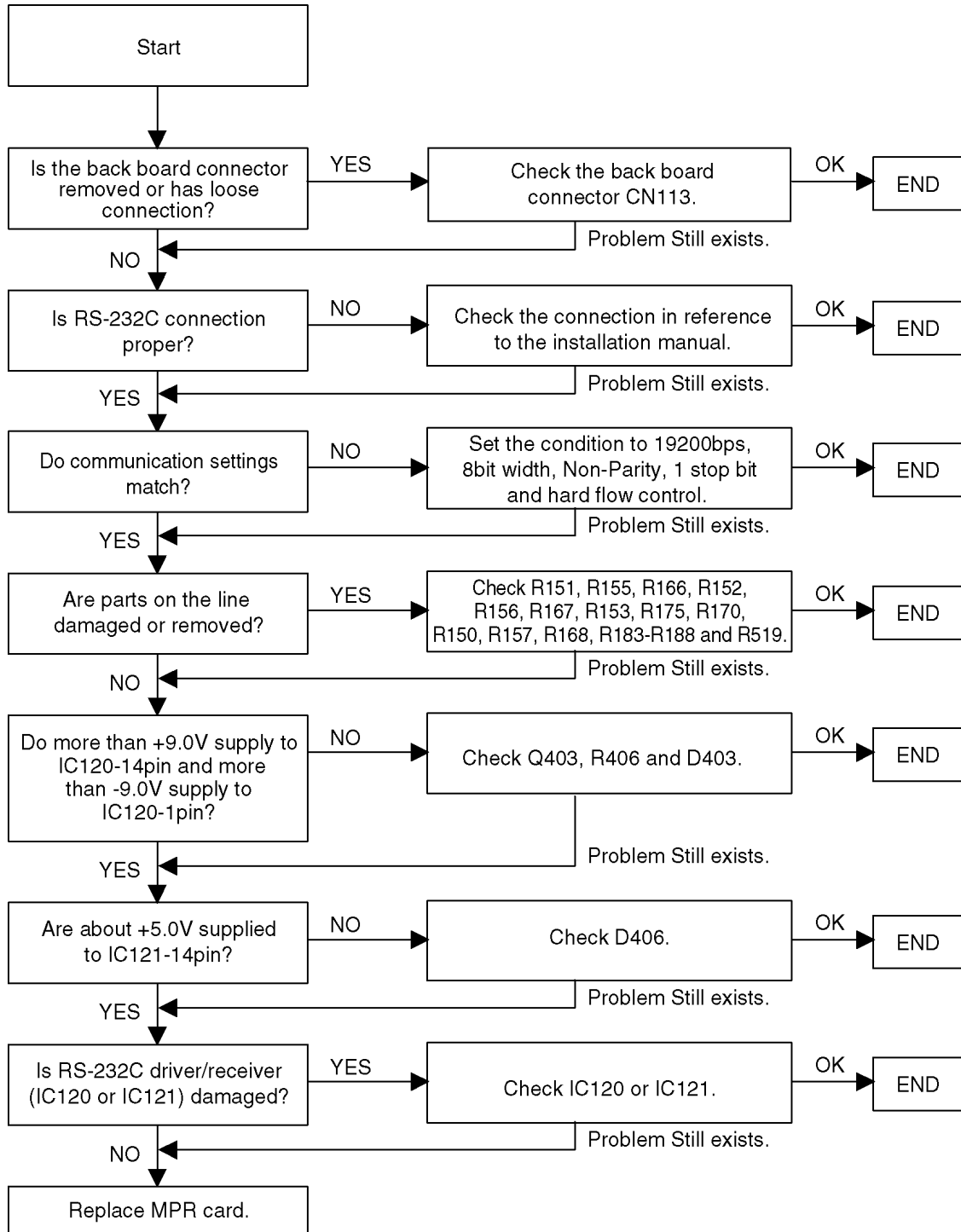

Connecting speed is slowly

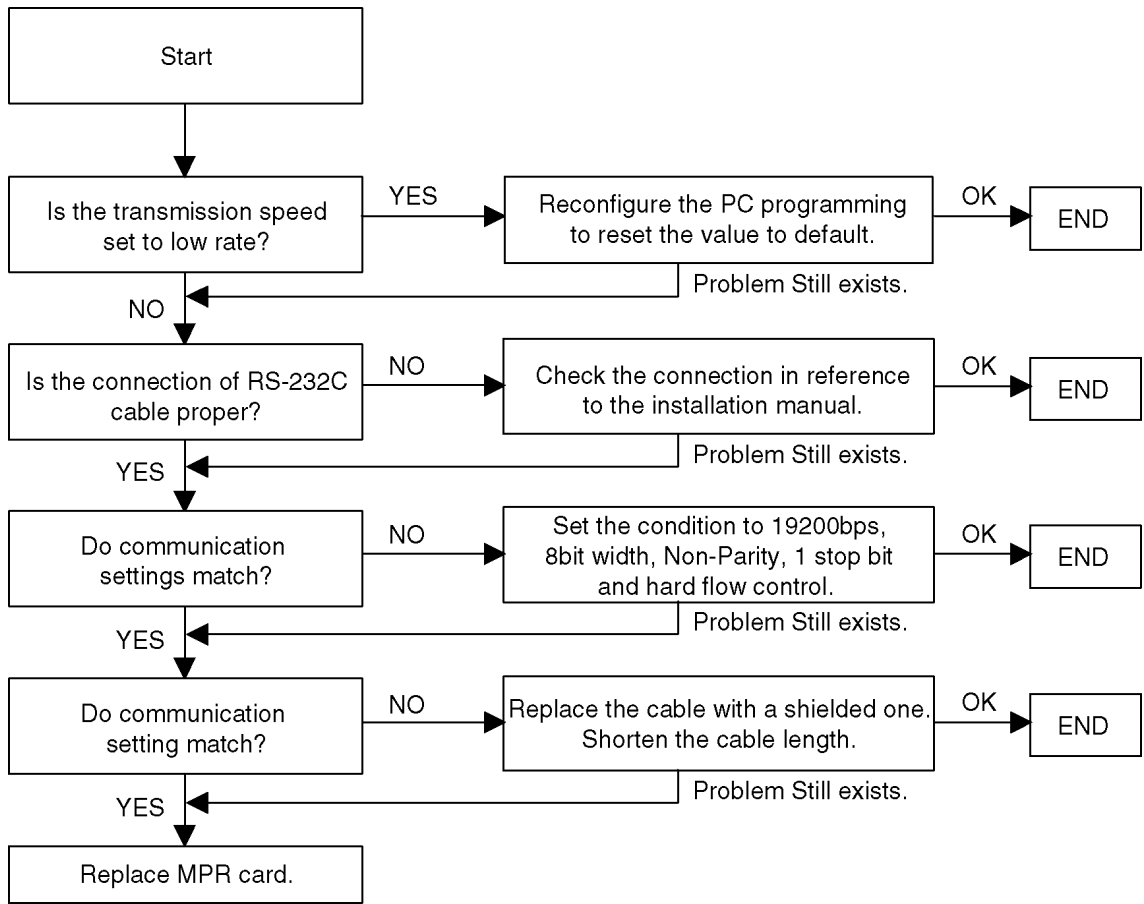

11.3.7. SD Card I/F

Unable to save the system data

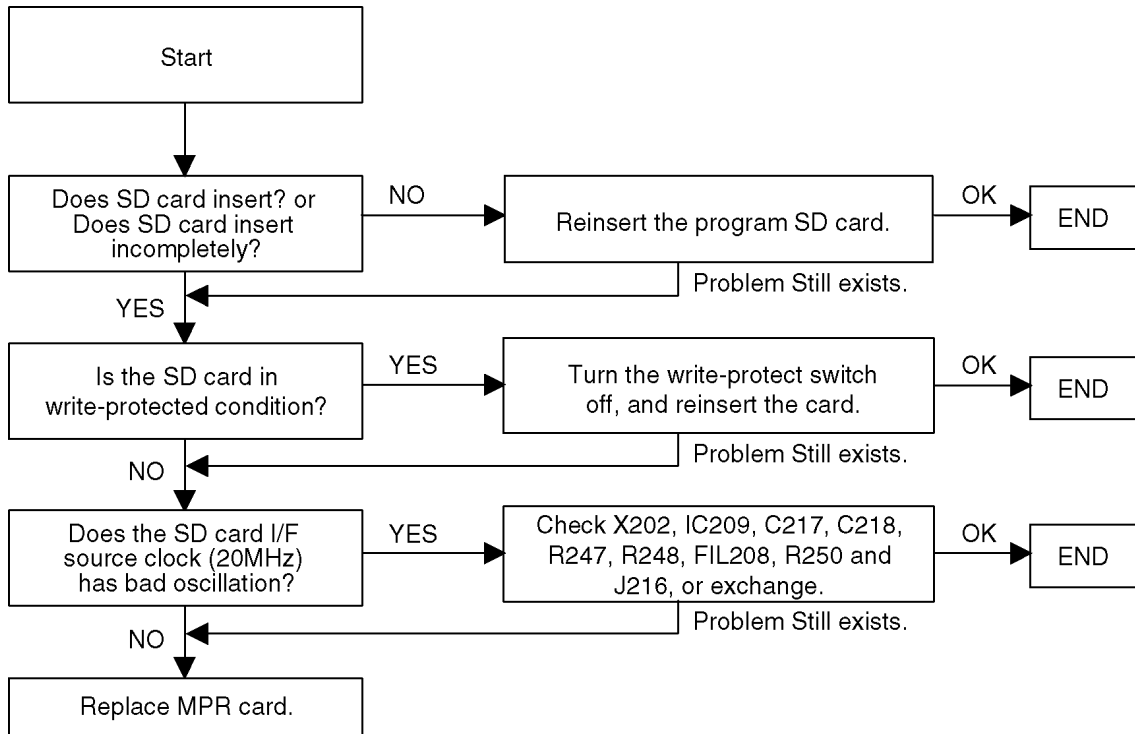

11.3.8. Other

The clock data is deleted (unset table)

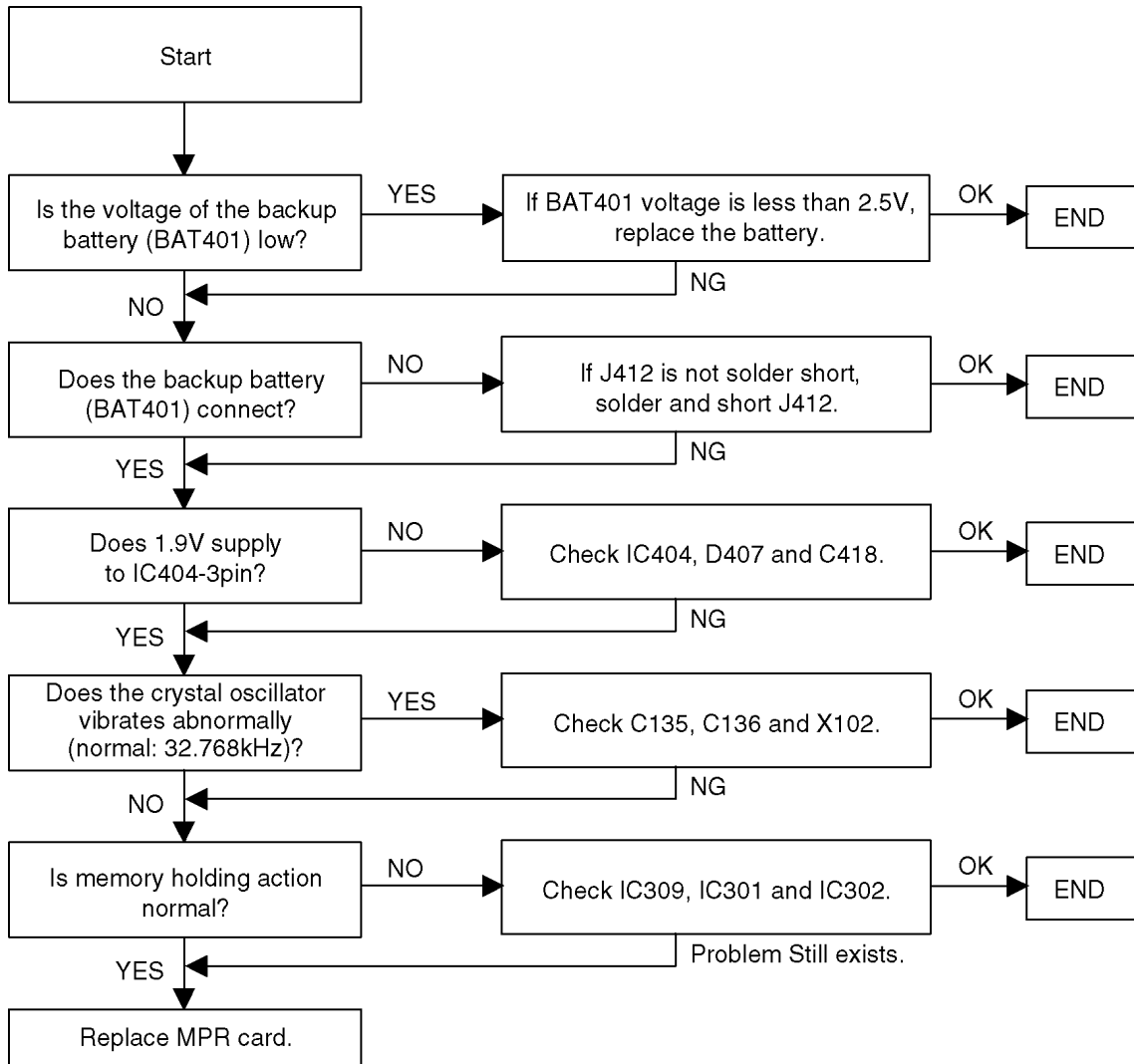

11.4. ERROR LOG

When a major system error occurs in the main unit (Hybrid IP-PBX), the ALARM indicator on the front of the cabinet turns on red, and the system logs the error information.

11.4.1. Error Log Display Format

Example: KX-TDA Maintenance Console

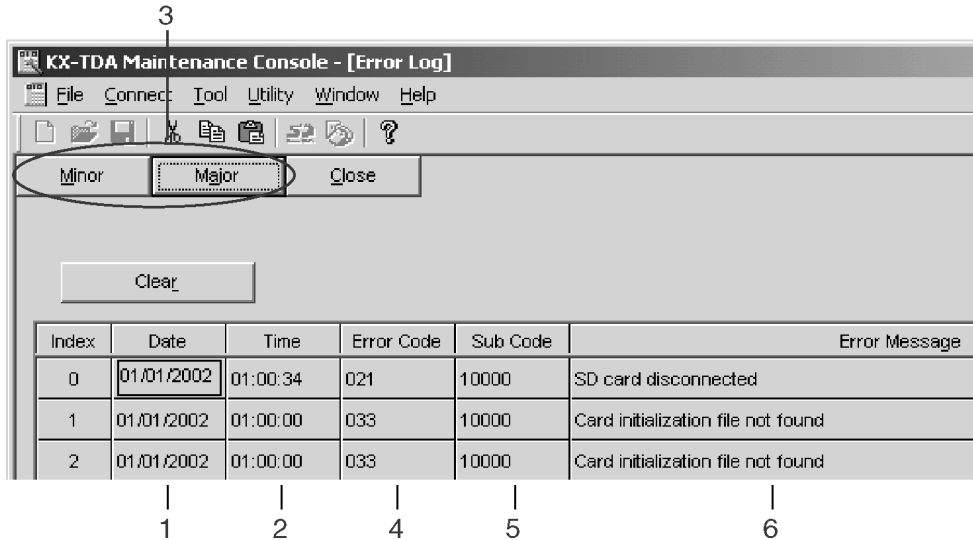

Example: Station Message Detail Recording (SMDR)

```

04/01/01 10:37AM MJ ALM #100 10000 WDT overflow
04/01/01 11:07AM MN ALM #100 10000 AC power down
04/01/01 03:55PM MN ALM #132 10501 Digital trunk RAI signal reception
    
```

1
2
3
4
5
6

		Description
Item	Description	
1	Date	Date of the error detection
2	Time	Time of the error detection
3	Level	Major Alarm (MJ ALM): Errors that affect the whole system operation, or result in system failure Minor Alarm (MN ALM): Errors that affect certain part of system operation
4	Error Code	Three-digit error code
5	Sub Code	Five-digit sub code (XYYZZ) X: Cabinet number (1 to 4) YY: Slot number KX-TDA100: 00 to 06 (00: MPR slot; 01 to 05: Free slot; 06: Option slot) KX-TDA200: 00 to 11 (00: MPR slot; 01 to 10: Free slot; 11: Option slot) ZZ: Physical port number (01 to 16) For OPB3 card, sub slot number + port number will be displayed. Sub slot 1: 11 to 14 Sub slot 2: 21 to 24 Sub slot 3: 31 to 34 Note: When there is no parameter for slot and physical port number, YY and ZZ will be displayed as "00". Example: Sub code for MPR card = 10000
6	Error Message	Error description (maximum 36 characters)

11.4.2. List of Errors and Solutions

The tables below list the errors and their solutions.

When an error whose error code is indicated with "*" occurs in the main unit (Hybrid IP-PBX), the ALARM indicator on the front of the cabinet turns on red, and the system logs the error information.

When the error conditions indicated by the error codes "021", "091", "230", and "510" are recovered, the ALARM indicator will turn off automatically, indicating successful troubleshooting. When other errors are logged, the ALARM indicator will turn off only when the log for major or minor errors is cleared from the KX-TDA Maintenance Console.

In other words, the ALARM indicator will turn off under the following conditions:

- **When the errors "021", "091", "230", and "510" are logged:** when the error conditions are recovered
- **When other errors are logged:** when the log for major or minor errors is cleared from the KX-TDA Maintenance Console

MPR Card Initial Self Diagnosis

Error Code	Error Message	PROBABLE CAUSE	SOLUTION
100	SRAM readwrite error	• MPR card malfunction	<ul style="list-style-type: none"> • See if the MPR card is installed properly • Press the Reset Button • Replace the MPR card (be sure to turn off the main unit (Hybrid IP-PBX) when replacing)
101	Flash write error		
102	Flash boot check error		
103	SDRAM readwrite error		
104	ASIC local bus register access error		
105	ASIC CT bus HW NG		
106	ASIC Local HW0 NG		
108	SD card not mounted	<ul style="list-style-type: none"> • SD Memory Card not installed • Defective data in SD Memory Card • MPR card malfunction 	<ul style="list-style-type: none"> • See if the SD Memory Card is installed properly • Replace the SD Memory Card • Replace the MPR card (be sure to turn off the main unit (Hybrid IP-PBX) when replacing)
109	ASIC HDLC error	• MPR card malfunction	<ul style="list-style-type: none"> • See if the MPR card is installed properly • Press the Reset Button • Replace the MPR card (be sure to turn off the main unit (Hybrid IP-PBX) when replacing)
110	ASIC DMAC error		

LPR (Optional Service Card with Local Processor) Initial Self Diagnosis

Error Code	Error Message	PROBABLE CAUSE	SOLUTION
210	ASIC local bus register access error	• Optional service card malfunction: DHLC, DLC, CSIF, T1, PRI, OPB3, CTI-LINK, E&M, IP-GW	<ul style="list-style-type: none"> • See if the corresponding optional service card is installed properly • Pull out and re-insert the corresponding optional service card • Press the Reset Button • Replace the corresponding optional service card
211	Speech path loop-back check error		
212	Echo cancellor access error		
213	CSINF frame sync. error		
214	DSP Boot check error		
215	Framer IC access error	• Optional service card malfunction: T1, PRI	<ul style="list-style-type: none"> • See if the corresponding optional service card is installed properly • Pull out and re-insert the corresponding optional service card • Press the Reset Button • Re-record the messages • Replace the corresponding optional service card
216	MSG card DSP error	• Optional service card malfunction: MSG, OPB3	
217	MSG card data error	<ul style="list-style-type: none"> • Optional service card malfunction: MSG, OPB3 • Erroneous recording of messages 	
218	LANC register access error	• Optional service card malfunction: CTI-LINK	<ul style="list-style-type: none"> • See if the corresponding optional service card is installed properly • Pull out and re-insert the corresponding optional service card • Press the Reset Button • Replace the corresponding optional service card

Error Code	Error Message	PROBABLE CAUSE	SOLUTION
219	PT I/F error	<ul style="list-style-type: none"> Optional service card malfunction: DHLC, DLC Software error due to external factors Breaking of telephone cord/interference of noise 	<ul style="list-style-type: none"> See if the corresponding optional service card is installed properly Pull out and re-insert the corresponding optional service card Press the Reset Button Check the wiring Replace the corresponding optional service card

System Start-up and On-line Operation

Error Code	Error Message	PROBABLE CAUSE	SOLUTION
000*	MPR WDT overflow	<ul style="list-style-type: none"> MPR card malfunction 	<ul style="list-style-type: none"> Press the Reset Button
001	SDRAM bit error	<ul style="list-style-type: none"> Erroneous processing of MPR card software Software error due to external factors 	<ul style="list-style-type: none"> Reprogram the main unit (Hybrid IP-PBX) Replace the MPR card (be sure to turn off the main unit (Hybrid IP-PBX) when replacing)
002	System Reset	<ul style="list-style-type: none"> Reset Button is pressed Power failure MPR card malfunction Erroneous processing of MPR card software Software error due to external factors 	<ul style="list-style-type: none"> Ignore if not frequent Press the Reset Button Reprogram the main unit (Hybrid IP-PBX) Replace the MPR card (be sure to turn off the main unit (Hybrid IP-PBX) when replacing)
010*	AC power down	<ul style="list-style-type: none"> Power supply system malfunction (e.g., power failure, power noise, trouble with UPS) Bad connection or breaking of AC cord Power supply circuit (PSU, back board) malfunction 	<ul style="list-style-type: none"> Check the power supply system See if the AC cord is connected properly Check the AC cord Replace the AC cord (be sure to turn off the main unit (Hybrid IP-PBX) when replacing) Replace the PSU (be sure to turn off the main unit (Hybrid IP-PBX) when replacing) Replace the back board (be sure to turn off the main unit (Hybrid IP-PBX) when replacing)
011*	DC power down	<ul style="list-style-type: none"> AC power down Power supply circuit (PSU, back board) malfunction Detection of over current (short circuit on optional service cards) 	<ul style="list-style-type: none"> Check the power supply system See if the AC cord is connected properly Check the AC cord Replace the AC cord (be sure to turn off the main unit (Hybrid IP-PBX) when replacing) Replace the PSU (be sure to turn off the main unit (Hybrid IP-PBX) when replacing) Replace the back board (be sure to turn off the main unit (Hybrid IP-PBX) when replacing) Remove the optional service cards and restart the main unit (Hybrid IP-PBX)
012*	MPR RAM battery low	<ul style="list-style-type: none"> Battery out MPR card malfunction 	<ul style="list-style-type: none"> Replace the MPR card (be sure to turn off the main unit (Hybrid IP-PBX) when replacing)
014*	FAN Alarm	<ul style="list-style-type: none"> PSU-L malfunction 	<ul style="list-style-type: none"> See if anything is jammed in the fan Replace the PSU (be sure to turn off the main unit (Hybrid IP-PBX) when replacing)
016	CS overload	<ul style="list-style-type: none"> Defective cable CS malfunction Optional service card malfunction: CSIF 	<ul style="list-style-type: none"> Check the cable diameter and length Replace the CS Replace the corresponding optional service card
018	CS superframe synchronization failure	<ul style="list-style-type: none"> Optional service card malfunction: CSIF 	<ul style="list-style-type: none"> Replace the corresponding optional service card
020*	SD file access error	<ul style="list-style-type: none"> SD Memory Card malfunction Bad connection of SD Memory Card MPR card malfunction 	<ul style="list-style-type: none"> Press the Reset Button Reprogram the main unit (Hybrid IP-PBX) Replace the SD Memory Card
021*	SD Memory Card disconnected	<ul style="list-style-type: none"> SD Memory Card not installed Bad connection of SD Memory Card SD Memory Card malfunction MPR card malfunction 	<ul style="list-style-type: none"> Replace the MPR card (be sure to turn off the main unit (Hybrid IP-PBX) when replacing)

Error Code	Error Message	PROBABLE CAUSE	SOLUTION
022*	Not enough free space on SD card	<ul style="list-style-type: none"> Not enough memory space available to save the system data, or to upload system files from the KX-TDA Maintenance Console 	<ul style="list-style-type: none"> Delete the files whose file names start with "\$" from SD Memory Card Delete the "Pxxx" files (old program files of optional service cards) from SD Memory Card. "xxx" indicates the card type (e.g., "PDHLC" for DHLC card) <p>Note: Do not delete the "PMPR" file; it is the program file of the MPR card.</p>
023*	System data file version error	<ul style="list-style-type: none"> Old system files on SD Memory Card Defective system files on SD Memory Card 	<ul style="list-style-type: none"> Restore the backup files Re-install the software
024*	System initialization file version error		
025*	Card initialization file version error		
026*	LCD file version error		
027*	System data file checksum error		
028*	System initialization file checksum error		
029*	Card initialization file checksum error		
030*	LCD file checksum error		
031*	System data file not found	<ul style="list-style-type: none"> SD Memory Card not installed Bad connection of SD Memory Card SD Memory Card malfunction MPR card malfunction 	<ul style="list-style-type: none"> Press the Reset Button Reprogram the main unit (Hybrid IP-PBX) Replace the SD Memory Card Replace the MPR card (be sure to turn off the main unit (Hybrid IP-PBX) when replacing)
032*	System initialization file not found		
033*	Card initialization file not found		
034*	LCD file not found		
035*	System data file access error		
036*	System initialization file access error		
037*	Card initialization file access error		
038*	LCD file access error		
040	Calendar IC failure	<ul style="list-style-type: none"> Erroneous processing of calendar IC of MPR card MPR card malfunction 	<ul style="list-style-type: none"> Reset the system clock Replace the MPR card (be sure to turn off the main unit (Hybrid IP-PBX) when replacing)
090	Card limitation over	<ul style="list-style-type: none"> Too many optional service cards installed 	<ul style="list-style-type: none"> Reduce the number of optional service cards
091	PT connection over	<ul style="list-style-type: none"> Too many PTs connected 	<ul style="list-style-type: none"> Reduce the number of PTs
200	LPR start up error (ROM NG)	<ul style="list-style-type: none"> Optional service card malfunction: DHLC, DLC, CSIF, T1, PRI, OPB3, CTI-LINK, E&M, IP-GW 	<ul style="list-style-type: none"> Pull out and re-insert the corresponding optional service card Press the Rest Button Replace the corresponding optional service card
201*	LPR start up error (RAM NG)		
202*	LPR start up error (No Program)		
203*	LPR start up error (Version NG)		
204*	LPR start up error (Version NG)		
205*	LPR start up error (No response)		
206	LPR start up error (Card type NG)		
207	LPR start up error (Check SUM NG)		
230*	Card disconnected	<ul style="list-style-type: none"> Optional service card not installed properly Optional service card malfunction Back board malfunction 	<ul style="list-style-type: none"> See if the corresponding optional service card is installed properly Pull out and re-insert the corresponding optional service card Press the Rest Button Replace the corresponding optional service card Replace the back board (be sure to turn off the main unit (Hybrid IP-PBX) when replacing)

Error Code	Error Message	PROBABLE CAUSE	SOLUTION
231	LPR alive check error	<ul style="list-style-type: none"> Optional service card malfunction: DHLC, DLC, CSIF, T1, PRI, OPB3, CTI-LINK, E&M, IP-GW Back board malfunction MPR card malfunction 	<ul style="list-style-type: none"> See if the corresponding optional service card is installed properly Pull out and re-insert the corresponding optional service card Press the Rest Button Replace the corresponding optional service card Replace the back board (be sure to turn off the main unit (Hybrid IP-PBX) when replacing) Replace the MPR card (be sure to turn off the main unit (Hybrid IP-PBX) when replacing)
232	MPR-LPR communication error		
233	LPR data check error		
234	DPLL clock failure		
235*	CS clock failure	<ul style="list-style-type: none"> Optional service card malfunction: CSIF 	<ul style="list-style-type: none"> Replace the corresponding optional service card
250	T1/E1 DSP failure	<ul style="list-style-type: none"> Optional service card malfunction: T1 	<ul style="list-style-type: none"> See if the corresponding optional service card is installed properly
251	MSG DSP failure	<ul style="list-style-type: none"> Optional service card malfunction: MSG 	<ul style="list-style-type: none"> Replace the corresponding optional service card
300*	Digital trunk out of synchronization	<ul style="list-style-type: none"> Network (digital CO line) malfunction Optional service card malfunction: PRI, T1, CTI-LINK Wrong A/B switch setting: PRI, T1 	<ul style="list-style-type: none"> Check the signals from the networkd is installed properly Check the cable See if the A/B switch is set to A on the corresponding optional service card See if the corresponding optional service card is installed properly Replace the corresponding optional service card
301*	Digital trunk RAI reception		
302*	Digital trunk AIS reception		
303*	Multiframe out of synchronization		
304*	Frame error		
305*	Data Link failure	<ul style="list-style-type: none"> Data link between the CS and CSIF card failed Data link between the network and PRI card failed 	<ul style="list-style-type: none"> Check the connection between the CS and CSIF card Check the connection between the network and PRI card
307	LAN No Carrier	<ul style="list-style-type: none"> IP-GW card not connected to the LAN 	<ul style="list-style-type: none"> Check the connection between the LAN and IP-GW card
310*	Port Link Failure	<ul style="list-style-type: none"> Voice Mail malfunction Ports defective on optional service card: DHLC, DLC 	<ul style="list-style-type: none"> Check the Voice Mail See if the corresponding optional service card is installed properly Replace the corresponding optional service card
390	Digital signal synchronization established	<ul style="list-style-type: none"> Synchronization of digital line established or restored 	<ul style="list-style-type: none"> This information is logged when synchronization of digital line is established, and does not indicate an error condition that needs to be solved
391	Data Link established	<ul style="list-style-type: none"> Connection with PC Phone/PC Console or Voice Mail (DTMF Integration) established or restored 	<ul style="list-style-type: none"> This information is logged when connection with PC Phone/PC Console or Voice Mail (DTMF Integration) is established, and does not indicate an error condition that needs to be solved. However, if this is logged frequently (with "305 Data Link failure"), check the connection as it may not be done properly.
392	Clock master card selected	<ul style="list-style-type: none"> Clock master card has been changed to the one indicated by the sub code 	<ul style="list-style-type: none"> Check if the proper card is selected as the new clock master card
510*	SMDR disconnect	<ul style="list-style-type: none"> RS-232C cable not connected Breaking of RS-232C cable Printer (terminal equipment) malfunction 	<ul style="list-style-type: none"> Check the RS-232C cable Check the terminal equipment

12 DIAGNOSIS

12.1. DIAGNOSIS FEATURES

Card Test and Pair Port Test is in Diagnosis Features.

12.1.1. Card Test

Card Test -SUMMARY

Description

Diagnose all kind of Cards.

Parallel of Diagnose item of Card Tests and every Cards

	DHLC	DLC	SLC8/L SLC8	MSLC/ SLC16	CS-INF	LCOT	T1	E1	BRI	PRI	OPB3	E&M	CTI- LINK
Local loop back diagnosis	X	X	X	X	X	X	X	X	X	X	X	X	
Card CT bus diagnosis	X	X	X	X	X	X	X	X	X	X	X	X	
DTMF receive test	X		X	X								X	
PT loop back diagnosis	X	X											
DSP DTMF generator/receiver diagnosis							X	X					
DSP DTMF receiver diagnosis							X	X					
Framer IC alarm signal detection diagnosis							X	X		X			
Framer IC error detection diagnosis							X	X		X			
CS-INF loop back diagnosis					X								
Super frame synchronization diagnosis					X								
Caller ID card loop back diagnosis						X							
Extension mode setting test									X				
CTI-LINK loop back diagnosis													X

12.1.1.1. Local Loop Back Diagnosis

Diagnose by transmission of the data from MPR to Card, and doing the Loop back test to return the data to MPR.

The point to do Loop back is different from the every cards, be able to do full diagnosis by Loop back test on the every points.

Local loop back diagnosis test

Primary circuit	Primary circuit loop back test
Framer IC ST path (Analog)	IC Analog I/F loop back test
Framer IC (Digital)	IC Digital I/F loop back test
ASIC CODEC (PITS)	PITS I/F test loop back
Local HW I/F point	Local HW I/F loop back test
Local TSW point	Local TSW loop back test

Local loop back diagnosis test of every Cards

	DHLC	DLC	SLC8/L SLC8	MSLC/ SLC16	CS-INF	LCOT	T1	E1	BRI	PRI	OPB3	E&M	CTI- LINK
Primary circuit							X	X		X			
Framer IC ST path (Analog)							X	X					
Framer IC (Digital)							X	X	X	X			
ASIC CODEC (PITS)													
Local HW I/F point			X	X		X	X	X	X	X	X	X	
Local TSW point	X	X	X	X	X	X	X	X	X	X	X	X	

Diagnosis result of every test points

OK	loop back diagnosis OK
NG	loop back diagnosis NG

12.1.1.2. Card CT Bus Diagnosis

Diagnose CT bus by Loop back test to use CT bus

	DHLC	DLC	SLC8/L SLC8	MSLC/ SLC16	CS-INF	LCOT	T1	E1	BRI	PRI	OPB3	E&M	CTI- LINK
Object of Card	X	X	X	X	X	X	X	X	X	X	X	X	X

Diagnosis result

OK	Card CT bus diagnosis OK
NG	Card CT bus diagnosis NG

12.1.1.3. DTMF Receive Test

Diagnosis DTMF receiver

	DHLC	DLC	SLC8/L SLC8	MSLC/ SLC16	CS-INF	LCOT	T1	E1	BRI	PRI	OPB3	E&M	CTI- LINK
Object of Card	X		X	X								X	

Diagnosis result

OK	DTMF receive test OK
NG	DTMF receive test NG

12.1.1.4. PT Loop Back Diagnosis

Diagnosis PT by Loop back test

	DHLC	DLC	SLC8/L SLC8	MSLC/ SLC16	CS-INF	LCOT	T1	E1	BRI	PRI	OPB3	E&M	CTI- LINK
Object of Card	X	X											

PT loop back diagnosis test channel

Cch port xx	C channel Port No.xx test
Dch port xx	D channel Port No. xx test
Bch port xx	B channel Port No. xx test

PT loop back diagnosis test

Primary circuit	Primary circuit loopback test
ASIC (PT I/F)	PT I/F loopback test

Diagnosis result

OK	PT loop back diagnosis OK
NG	PT loop back diagnosis NG

12.1.1.5. DSP DTMF Generator / Receiver Diagnosis

Diagnosis DTMF generator/receiver of DSP in the Card

	DHLC	DLC	SLC8/L SLC8	MSLC/ SLC16	CS-INF	LCOT	T1	E1	BRI	PRI	OPB3	E&M	CTI- LINK
Object of Card							X	X					

diagnosis point

Time slot	Time slot test
Primary circuit	Primary circuit loop back test
DSP ST loop back	DSP ST point loop back test
DSP digital loop back	DSP digital point loop back test

Diagnosis result

OK	DSP DTMF generator/receiver diagnosis OK
NG	DSP DTMF generator/receiver diagnosis NG

12.1.1.6. DSP DTMF Receiver Diagnosis

Diagnose DTMF receiver of DSP in the Card to use DTMF generator of DSP

	DHLC	DLC	SLC8/L SLC8	MSLC/ SLC16	CS-INF	LCOT	T1	E1	BRI	PRI	OPB3	E&M	CTI- LINK
Object of Card							X	X					

Diagnosis point

Time slot	Time slot test
Primary circuit	Primary circuit loop back test
DSP ST loop back	DSP ST point loop back test
DSP digital loop back	DSP digital point loop back test

Diagnosis result

OK	DSP DTMF generator/receiver diagnosis OK
NG	DSP DTMF generator/receiver diagnosis NG

12.1.1.7. Framer IC Alarm Signal Detection Diagnosis

Diagnose the feature to detect the alarm signal of Framer IC is normal action.

	DHLC	DLC	SLC8/L SLC8	MSLC/ SLC16	CS-INF	LCOT	T1	E1	BRI	PRI	OPB3	E&M	CTI- LINK
Object of Card							X	X		X			

Diagnosis point

RAI	Yellow alarm signal detection test
AIS	Blue alarm signal detection test
Primary circuit	Primary circuit alarm signal detection test

Diagnosis result

OK	Framer IC alarm signal detection diagnosis OK
NG	Framer IC alarm signal detection diagnosis NG

12.1.1.8. Framer IC Error Detection Diagnosis

Diagnose the feature to detect the alarm signal of Framer IC is normal action.

	DHLC	DLC	SLC8/L SLC8	MSLC/ SLC16	CS-INF	LCOT	T1	E1	BRI	PRI	OPB3	E&M	CTI- LINK
Object of Card							X	X		X			

Diagnosis point

Bipolar violation error	Bipolar violation error detection test
CRC error	CRC error detection test
Framing error	Framing error detection test
Primary circuit	Primary circuit error detection test

Diagnosis result

OK	DSP DTMF generator/receiver diagnosis OK
NG	DSP DTMF generator/receiver diagnosis NG

12.1.1.9. CS-INF Loop Back Diagnosis

Diagnose by Loop back test to CS-INF

	DHLC	DLC	SLC8/L SLC8	MSLC/ SLC16	CS-INF	LCOT	T1	E1	BRI	PRI	OPB3	E&M	CTI- LINK
Object of Card					X								

CS-INF loop back diagnosis test channel

Dch port xx	D channel Port No. xx test
Bch port xx	B channel Port No. xx test

Diagnosis point

DNIC analog	DNIC analog loop back test
DNIC digital	DNIC digital loop back test

Diagnosis result

OK	CS-INF loop back diagnosis OK
NG	CS-INF loop back diagnosis NG

12.1.1.10. Super Frame Synchronization Diagnosis

Diagnose Super frame synchronization feature of CS-INF

	DHLC	DLC	SLC8/L SLC8	MSLC/ SLC16	CS-INF	LCOT	T1	E1	BRI	PRI	OPB3	E&M	CTI- LINK
Object of Card					X								

Diagnosis point

DECT	DECT super frame synchronization test
SS	SS super frame synchronization test

Diagnosis result

OK	Super frame synchronization diagnosis OK
NG	Super frame synchronization diagnosis NG

12.1.1.11. Caller ID Card Loop Back Diagnosis

Diagnose by Loop back test to Caller ID card (Optional Card of LCOT)

	DHLC	DLC	SLC8/L SLC8	MSLC/ SLC16	CS-INF	LCOT	T1	E1	BRI	PRI	OPB3	E&M	CTI- LINK
Object of Card						X							

Diagnosis result

OK	Caller ID card loop back diagnosis OK
NG	Caller ID card loop back diagnosis NG

12.1.1.12. Extension Mode Setting Test

Diagnose the normal change from outside line mode to inside line mode

	DHLC	DLC	SLC8/L SLC8	MSLC/ SLC16	CS-INF	LCOT	T1	E1	BRI	PRI	OPB3	E&M	CTI- LINK
Object of Card									X				

Diagnosis result

OK	Extension mode setting test OK
NG	Extension mode setting test NG

12.1.1.13. CTI-LINK Loop Back Diagnosis

Diagnose by Loop back test to CS-INF

	DHLC	DLC	SLC8/L SLC8	MSLC/ SLC16	CS-INF	LCOT	T1	E1	BRI	PRI	OPB3	E&M	CTI- LINK
Object of Card													X

Diagnosis result

OK	CTI-LINK loop back diagnosis OK
NG	CTI-LINK loop back diagnosis NG

12.1.2. Pair Port Test

Pair Port Test -SUMMARY

Description

Diagnosis Pair Port Test to pair up inside line and outside line

	DHLC	DLC	SLC8/L SLC8	MSLC/ SLC16	CS-INF	LCOT	T1	E1	BRI	PRI	OPB3	E&M	CTI- LINK
Object of Card	X		X	X		X							

Diagnosis result

OK	Pair Port Test OK
NG	Pair Port Test NG

Detail Diagnosis result

Line current OFF (Ext->CO)	There is no local current from inside line to outside line
Line current ON (Ext->CO)	There is local current from inside line to outside line
Off hook detection (CO->Ext)	Off-hook detection from outside line to inside line
DTMF detection (CO->Ext)	DTMF transmission/detection from outside line to inside line
DP detection (CO->Ext)	SP transmission/detection from outside line to inside line
BELL detection (Ext->CO)	Bell transmission/detection from inside line to outside line
Speech path (Ext->CO)	Call lime from inside line to outside line
Speech path (CO->Ext)	Call lime from outside line to inside line

12.2. DIAGNOSIS TEST

1. Click [Diagnosis] of [Utility].

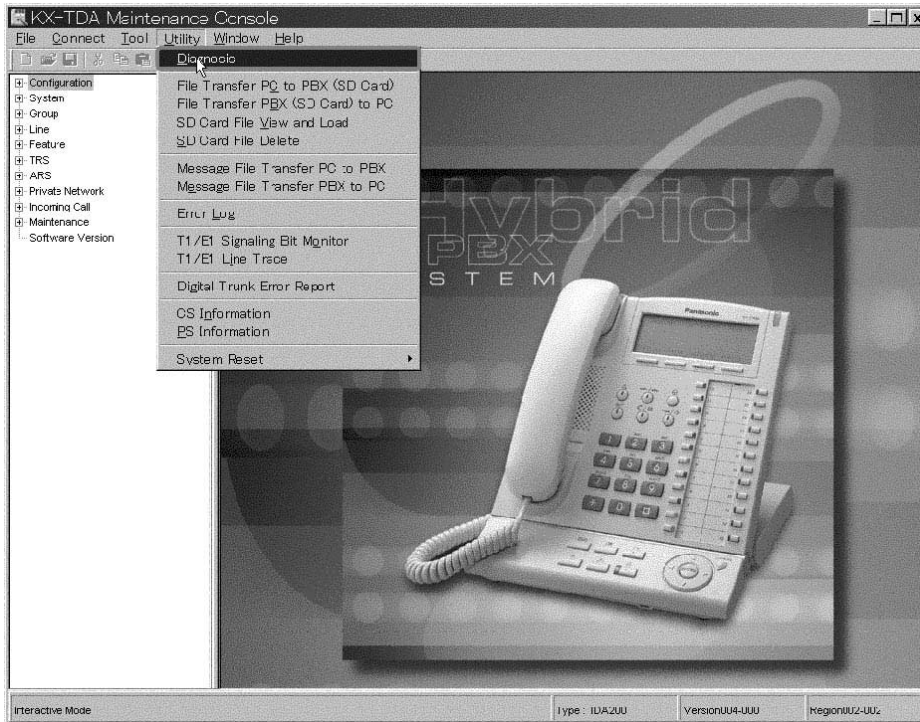

2. Pair Port Test operation Select card for Test.

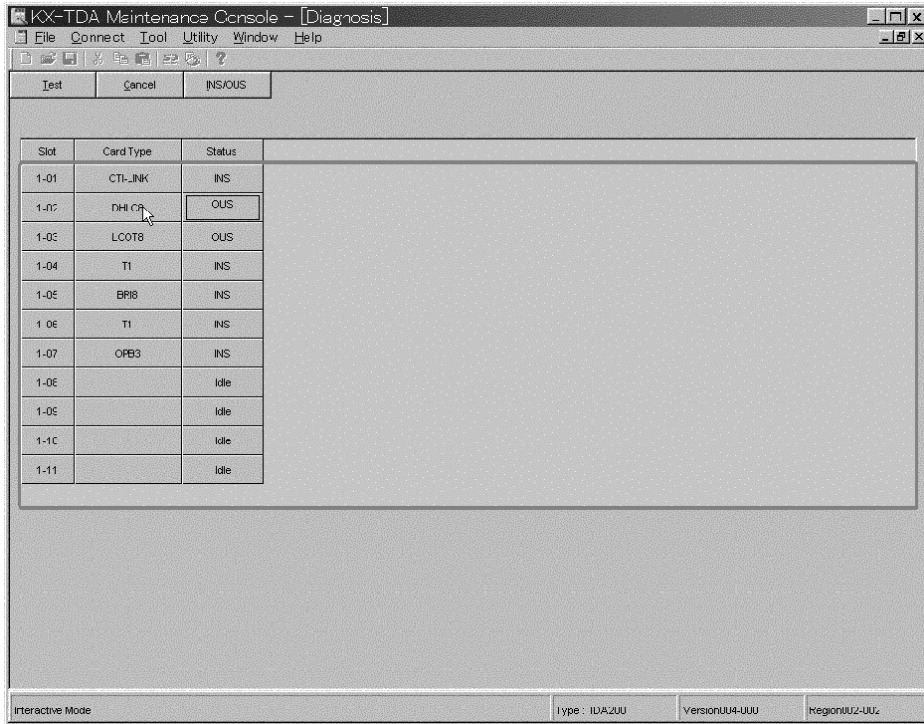

3. Click [Pair Port Test].

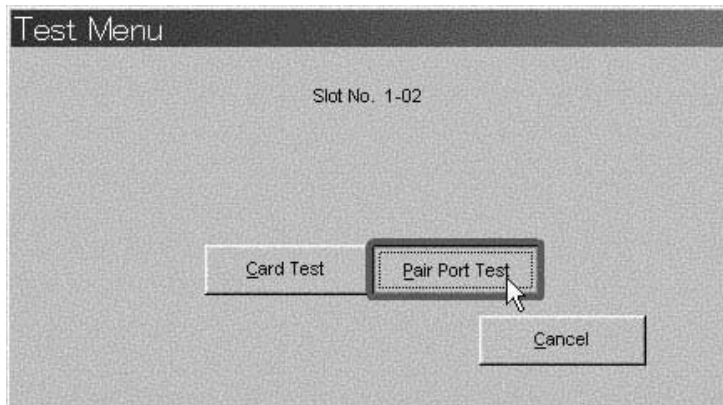

4. Click [OK].

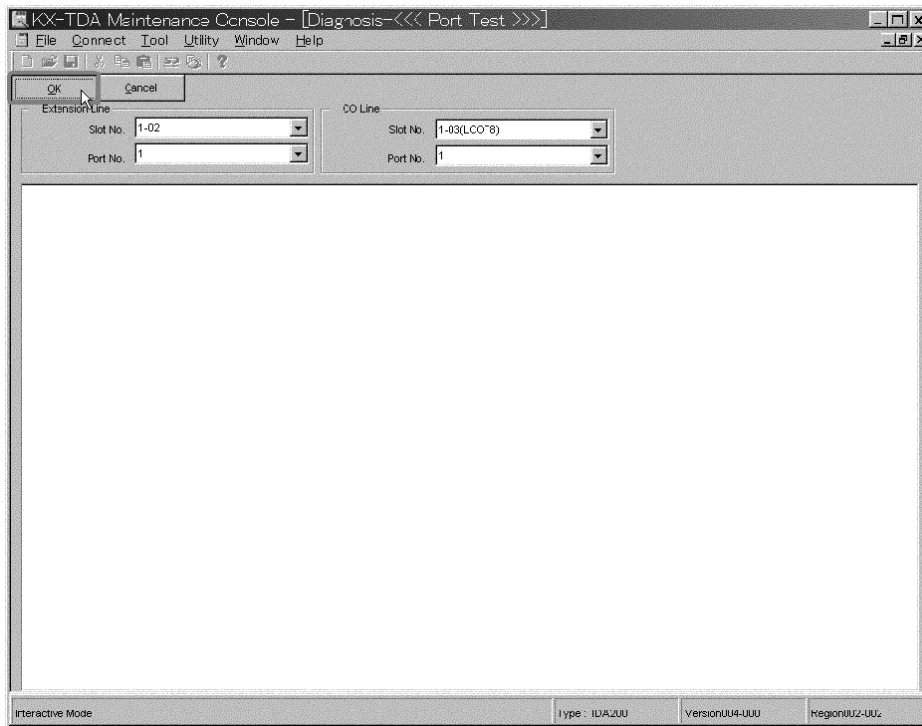

5. Click [Cancel].

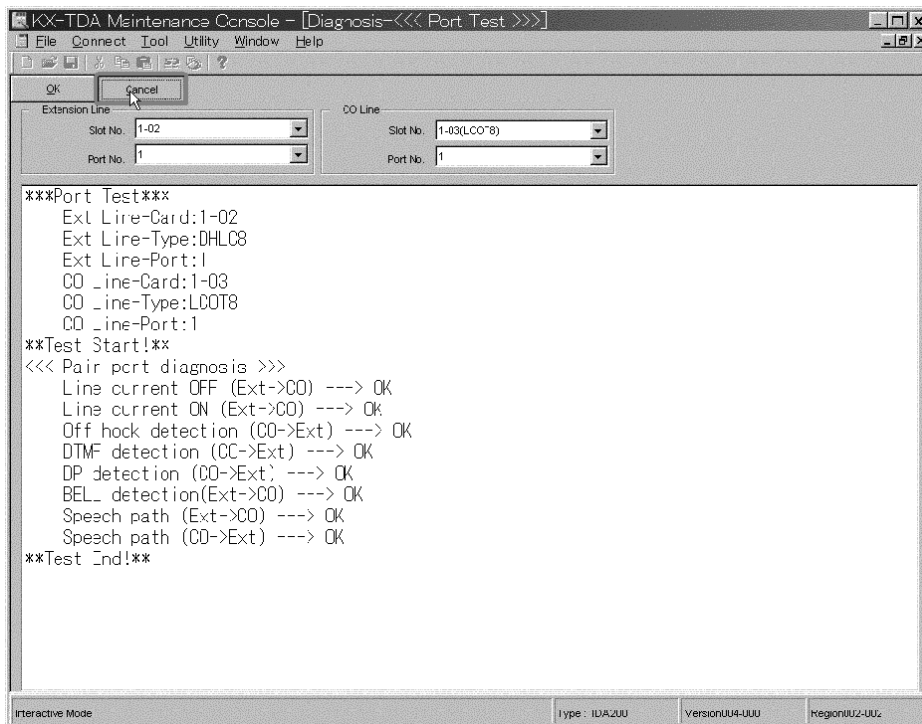

6. Card Test operation Select card for Test.

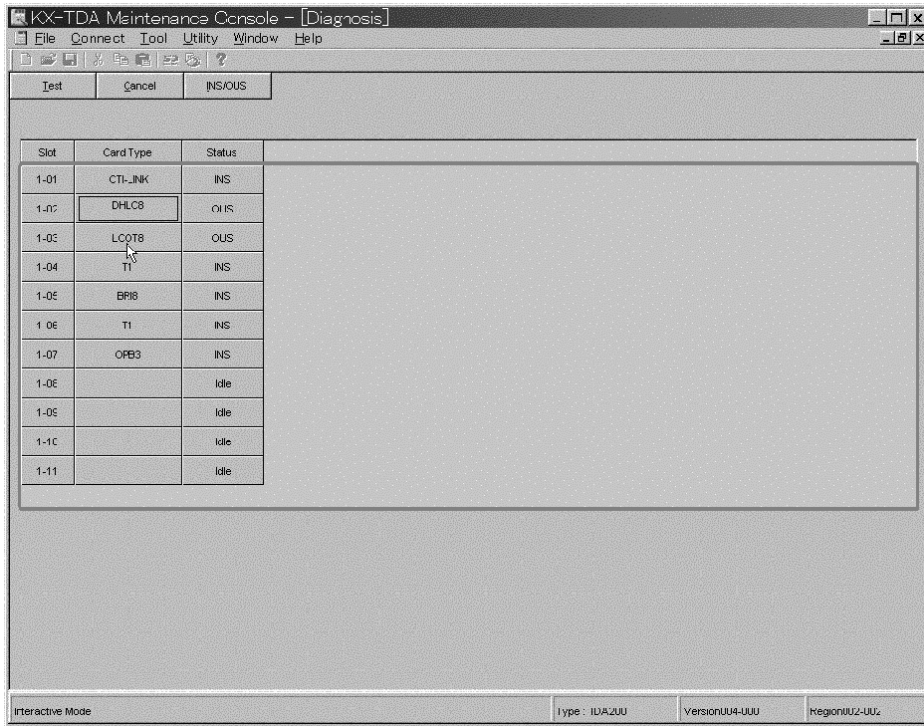

7. Click [Card Test].

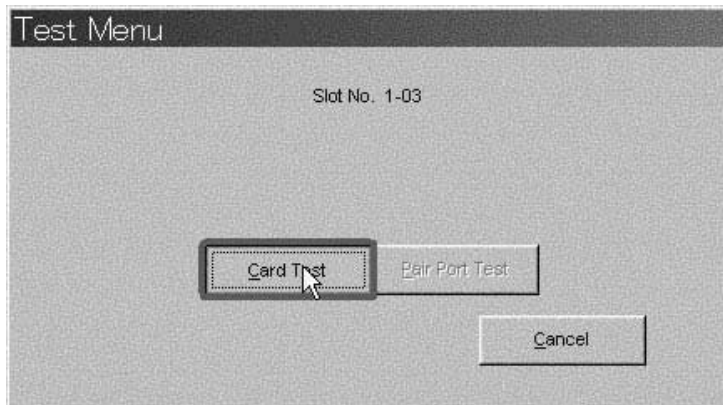

8. Click [OK].

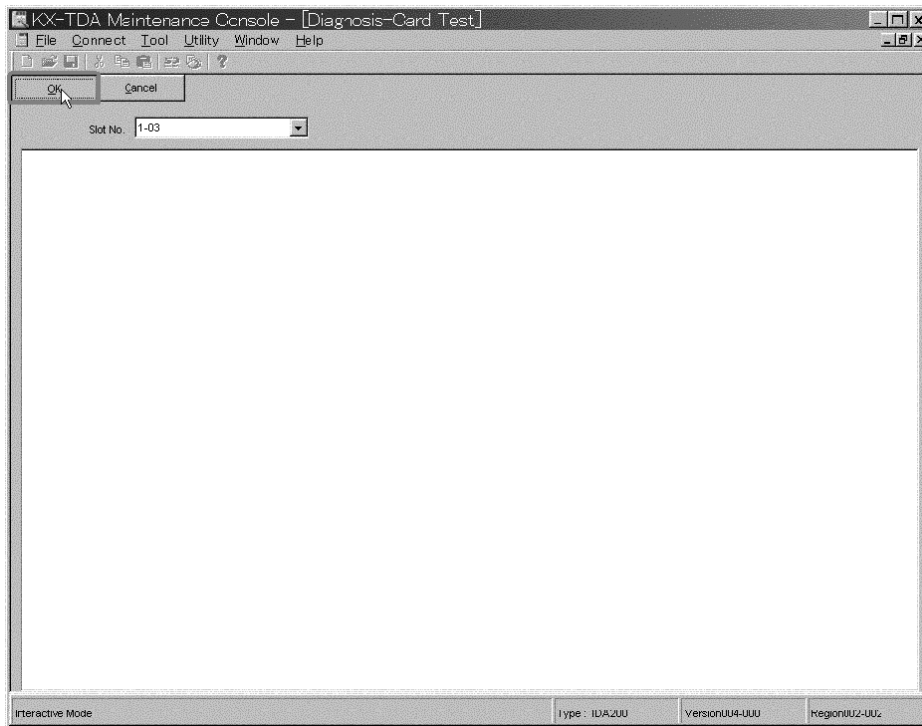

9. Click [Cancel].

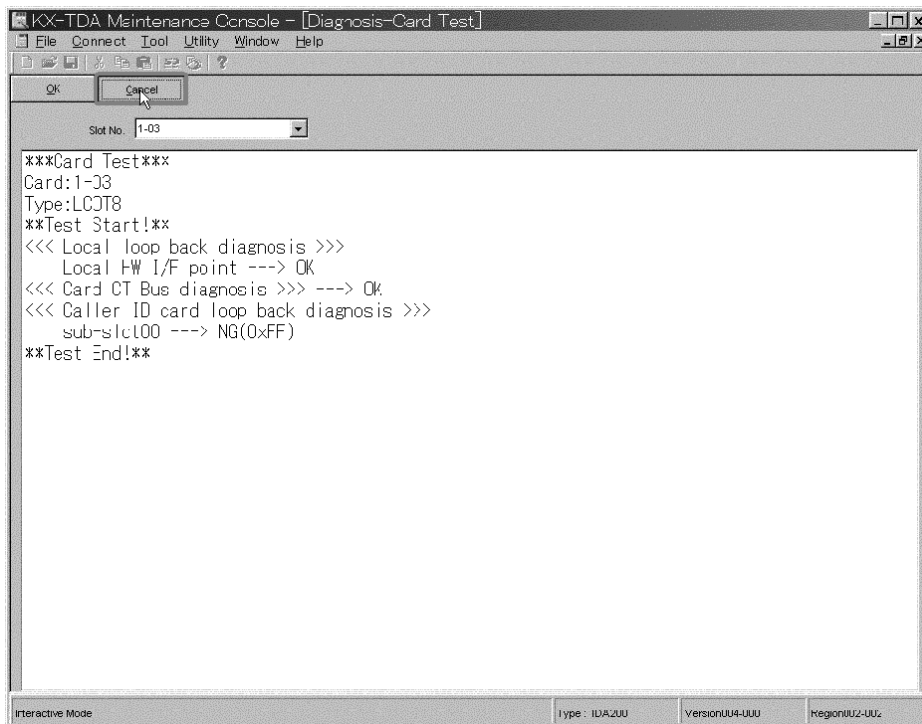

13 IC DATA

13.1.

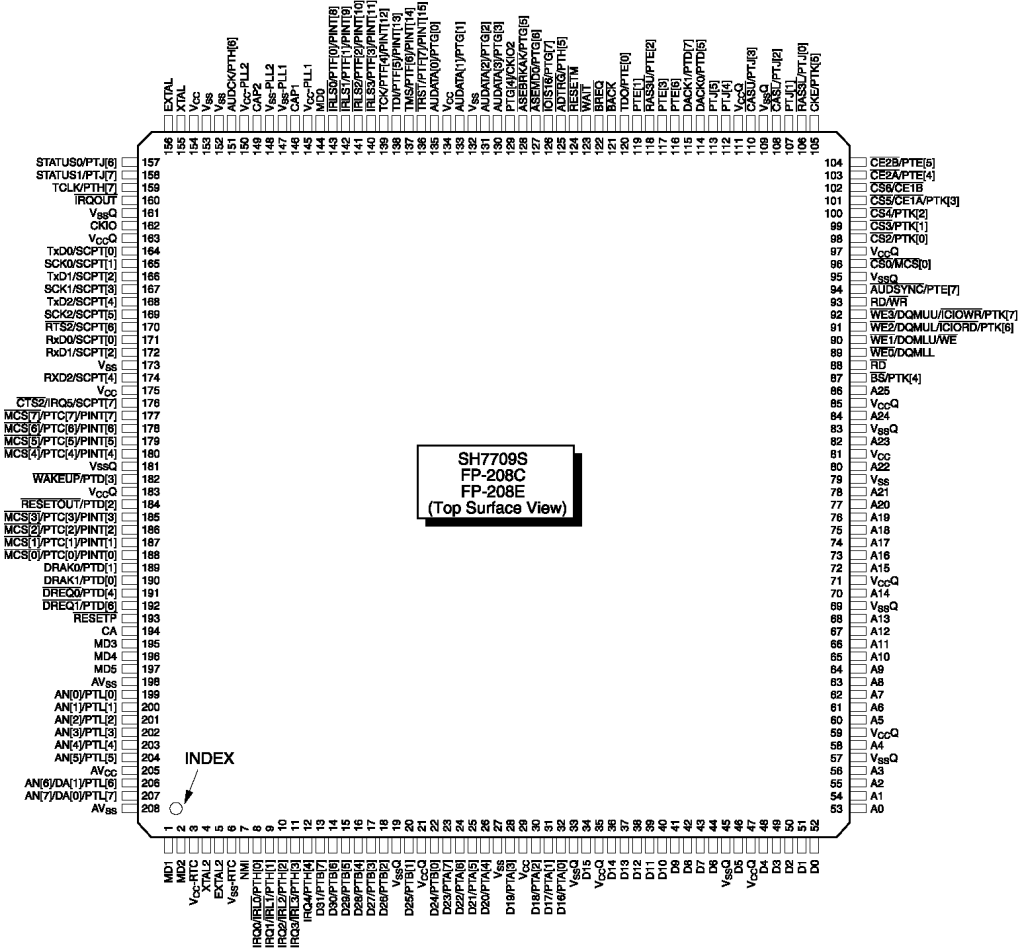

Pin No.	Pin Name	I/O	Description
1	MD1	I	Clock mode setting
2	MD2	I	Clock mode setting
3	Vcc-TRC*1	-	Power for RTC
4	XTAL2	O	Crystal oscillator terminal for built-in RTC
5	EXTAL2	I	Crystal oscillator terminal for built-in RTC (*6)
6	Vcc-TRC*1	-	Power for RTC
7	NMI	I	Nonmaskable interrupt request
8	IRQ0/IRL0/PTH[0]	I	External interrupt request/input port H
9	IRQ1/IRL1/PTH[1]	I	External interrupt request/input port H
10	IRQ2/IRL2/PTH[2]	I	External interrupt request/input port H
11	IRQ3/IRL3/PTH[3]	I	External interrupt request/input port H
12	IRQ4/PTH[4]	I	External interrupt request/input port H
13	D31/PTB[7]	I/O	Data bus/I/O port B
14	D30/PTB[6]	I/O	Data bus/I/O port B
15	D29/PTB[5]	I/O	Data bus/I/O port B
16	D28/PTB[4]	I/O	Data bus/I/O port B
17	D27/PTB[3]	I/O	Data bus/I/O port B
18	D26/PTB[2]	I/O	Data bus/I/O port B
19	VssQ	-	Power for I/O (0V)
20	D25/PTB[1]	I/O	Data bus/I/O port B
21	VssQ	-	Power for I/O (3.3V)
22	D24/PTB[0]	I/O	Data bus/I/O port B
23	D23/PTA[7]	I/O	Data bus/I/O port A
24	D22/PTA[6]	I/O	Data bus/I/O port A
25	D21/PTA[5]	I/O	Data bus/I/O port A
26	D20/PTA[4]	I/O	Data bus/I/O port A
27	Vss	-	Power supply (0V)
-	Vss	-	Power supply (0V)
28	D19/PTA[3]	I/O	Data bus/I/O port A

Pin No.	Pin Name	I/O	Description
29	Vcc	-	Power supply (*3)
-	Vcc	-	Power supply (*3)
30	D18/PTA[2]	I/O	Data bus/I/O port A
31	D17/PTA[1]	I/O	Data bus/I/O port A
32	D16/PTA[0]	I/O	Data bus/I/O port A
33	VssQ	-	Power for I/O (0V)
34	D15	I/O	Data bus
35	VccQ	-	Power for I/O (3.3V)
36	D14	I/O	Data bus
37	D13	I/O	Data bus
38	D12	I/O	Data bus
39	D11	I/O	Data bus
40	D10	I/O	Data bus
41	D9	I/O	Data bus
42	D8	I/O	Data bus
43	D7	I/O	Data bus
44	D6	I/O	Data bus
45	VssQ	-	Power for I/O (0V)
46	D5	I/O	Data bus
47	VccQ	-	Power for I/O (3.3V)
48	D4	I/O	Data bus
49	D3	I/O	Data bus
50	D2	I/O	Data bus
51	D1	I/O	Data bus
52	D0	I/O	Data bus
53	A0	O	Address bus
54	A1	O	Address bus
55	A2	O	Address bus
56	A3	O	Address bus
57	VssQ	-	Power for I/O (0V)
58	A4	O	Address bus
59	VssQ	-	Power for I/O (3.3V)
60	A5	O	Address bus
61	A6	O	Address bus
62	A7	O	Address bus
63	A8	O	Address bus
64	A9	O	Address bus
65	A10	O	Address bus
66	A11	O	Address bus
67	A12	O	Address bus
68	A13	O	Address bus
69	VssQ	-	Power for I/O (0V)
70	A14	O	Address bus
71	VccQ	-	Power for I/O (3.3V)
72	A15	O	Address bus
73	A16	O	Address bus
74	A17	O	Address bus
75	A18	O	Address bus
76	A19	O	Address bus
77	A20	O	Address bus
78	A21	O	Address bus
79	Vss	-	Power supply (0V)
-	Vss	O	Power supply (0V)
80	A22	O	Address bus
81	Vss	-	Power supply (*3)
-	Vss	-	Power supply (*3)
82	A23	O	Address bus
83	VssQ	-	Power for I/O (0V)
84	A24	O	Address bus
85	VssQ	-	Power for I/O (3.3V)
86	A25	O	Address bus
87	BS/PTK[4]	O/I/O	Bus cycle start signal/I/O port K
88	RD	O	Read stroke
89	WE0/DQMLL	O	D7-D0 select signal/DOM (SDRAM)
90	WE1/DQMLU/WE	O	D15-D8 select signal/DOM (SDRAM)
91	WE2/DQMUL/ICIORD/ PTK[6]	O/I/O	D23-D16 select signal/DOM (SDRAM) /PCMCIA I/O read/I/O port K

Pin No.	Pin Name	I/O	Description
92	WE3/DQM00/ICLOW R/PTK[7]	O/I/O	D31-D24 select signal/DOM (SDRAM) /PCMCIA I/O write/I/O port K
93	RD/WR	O	Read/Write
94	AUDSYNCPTE[7]	O/I/O	AUD synchronization/I/O port E
95	VssQ	-	Power for I/O (0V)
96	CS0/MCS[0]	O	Chip select 0/mask ROM chip select 0
97	VccQ	-	Power for I/O (3.3V)
98	CS2/PTK[0]	O/I/O	Chip select 2/I/O port K
99	CS3/PTK[1]	O/I/O	Chip select 3/I/O port K
100	CS4/PTK[2]	O/I/O	Chip select 4/I/O port K
101	CS5/PTK[3]	O/I/O	Chip select 5/CE1 (Area 5PCMCIA)/I/O port K
102	CS6/CE1B	O	Chip select 6/CE1 (Area 6PCMCIA)
103	CE2A/PTE[4]	O/I/O	CE2(Area 5PCMCIA)/ I/O port K
104	CE2B/PTE[5]	O/I/O	CE2(Area 6PCMCIA)/ I/O port K
105	CKE/PTK[5]	O/I/O	CK Enable (SDRAM) / I/O port K
106	RAS3L/PTJ[0]	O/I/O	RAS for low 32M/64M bytes address (SDRAM) /I/O port J
107	PTJ[1]	I/O	I/O port J
108	CASL/PTJ[2]	O/I/O	RAS for low 32M/64M bytes address (SDRAM) /I/O port J
109	VssQ	-	Power for I/O (0V)
110	CASU/PTJ[3]	O/I/O	RAS for low 32M bytes address (SDRAM) /I/O port J
111	VssQ	-	Power for I/O (3.3V)
112	PTJ[4]	I/O	I/O port J
113	PTJ[5]	I/O	I/O port J
114	DACK0/PTD[5]	O/I/O	DMA acknowledge0/I/O port D
115	DACK1/PTD[7]	O/I/O	DMA acknowledge1/I/O port D
116	PTE[6]	I/O	I/O port E
117	PTE[3]	I/O	I/O port E
118	RAS3U/PTE[2]	O/I/O	RAS for low 32M bytes address (SDRAM) / I/O port E
119	PTE[1]	I/O	I/O port E
120	TDO/PTE[0]	O/I/O	Test data output/I/O port E
121	BACK	O	Bus acknowledge
122	BREQ	I	Bus request
123	WAIT	I	Hardware wait request
124	RESETM	I	Manual reset request
125	ADTRG/PTH[2]	I	Analog trigger/input port H
126	IOIS16/PTG[7]	I	IOIS168 (PCMCIA) / I/O port G
127	ASEMD0/PTG[6]	I	ASE mode:4/I/O port G
128	ASEBRKAK/PTG[5]	I/O	ASE break acknowledge/I/O port G
129	PTG[4]/CKIO2	I/O	Input port G/clock output
130	AUDATA[3]/PTG[3]	I/O/I	AUD data/input port G
131	AUDATA[2]/PTG[2]	I/O/I	AUD data/input port G
132	Vss	-	Power supply (0V)
-	Vss	-	Power supply (0V)
133	AUDATA[1]/PTG[1]	I/O/I	AUD data/input port G
134	Vcc	-	Power supply (*3)
-	Vcc	-	Power supply (*3)
135	AUDATA[0]/PTG[0]	I/O/I	AUD data/input port G
136	TRST/PTF[7]/PINT[15]	I	Test reset/input port F/port interruption
137	TMS/PTF[6]/PINT[14]	I	Test mode switch/input port F/port interruption
138	TDI/PTF[5]/PINT[13]	I	Test mode switch/input port F/port interruption
139	TCK/PTF[4]/PINT[12]	I	Test clock/input port F/port interruption
140	IRS3/PTF[3]/PINT[11]	I	External interrupt request/input port F/port interruption
141	IRS2/PTF[2]/PINT[10]	I	External interrupt request/input port F/port interruption
142	IRS1/PTF[1]/PINT[9]	I	External interrupt request/input port F/port interruption
143	IRS0/PTF[0]/PINT[8]	I	External interrupt request/input port F/port interruption
144	MD0	I	Clock mode setting
145	Vcc-PLL1*2	-	Power for PLL1 (*3)
146	CAP1	-	External capacity terminal for PLL1
147	Vss-PLL1*2	-	Power for PLL1 (0V)
148	Vss-PLL2*2	-	Power for PLL1 (1V)
149	CAP2	-	External capacity terminal for PLL2
150	Vcc-PLL2*2	-	Power for PLL2 (*3)
151	AUDCK/PTH[6]	I	AUD clock/input port H
152	Vss	-	Power supply (0V)
153	Vss	-	Power supply (0V)
-	Vss	-	Power supply (0V)
154	Vcc	-	Power supply (*3)

Pin No.	Pin Name	I/O	Description
-	Vcc	-	Power supply (*3)
155	XTAL	O	Clock oscillator terminal
156	EXTAL	I	External clock/crystal oscillator terminal
157	STATUS0/PTJ[6]	O/I/O	Processor status
158	STATUS0/PTJ[7]	O/I/O	Processor status
159	TCLK/PTH[7]	I/O	Clock I/O for TMU or RTC/I/O port J
160	IRQOUT	O	Interrupt request notification
161	VssQ	-	Power for I/O (0V)
162	CKIO	I/O	System clock I/O
163	VccQ	-	Power for I/O (3.3V)
164	TxD0/SCPT[0]	O	Transmission data 0/output port for SCI
165	SCK0/SCPT[1]	I/O	Serial clock 0/output port for SCI
166	TxD1/SCPT[2]	O	Transmission data 1/output port for SCI
167	SCK1/SCPT[3]	I/O	Serial clock 1/output port for SCI
168	TxD2/SCPT[4]	O	Transmission data 2/output port for SCI
169	SCK2/SCPT[5]	I/O	Serial clock 2/output port for SCI
170	RTS0/SCPT[6]	O/I/O	
171	RxD0/SCPT[0]	I	Transmission data 0/input port for SCI
172	RxD1/SCPT[2]	I	Transmission data 1/input port for SCI
173	Vss	-	Power supply (0V)
-	Vss	-	Power supply (0V)
174	RxD2/SCPT[4]	I	Transmission data 2/input port for SCI
175	Vcc	-	Power supply (*3)
-	Vcc	-	Power supply (*3)
176	CTS2/IRQ5/SCPT[7]	I	Transmission clear 2/external interrupt request I/O port for SCI
177	MCS[7]/PTC[7]/PINT[7]	O/I/O	Mask ROM chip select/I/O port C/port interruption
178	MCS[6]/PTC[6]/PINT[6]	O/I/O	Mask ROM chip select/I/O port C/port interruption
179	MCS[5]/PTC[5]/PINT[5]	O/I/O	Mask ROM chip select/I/O port C/port interruption
180	MCS[4]/PTC[4]/PINT[4]	O/I/O	Mask ROM chip select/I/O port C/port interruption
181	VssQ	-	Power for I/O (0V)
182	WAKEUP/PTD[3]	O/I/O	Interrupt request notification on standby mode/I/O port D
183	VccQ	-	Power for I/O (3.3V)
184	RESETOUT/PTD[2]	O/I/O	Reset output/I/O port D
185	MCS[3]/PTC[3]/PINT[3]	O/I/O/I	Mask ROM chip select/I/O port C/port interruption
186	MCS[2]/PTC[2]/PINT[2]	O/I/O/I	Mask ROM chip select/I/O port C/port interruption
187	MCS[1]/PTC[1]/PINT[1]	O/I/O/I	Mask ROM chip select/I/O port C/port interruption
188	MCS[0]/PTC[0]/PINT[0]	O/I/O/I	Mask ROM chip select/I/O port C/port interruption
189	DRAK0/PTD[1]	O/I/O	DMA request accepting/I/O port D
190	DRAK1/PTD[0]	O/I/O	DMA request accepting/I/O port D
191	DREQ0/PTD[4]	I	DMA request/input port D
192	DREQ1/PTD[0]	I	DMA request/input port D
193	RESETP	I	Power on reset request
194	CA	I	Chip active (hardware standby request signal)
195	MD3	I	Bus width setting for area 0
196	MD4	I	Bus width setting for area 1
197	MD5	I	Endian setting
198	Avss	-	Power for analog (0V)
199	AN[0]/PTL[0]	I	AD converter input/input port L
200	AN[1]/PTL[1]	I	AD converter input/input port L
201	AN[2]/PTL[2]	I	AD converter input/input port L
202	AN[3]/PTL[3]	I	AD converter input/input port L
203	AN[4]/PTL[4]	I	AD converter input/input port L
204	AN[5]/PTL[5]	I	AD converter input/input port L
205	Avcc	-	Power for analog (3.3V)
206	AN[6]/DA[1]/PTL[6]	I	AD converter input/DA converter output/input port L
207	AN[7]/DA[0]/PTL[7]	I	AD converter input/DA converter output/input port L
208	AVss	-	Power for analog (0V)

14 TERMINAL GUIDE OF ICS, TRANSISTORS AND DIODES

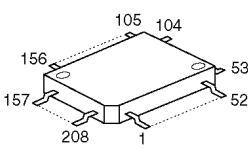
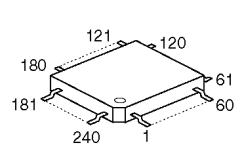
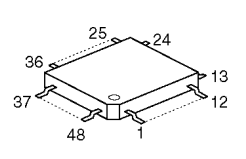
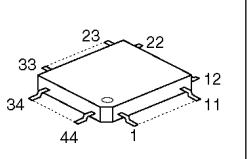
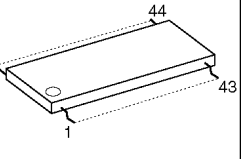
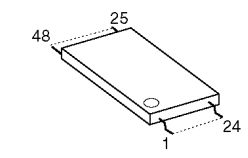
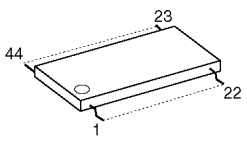
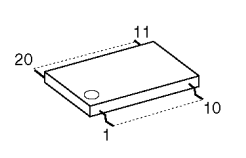
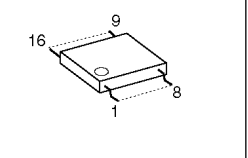
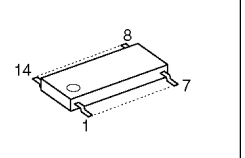
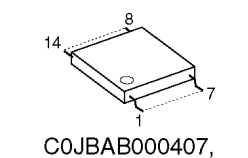
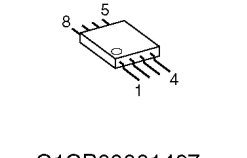
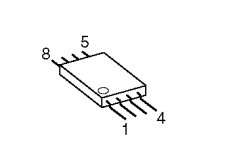
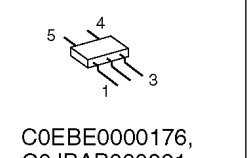
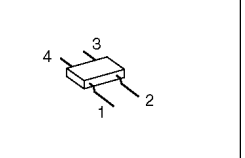
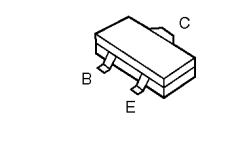
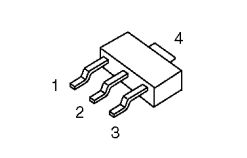
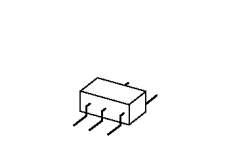
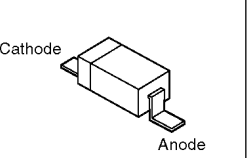
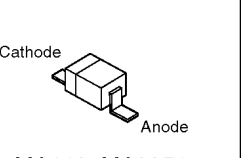
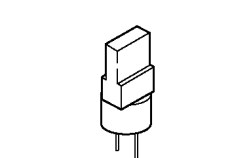
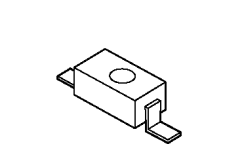
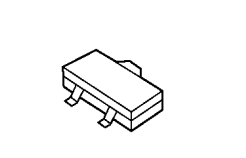
 <p>C2DBYJ000009</p>	 <p>C1CB00001395</p>	 <p>MN5773</p>	 <p>C1CB00001415</p>	 <p>C3ABPJ000054</p>
 <p>PSWITDA100BX</p>	 <p>C3BBKG000060</p>	 <p>C0JBAZ001765, C0ZBZ0000553</p>	 <p>C0JBAN000187</p>	 <p>PQVIMC1488MR, PQVIMC1489MR</p>
 <p>C0JBAB000407, C0JBAC000264, C0JBAA000174, C0JBAZ001704, C0JBAB000504</p>	 <p>C1CB00001497, PQVINJM4558M, PSVISV7560, PQVINJM2903M</p>	 <p>C0DBEDA000002</p>	 <p>C0EBE0000176, C0JBAB000381, PQVIS8520F33, C0CBAAG000006, C0CBADC000009</p>	 <p>C0CBAAB000022</p>
 <p>B1GBCFEH0003, UN5213, 2SC4081R, B1ABEC000005</p>	 <p>2SD1664Q, 2SB1132R, B1DFDC000002, B1DHCD000018</p>	 <p>B1GHCFJJ0007</p>	 <p>PFVDDGD1FP3T</p>	 <p>MA110, MA8051, MA8043M, MA8100M, MA1070400L, MA728</p>
 <p>LN316GP, LN216RP</p>	 <p>PSVD1VGCT, PSVD1SRCT</p>	 <p>MA143</p>		

15 HOW TO REPLACE A FLAT PACKAGE IC

15.1. PREPARATION

- PbF (: Pb free) Solder
- Soldering Iron

Tip Temperature of 700°F ± 20°F (370°C ± 10°C)

Note: We recommend a 30 to 40 Watt soldering iron. An expert may be able to use a 60 to 80 Watt iron where someone with less experience could overheat and damage the PCB foil.

- Flux

Recommended Flux: Specific Gravity → 0.82.

Type → RMA (lower residue, non-cleaning type)

Note: See **ABOUT LEAD FREE SOLDER (PbF: Pb free)** (P.3).

15.2. PROCEDURE

1. Tack the flat pack IC to the PCB by temporarily soldering two diagonally opposite pins in the correct positions on the PCB.

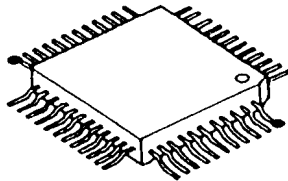

● - - - - - Temporary soldering point.

Be certain each pin is located over the correct pad on the PCB.

2. Apply flux to all of the pins on the IC.

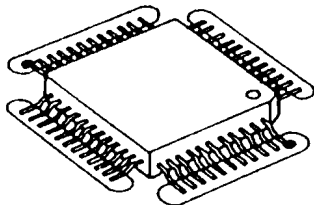

○ - - - - - Flux

3. Being careful to not unsolder the tack points, slide the soldering iron along the tips of the pins while feeding enough solder to the tip so that it flows under the pins as they are heated.

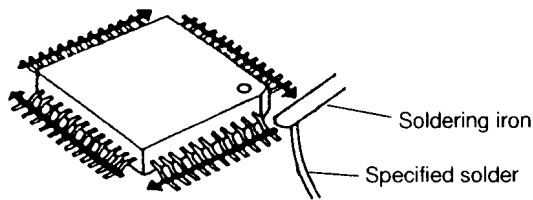

15.3. REMOVING SOLDER FROM BETWEEN PINS



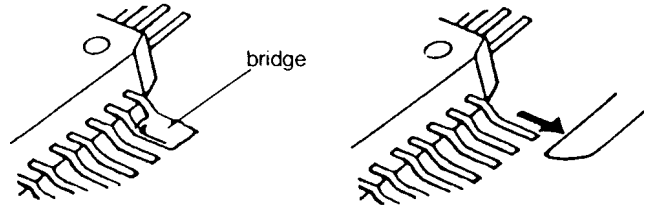

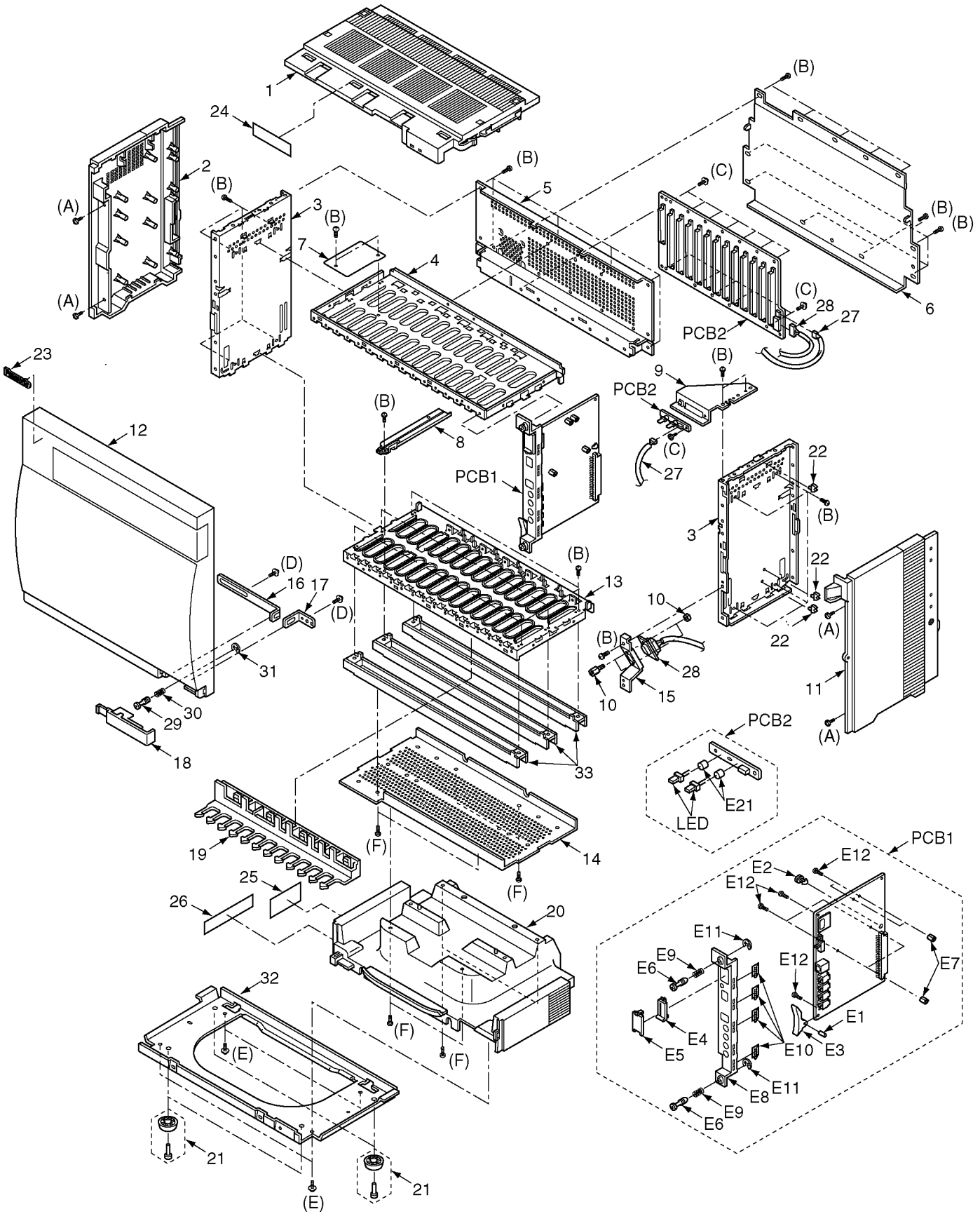

1. Add a small amount of solder to the bridged pins.
2. With a hot iron, use a sweeping motion along the flat part of the pin to draw the solder from between the adjacent pads.



16 CABINET AND ELECTRICAL PARTS LOCATION



SCREWS

Ref No.	Figure	Parts No.
(A)	 Φ3x8mm	XTW3+8LFZ
(B)	 Φ3x6mm	XTV3+6F
(C)	 Φ3x6mm	XYN3+F6
(D)	 Φ3x10mm	XTW3+W10P
(E)	 Φ4x12mm	XTW4+S12P
(F)	 Φ4x10mm	XTV4+10F

16.1. EXTENSION BOARDS FOR SERVICING

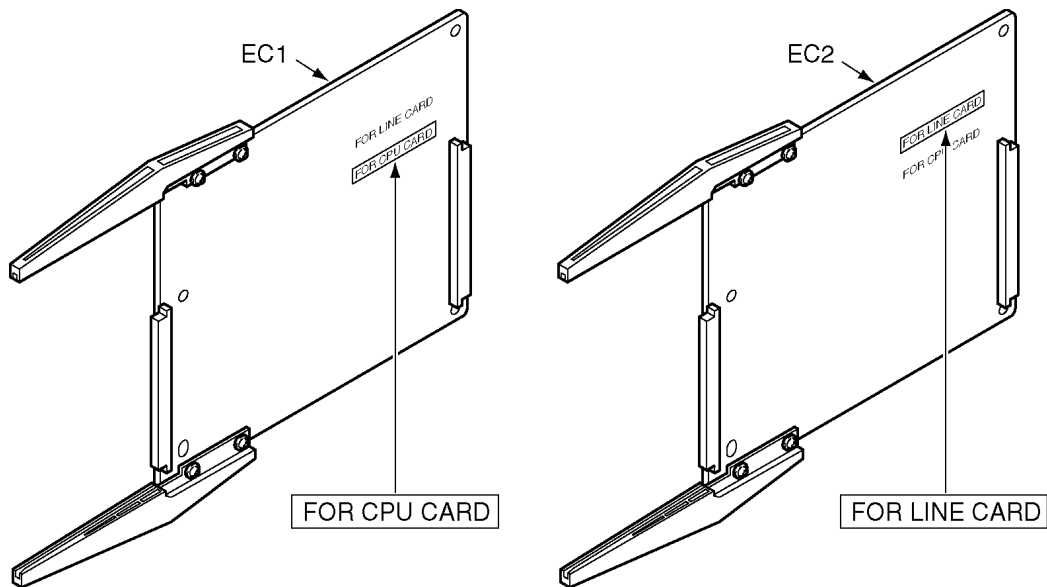

17 ACCESSORIES AND PACKING MATERIALS

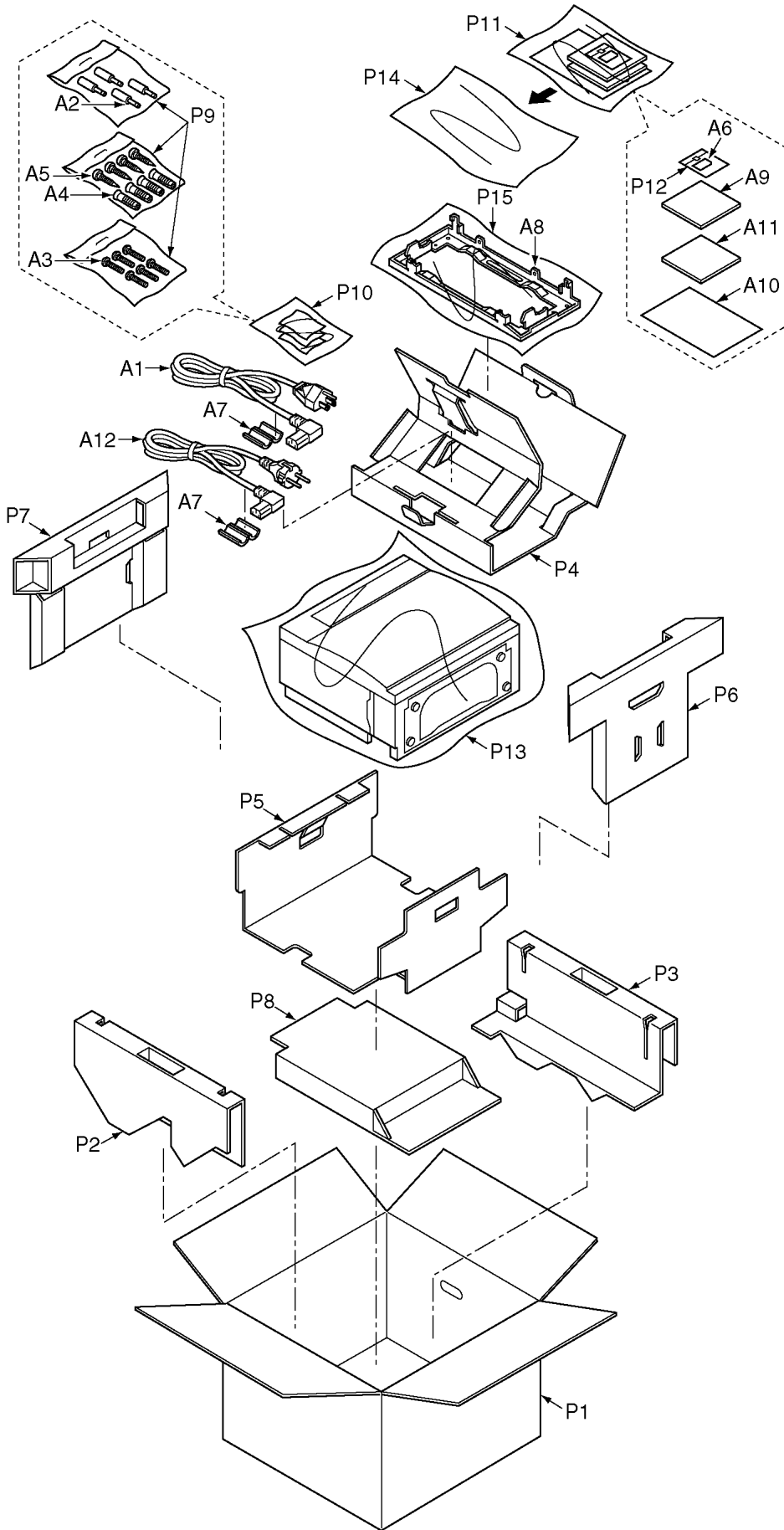

18 REPLACEMENT PARTS LIST

Note:

1. RTL (Retention Time Limited)

The marking (RTL) indicates that the Retention Time is limited for this item.

After the discontinuation of this assembly in production, the item will continue to be available for a specific period of time. The retention period of availability depends on the type of assembly and the laws governing parts and product retention. At the end of this period, the assembly will no longer be available.

2. Important safety notice

Components identified by the \triangle mark indicates special characteristics important for safety. When replacing any of these components, only use specified manufacture's parts.

3. The S mark means the part is one of some identical parts. For that reason, it may be different from the installed part.

4. ISO code (Example : ABS-94HB) of the remarks column shows quality of the material and a flame resisting grade about plastics.

5. RESISTORS & CAPACITORS

Unless otherwise specified;

All resistors are in ohms (Ω), k=1000 Ω , M=1000k Ω

All capacitors are in MICRO FARADS (μ F), p= μ (μ F)

*Type & Wattage of Resistor

Type

ERC:Solid	ERX:Metal Film	PQ4R:Carbon
ERD:Carbon	ERG:Metal Oxide	ERS:Fusible Resistor
PQRD:Carbon	ER0:Metal Film	ERF:Cement Resistor

Wattage

10,16:1/8W	14,25:1/4W	12:1/2W	1:1W	2:2W	3:3W
------------	------------	---------	------	------	------

*Type & Voltage of Capacitor

Type

ECFD:Semi-Conductor	ECCD,ECKD,ECBT,PQCBC: Ceramic
ECQS:Styrol	ECQE,ECQV,ECQG: Polyester
PQCUV:Chip	ECEA,ECSZ:Electlytic
ECQMS:Mica	ECQP: Polypropylene

Voltage

ECQ Type	ECQG ECQV Type	ECSZ Type	Others		
1H:50V	05:50V	0F:3.15V	0J :6.3V	1V :35V	
2A:100V	1:100V	1A:10V	1A :10V	50,1H:50V	
2E:250V	2:200V	1V:35V	1C :16V	1J :63V	
2H:500V		0J:6.3V	1E,25:25V	2A :100V	

18.1. CABINET AND ELECTRICAL PARTS

Ref. No.	Part No.	Part Name & Description	Remarks
1	PSKV1015Z1	COVER, TOP	PC+ABS-5V
2	PSKV1017Z1	COVER, LEFT SIDE	ABS-HB
3	PSMD1035Z	FRAME, SIDE	
4	PSMD1036Y	FRAME, BASE	
5	PSMH1200Z	FRAME, BACK BOARD	
6	PSMD1037Z	COVER, BACK	
7	PSMH1264Z	COVER, HOLD	
8	PSHR1235Z	GUIDE RAIL	PC+ABS-5V

Ref. No.	Part No.	Part Name & Description	Remarks
9	PSMH1205Z	CHASSIS, LED	
10	PSHD1091Z	BOLT WITH NUT	
11	PSKV1016Z1	COVER, RIGHT SIDE	ABS-HB
12	PSYCTDA200AL	COVER, FRONT	PC+ABS-5V
13	PSMD1036Y	FRAME, LOWER	
14	PSMH1198Z	FRAME	
15	PSMH1222Z	ANGLE, RS-232C	
16	PSMH1206Y	ANGLE	
17	PSMH1207Z	ANGLE	
18	PSKK1035Z1	LID	PC+ABS-5V
19	PSKR1001Z1	GUIDE, CABLE	PC+ABS-5V
20	PSKL1013Z1	STAND	
21	PSHA1008Z	LEG	ABS-HB
22	PQHR10379Z	CLAMPER	
23	PSGB1001Z	BADGE	PS-HB
24	PSQT1431Z	LABEL, WARNING	
25	PSYETDA200BX	NAME PLATE	
26	PSQT1949Z	LABEL, CAUTION	
27	PSJS03P16Z	CONNECTOR, LED	
28	PSJS09P12Z	CONNECTOR, RS-232C	
29	PQHD10011V	SCREW	
30	PSUS1022Z	SPRING	
31	XUC3VW	RETAINING RING	
32	PSMD1038Z	FRAME, BASE	
33	PSMH1201Z	ANGLE	

18.2. ACCESSORIES AND PACKING MATERIALS

Ref. No.	Part No.	Part Name & Description	Remarks
A1	PSJA1007Z	POWER CORD (AC CORD)	\triangle
A2	PQJP1E1Z	PLUG	
A3	XYN4+J18FZ	SCREW	
A4	PQHE17Z	MOUNTING BRACKET	
A5	XTB5+20AFY	SCREW	
A6	PSZETDA100BX	ACCESSORY PARTS, SD CARD	
A7	PSLB5D1	INSULATOR	
A8	PSMD1039Z	MOUNTING BRACKET	
A9	PSQX2227YCD	CD-ROM, INSTALLATION MANUAL (FOR USER)	
A10	PSQW2011Y	LEAFLET, SAFETY INFORMATI	
A11	PSQX2849ZCD	CD-ROM (FOR USER DEALER)	
A12	PSJA1081Z	POWER CORD (AC CORD)	\triangle
P1	PSZKTDA200BX	PACKING CASE	
P2	PSPD1157Z	CUSHION	
P3	PSPD1158Z	CUSHION	
P4	PSPN1125Y	ACCESSORY BOX	
P5	PSPD1180Z	CUSHION	
P6	PSPD1152Z	CUSHION	
P7	PSPD1151Y	CUSHION	
P8	PSPD1181Z	CUSHION	
P9	XZB05X08A03	PROTECTION COVER (FOR SCREW)	
P10	XZB10X15A04	PROTECTION COVER	
P11	XZB18X27A04	PROTECTION COVER (FOR CD-ROM)	
P12	PSPP1070Z	PROTECTION COVER (FOR SD CARD)	
P13	PQPP143Z	PROTECTION COVER (FOR SET)	
P14	PSPP1069Z	PROTECTION COVER	
P15	XZB50X30A06	PROTECTION COVER (FOR MOUNTING BRACKET)	

18.3. MPR CARD PARTS

Ref. No.	Part No.	Part Name & Description	Remarks
PCB1	PSWF1DA100BX	MPR CARD ASS'Y (RTL)	
		(ICS)	
IC101	C2DBYJ000009	IC	
IC102	C1CB00001395	IC	
IC103	C1CB00001497	IC	
IC107	C0EBE0000176	IC	
IC110	C0JBAB000407	IC	S
IC111	C0JBAB000407	IC	S
IC120	PQVIMC1488MR	IC	
IC121	PQVIMC1489MR	IC	
IC123	C0JBAZ001765	IC	
IC124	C0JBAZ001765	IC	
IC125	C0JBAC000264	IC	
IC126	C0JBAA000174	IC	
IC127	C0JBAZ001704	IC	S
IC131	C0JBAB000407	IC	S
IC132	C0JBAB000381	IC	
IC201	C0JBAN000187	IC	S
IC204	C1CB00001415	IC	
IC205	MN5773	IC	
IC207	C0JBAZ001765	IC	
IC208	C0JBAZ001765	IC	
IC209	C0JBAB000504	IC	
IC301	C3BBKG000060	IC	S
IC302	C3BBKG000060	IC	S
IC303	PSWITDA100BX	IC (ROM)	
IC305	C3ABPJ000054	IC	S
IC306	C3ABPJ000054	IC	S
IC309	C0JBAN000187	IC	
IC310	C0JBAN000187	IC	
IC311	C0JBAA000174	IC	
IC402	PQVIS8520F33	IC	
IC403	C0CBAAG00006	IC	
IC404	C0CBAAB00022	IC	
IC405	C0ZBZ0000553	IC	
IC406	C0ZBZ0000553	IC	
IC408	PQVINJM4558M	IC	
IC409	PQVINJM4558M	IC	
IC410	PSVISV7560	IC	
IC411	PQVINJM2903M	IC	
IC412	C0CBADC00009	IC	
IC413	C0DBEDA00002	IC	
		(TRANSISTORS)	
Q101	B1GBCFEH0003	TRANSISTOR (SI)	
Q403	2SD1664Q	TRANSISTOR (SI)	
Q404	2SB1132R	TRANSISTOR (SI)	
Q405	2SB1132R	TRANSISTOR (SI)	
Q406	UN5213	TRANSISTOR (SI)	
Q407	2SC4081R	TRANSISTOR (SI)	
Q408	2SC4081R	TRANSISTOR (SI)	
Q409	B1ABEC000005	TRANSISTOR (SI)	
Q410	B1ABEC000005	TRANSISTOR (SI)	
Q411	B1DFDC000002	TRANSISTOR (SI)	
Q412	B1DHCD000018	TRANSISTOR (SI)	
QA101	B1GHCFJJ0007	TRANSISTOR (SI)	S
QA103	B1GHCFJJ0007	TRANSISTOR (SI)	S
		(DIODES)	
D102	MA110	DIODE (SI)	
D402	PFVDDGD1FP3T	DIODE (SI)	
D403	MA8100M	DIODE (SI)	
D405	MA8051	DIODE (SI)	
D406	MA8043M	DIODE (SI)	
D407	MA1070400L	DIODE (SI)	
D408	MA728	DIODE (SI)	

Ref. No.	Part No.	Part Name & Description	Remarks
D409	MA728	DIODE (SI)	
DA401	MA143	DIODE (SI)	
DA402	MA143	DIODE (SI)	
LED101	PSVD1VGCT	LED	
LED103	PSVD1SRCT	LED	
		(CONNECTORS)	
CN103	K1KA90B00008	CONNECTOR, 90P	
CN205	K1KAC0A00037	CONNECTOR, 120P	
CN206	K1KB30A00117	CONNECTOR, 30P	
CN207	PSJP07A44Z	CONNECTOR, 7P	
CN209	K1KB04B00036	CONNECTOR, 4P	S
CN211	K1NA09E00022	CONNECTOR, 9P	
		(JACKS)	
JK401	PSJJ1D001Z	JACK	S
JK402	PSJJ1D001Z	JACK	S
JK403	PSJJ1D001Z	JACK	S
JK404	PSJJ1D001Z	JACK	S
		(COMPONENTS PARTS)	
RA101	D1HA1038A005	RESISTOR ARRAY	
RA102	D1H8R0040009	RESISTOR ARRAY	
RA103	D1H8R0040009	RESISTOR ARRAY	
RA104	D1H8R0040009	RESISTOR ARRAY	
RA105	D1H8R0040009	RESISTOR ARRAY	
RA106	D1H8R0040009	RESISTOR ARRAY	
RA107	D1H8R0040009	RESISTOR ARRAY	
RA108	D1H8R0040009	RESISTOR ARRAY	
RA109	D1H8R0040009	RESISTOR ARRAY	
RA111	EXB38VR000	RESISTOR ARRAY	
RA112	EXB38VR000	RESISTOR ARRAY	
RA113	EXB38VR000	RESISTOR ARRAY	
RA114	EXB38VR000	RESISTOR ARRAY	
RA115	EXB38VR000	RESISTOR ARRAY	
RA116	EXB38VR000	RESISTOR ARRAY	
RA117	D1HA1038A005	RESISTOR ARRAY	
RA118	D1HA1038A005	RESISTOR ARRAY	
RA119	D1HA1038A005	RESISTOR ARRAY	
RA120	D1HA1038A005	RESISTOR ARRAY	
RA121	D1HA1038A005	RESISTOR ARRAY	
RA122	D1HA1038A005	RESISTOR ARRAY	
RA123	EXB38V680JV	RESISTOR ARRAY	
RA124	EXB38V680JV	RESISTOR ARRAY	
RA125	EXB38V680JV	RESISTOR ARRAY	
RA126	EXB38V680JV	RESISTOR ARRAY	
RA127	EXB38V680JV	RESISTOR ARRAY	
RA128	EXRV8V470JV	RESISTOR ARRAY	
RA129	EXRV8V470JV	RESISTOR ARRAY	
RA133	D1HA1038A005	RESISTOR ARRAY	
RA134	D1HA1038A005	RESISTOR ARRAY	
RA135	D1HA1038A005	RESISTOR ARRAY	
RA136	EXB38V222JV	RESISTOR ARRAY	
RA137	EXB38V103JV	RESISTOR ARRAY	
RA201	D1HA1048A005	RESISTOR ARRAY	S
RA202	EXB38V220JV	RESISTOR ARRAY	
RA203	EXB38V220JV	RESISTOR ARRAY	
RA204	D1H82204A024	RESISTOR ARRAY	
RA205	D1H82204A024	RESISTOR ARRAY	
RA206	D1H82204A024	RESISTOR ARRAY	
RA207	D1H82204A024	RESISTOR ARRAY	
RA301	D1HA1038A005	RESISTOR ARRAY	
RA302	D1HA1038A005	RESISTOR ARRAY	
RA303	D1HA1038A005	RESISTOR ARRAY	
RA304	D1HA1038A005	RESISTOR ARRAY	
RA305	D1HA1038A005	RESISTOR ARRAY	

Ref. No.	Part No.	Part Name & Description	Remarks
RA306	DIHA1038A005	RESISTOR ARRAY	
RA307	DIHA1038A005	RESISTOR ARRAY	
RA308	DIHA1038A005	RESISTOR ARRAY	
RA309	DIHA1038A005	RESISTOR ARRAY	
		(CAPACITORS)	
C101	PQCUV1A225ZF	2.2	
C102	ECUV1A105ZVF	1	
C103	ECUV1C104ZVF	0.1	
C104	ECUV1C104ZVF	0.1	
C105	ECUV1C104ZVF	0.1	
C106	ECUV1C104ZVF	0.1	
C107	ECUV1C104ZVF	0.1	
C108	ECUV1C104ZVF	0.1	
C109	ECUV1H120JCV	12p	
C110	ECUV1C104ZVF	0.1	
C111	ECUV1C104ZVF	0.1	
C112	ECUV1C104ZVF	0.1	
C114	ECUV1H120JCV	12p	
C116	ECUV1C104ZVF	0.1	
C117	ECUV1C104ZVF	0.1	
C118	ECUV1C104ZVF	0.1	
C119	ECUV1C104ZVF	0.1	
C120	ECUV1C104ZVF	0.1	
C121	ECUV1A105ZVF	1	
C122	ECUV1A105ZVF	1	
C123	ECUV1A105ZVF	1	
C124	ECUV1C104ZVF	0.1	
C125	ECUV1C104ZVF	0.1	
C126	PQCUV1A225ZF	2.2	
C127	PQCUV1A225ZF	2.2	
C128	PQCUV1A225ZF	2.2	
C129	ECUV1A105ZVF	1	
C130	ECUV1A105ZVF	1	
C131	PQCUV1A225ZF	2.2	
C132	PQCUV1A225ZF	2.2	
C133	PQCUV1A225ZF	2.2	
C134	PQCUV1A225ZF	2.2	
C135	ECUV1H220JCV	22p	
C136	ECUV1H220JCV	22p	
C137	ECUV1H471JCV	470p	
C138	ECUV1H471JCV	470p	
C139	ECUV1C104ZVF	0.1	
C140	ECUV1A105ZVF	1	
C141	ECUV1C104ZVF	0.1	
C142	ECUV1C104ZVF	0.1	
C143	PQCUV1A225ZF	2.2	
C144	ECUV1C104ZVF	0.1	
C145	ECUV1C104ZVF	0.1	
C146	ECUV1C104ZVF	0.1	
C147	ECUV1C104ZVF	0.1	
C148	ECUV1C104ZVF	0.1	
C149	ECUV1C104ZVF	0.1	
C150	ECUV1A105ZVF	1	
C151	PQCUV1A225ZF	2.2	
C156	ECUV1H102KBV	0.001	
C157	ECUV1H102KBV	0.001	
C159	ECUV1C104ZVF	0.1	
C160	ECUV1A105ZVF	1	
C161	ECUV1C104ZVF	0.1	
C162	ECUV1C104ZVF	0.1	
C163	ECUV1C104ZVF	0.1	
C166	ECUV1C104ZVF	0.1	
C167	ECUV1C104ZVF	0.1	
C168	ECUV1H102KBV	0.001	
C170	ECUV1C104ZVF	0.1	

Ref. No.	Part No.	Part Name & Description	Remarks
C174	ECUV1C104ZVF	0.1	
C201	ECUV1H220JCV	22p	
C202	PQCUV1A225ZF	2.2	
C203	ECUV1H220JCV	22p	
C204	ECUV1A105ZVF	1	
C205	ECUV1C104ZVF	0.1	
C206	ECUV1C104ZVF	0.1	
C207	ECUV1C104ZVF	0.1	
C208	ECUV1C104ZVF	0.1	
C209	PQCUV1A225ZF	2.2	
C210	ECUV1A105ZVF	1	
C211	ECUV1C104ZVF	0.1	
C212	ECUV1C105ZVF	1	
C214	ECUV1C104ZVF	0.1	
C215	ECUV1C104ZVF	0.1	
C216	ECUV1C104ZVF	0.1	
C217	ECUV1H150JCV	15p	
C218	ECUV1H150JCV	15p	
C219	ECUV1C104ZVF	0.1	
C220	ECUV1A105ZVF	1	
C301	PQCUV1A225ZF	2.2	
C302	PQCUV1A225ZF	2.2	
C303	ECUV1A105ZVF	1	
C304	ECUV1A105ZVF	1	
C305	ECUV1C104ZVF	0.1	
C306	ECUV1C104ZVF	0.1	
C307	ECUV1H102KBV	0.001	
C308	ECUV1C104ZVF	0.1	
C310	ECUV1A105ZVF	1	
C312	PQCUV1A225ZF	2.2	
C314	ECUV1C104ZVF	0.1	
C315	ECUV1A105ZVF	1	
C316	PQCUV1A225ZF	2.2	
C317	ECUV1C104ZVF	0.1	
C318	ECUV1A105ZVF	1	
C319	PQCUV1A225ZF	2.2	
C320	ECUV1C104ZVF	0.1	
C321	ECUV1C104ZVF	0.1	
C322	ECUV1C104ZVF	0.1	
C402	F2G1E3310005	330	
C403	ECUV1C104ZVF	0.1	
C404	ECUV1C104ZVF	0.1	
C406	ECUV1C104ZVF	0.1	
C408	F2G0J4710006	470	
C410	ECUV1C104ZVF	0.1	
C411	ECUV1C104ZVF	0.1	
C412	ECUV1C104ZVF	0.1	
C413	ECUV1H103KBV	0.01	
C414	ECUV1C104ZVF	0.1	
C415	ECUV1H103KBV	0.01	
C416	PQCUV1A225ZF	2.2	
C417	PSCSZLAX106M	10	
C418	ECUV1A105ZVF	1	
C419	ECUV1H121JCV	120p	
C420	ECUV1A105ZVF	1	
C421	ECUV1H121JCV	120p	
C422	ECUV1C104ZVF	0.1	
C423	ECUV1C104ZVF	0.1	
C424	ECUV1C104ZVF	0.1	
C425	ECUV1C104ZVF	0.1	
C426	ECUV1C104ZVF	0.1	
C427	ECUV1C104ZVF	0.1	
C428	ECUV1C104ZVF	0.1	
C429	ECUV1C104ZVF	0.1	

Ref. No.	Part No.	Part Name & Description	Remarks
C430	ECUV1H153KBV	0.015	
C431	ECUV1H153KBV	0.015	
C433	ECUV1C104ZFV	0.1	
C435	ECUV1A105ZFV	1	
C436	ECUV1A105ZFV	1	
C437	ECUV1H333KBV	0.033	
C438	ECUV1H333KBV	0.033	
C439	ECUV1H102KBV	0.001	
C440	ECUV1H102KBV	0.001	
C441	ECUV1H332KBV	0.0033	
C442	ECUV1H105ZF	1	
C443	ECUV1H105ZF	1	
C444	ECUV1H332KBV	0.0033	
C445	ECUV1H105ZF	1	
C446	ECUV1H105ZF	1	
C447	ECUV1H105ZF	1	
C448	ECUV1H105ZF	1	
C449	ECUV1H105ZF	1	
C450	ECUV1H105ZF	1	
C451	PQCUV1C105ZF	1	
C452	PQCUV1C105ZF	1	
C453	F2G1H1000010	10	
C454	F2G1H1000010	10	
C455	ERJ3GEY0R00	0 (RESISTOR)	
C465	ECUV1C104ZFV	0.1	
C466	ECUV1C104ZFV	0.1	
C467	ECUV1H102KBV	0.001	
C468	ECUV1H102KBV	0.001	
C469	ECUV1H102KBV	0.001	
C470	ECUV1H102KBV	0.001	
		(RESISTORS)	
R103	ERJ3GEYJ332	3.3k	
R104	ERJ3GEY0R00	0	
R105	ERJ3GEYJ471	470	
R106	ERJ3GEY0R00	0	
R107	ERJ3GEY0R00	0	
R108	ERJ3GEY0R00	0	
R109	ERJ3GEY0R00	0	
R110	ERJ3GEY0R00	0	
R111	ERJ3GEY0R00	0	
R112	ERJ3GEY0R00	0	
R113	ERJ3GEY0R00	0	
R114	ERJ3GEY0R00	0	
R117	ERJ3GEY0R00	0	
R118	ERJ3GEY0R00	0	
R119	ERJ3GEYJ220	22	
R120	ERJ3GEY0R00	0	
R121	ERJ3GEY0R00	0	
R122	ERJ3GEY0R00	0	
R123	ERJ3GEY0R00	0	
R124	ERJ3GEY0R00	0	
R125	ERJ3GEY0R00	0	
R126	ERJ3GEYJ103	10k	
R127	ERJ3GEYJ103	10k	
R128	ERJ3GEYJ102	1k	
R129	ERJ3GEY0R00	0	
R130	ERJ3GEYJ102	1k	
R131	ERJ3GEY0R00	0	
R132	ERJ3GEYJ102	1k	
R133	ERJ3GEYJ182	1.8k	
R134	ERJ3GEYJ103	10k	
R135	ERJ3GEY0R00	0	
R136	ERJ3GEY0R00	0	

Ref. No.	Part No.	Part Name & Description	Remarks
R137	ERJ3GEYJ103	10k	
R138	ERJ3GEYJ103	10k	
R139	ERJ3GEYJ103	10k	
R140	ERJ3GEYJ330	33	
R142	ERJ3GEYJ330	33	
R143	ERJ3GEYJ330	33	
R144	ERJ3GEYJ470	47	
R145	ERJ3GEYJ470	47	
R146	ERJ3GEYJ680	68	
R148	ERJ3GEYJ103	10k	
R150	ERJ3GEYJ332	3.3k	
R151	ERJ3GEYJ332	3.3k	
R152	ERJ3GEYJ332	3.3k	
R153	ERJ3GEYJ332	3.3k	
R155	ERJ3GEYJ182	1.8k	
R156	ERJ3GEYJ182	1.8k	
R157	ERJ3GEYJ182	1.8k	
R159	ERJ3GEYJ680	68	
R164	ERJ3GEYJ470	47	
R165	ERJ3GEYJ470	47	
R166	ERJ3GEYJ332	3.3k	
R167	ERJ3GEYJ332	3.3k	
R168	ERJ3GEYJ332	3.3k	
R170	ERJ3GEYJ332	3.3k	
R171	ERJ3GEYJ102	1k	
R172	ERJ3GEYJ103	10k	
R173	ERJ3GEYJ102	1k	
R174	ERJ3GEYJ102	1k	
R175	ERJ3GEYJ182	1.8k	
R176	ERJ3GEYJ681	680	
R178	ERJ3GEYJ102	1k	
R179	ERJ3GEYJ222	2.2k	
R180	ERJ3GEYJ222	2.2k	
R181	ERJ3GEYJ102	1k	
R182	ERJ3GEYJ223	22k	
R183	ERJ3GEYJ821	820	
R184	ERJ3GEYJ821	820	
R185	ERJ3GEYJ821	820	
R186	ERJ3GEYJ821	820	
R187	ERJ3GEYJ821	820	
R188	ERJ3GEYJ821	820	
R189	ERJ3GEYJ101	100	
R190	ERJ3GEYJ101	100	
R191	ERJ3GEYJ220	22	
R192	ERJ3GEYJ220	22	
R193	ERJ3GEYJ220	22	
R194	ERJ3GEYJ220	22	
R195	ERJ3GEYJ101	100	
R196	ERJ3GEYJ101	100	
R197	ERJ3GEYJ101	100	
R198	ERJ3GEYJ472	4.7k	
R199	ERJ3GEYJ102	1k	
R203	ERJ3GEYJ330	33	
R204	ERJ3GEYJ330	33	
R205	ERJ3GEYJ330	33	
R206	ERJ3GEYJ330	33	
R207	ERJ3GEYJ105	1M	
R208	ERJ3GEYJ681	680	
R214	ERJ3GEYJ152	1.5k	
R226	ERJ3GEYJ220	22	
R227	ERJ3GEYJ220	22	
R236	ERJ3GEYJ562	5.6k	
R238	ERJ3GEYJ103	10k	
R239	ERJ3GEYJ473	47k	
R240	ERJ3GEYJ473	47k	

Ref. No.	Part No.	Part Name & Description	Remarks
R241	ERJ3GEYJ473	47k	
R242	ERJ3GEYJ473	47k	
R243	ERJ3GEYJ104	100k	
R244	ERJ3GEYJ472	4.7k	
R245	ERJ3GEYJ473	47k	
R246	ERJ3GEYJ473	47k	
R247	ERJ3GEYJ102	1k	
R248	ERJ3GEYJ105	1M	
R250	ERJ3GEYJ330	33	
R251	ERJ3GEYJ104	100k	
R302	ERJ3GEYJ103	10k	
R303	ERJ3GEYJ103	10k	
R304	ERJ3GEYJ103	10k	
R305	ERJ3GEYJ103	10k	
R306	ERJ3GEYJ103	10k	
R307	ERJ3GEYJ103	10k	
R401	ERJ3GEYJ103	10k	
R403	ERJ3GEYJ560	56	
R406	ERJ3GEYJ102	1k	
R409	ERJ3GEY0R00	0	
R410	ERJ3GEYJ681	680	
R411	ERJ3GEYJ681	680	
R412	ERJ3GEYJ682	6.8k	
R413	ERJ3GEYJ102	1k	
R414	ERJ3GEYJ222	2.2k	
R415	ERJ3GEYJ103	10k	
R416	ERJ3GEYJ222	2.2k	
R417	ERJ3GEYJ681	680	
R418	ERJ3GEYJ222	2.2k	
R419	ERJ3GEYJ103	10k	
R420	ERJ3GEYJ103	10k	
R421	ERJ3GEYJ106	10M	
R422	ERJ3GEYJ472	4.7k	
R423	ERJ3GEYJ563	56k	
R424	ERJ3GEYJ563	56k	
R425	ERJ3GEYJ563	56k	
R426	ERJ3GEYJ563	56k	
R427	ERJ3GEYJ104	100k	
R428	ERJ3GEYJ104	100k	
R429	ERJ3GEYJ561	560	
R430	ERJ3GEYJ561	560	
R431	ERJ3GEYJ561	560	
R432	ERJ3GEYJ561	560	
R433	ERJ3GEYJ104	100k	
R434	ERJ3GEYJ473	47k	
R435	ERJ3GEYJ333	33k	
R436	ERJ3GEYJ333	33k	
R437	ERJ3GEYJ223	22k	
R438	ERJ3GEYJ223	22k	
R439	ERJ3GEYJ223	22k	
R440	ERJ3GEYJ223	22k	
R441	ERJ3GEYJ223	22k	
R442	ERJ3GEYJ103	10k	
R443	ERJ3GEYJ103	10k	
R444	ERJ3GEYJ823	82k	
R445	ERJ3GEYJ823	82k	
R446	ERJ3GEYJ103	10k	
R447	ERJ3GEYJ103	10k	
R448	ERJ3GEYJ105	1M	
R449	ERJ3GEYJ105	1M	
R450	ERJ3GEYJ823	82k	
R451	ERJ3GEYJ823	82k	
R452	ERJ3GEYJ222	2.2k	
R453	ERJ3GEYJ223	22k	
R454	ERJ3GEYJ222	2.2k	

Ref. No.	Part No.	Part Name & Description	Remarks
R455	ERJ3GEYJ223	22k	
R456	ERJ3GEYJ223	22k	
R457	ERJ3GEYJ223	22k	
R458	ERJ3GEYJ472	4.7k	
R459	ERJ3GEYJ472	4.7k	
R460	ERJ3GEYJ222	2.2k	
R461	ERJ3GEYJ222	2.2k	
R462	ERJ3GEYJ473	47k	
R463	ERJ3GEYJ473	47k	
R464	ERJ3GEY0R00	0	
R465	ERJ3GEY0R00	0	
R468	ERJ3GEYJ106	10M	
R501	ERJ3GEYJ103	10k	
R502	ERJ3GEYJ103	10k	
R503	ERJ3GEYJ681	680	
R504	ERJ3GEYJ681	680	
R505	ERJ3GEYJ103	10k	
R506	ERJ3GEYJ103	10k	
R507	ERJ3GEYJ103	10k	
R508	ERJ3GEYJ103	10k	
R509	ERJ3GEYJ103	10k	
R510	ERJ3GEYJ103	10k	
R511	ERJ3GEYJ103	10k	
R512	ERJ3GEYJ103	10k	
R513	ERJ3GEYJ103	10k	
R514	ERJ3GEYJ103	10k	
R515	ERJ3GEYJ103	10k	
R516	ERJ3GEYJ103	10k	
R517	ERJ3GEYJ103	10k	
R518	ERJ3GEYJ103	10k	
R519	ERJ3GEYJ821	820	
R520	ERJ3GEYJ102	1k	
R521	ERJ3GEYJ222	2.2k	
R522	ERJ3GEYJ102	1k	
R523	ERJ3GEY0R00	0	
R525	ERJ3GEYJ103	10k	
R526	ERJ3GEYJ103	10k	
R527	ERJ3GEYJ220	22	
R528	ERJ3GEYJ220	22	
R529	ERJ3GEYJ103	10k	
R530	ERJ3GEYJ103	10k	
R531	ERJ3GEYJ103	10k	
R532	ERJ3GEYJ103	10k	
R549	ERJ3GEYJ103	10k	
R553	ERJ3GEYJ680	68	
R554	ERJ3GEYJ103	10k	
R555	ERJ3GEYJ103	10k	
R556	ERJ3GEYJ103	10k	
R557	ERJ3GEYJ103	10k	
R558	ERJ3GEYJ103	10k	
R559	ERJ3GEYJ103	10k	
R562	ERJ3GEYJ103	10k	
R563	ERJ3GEYJ103	10k	
R564	ERJ3GEYJ101	100	
R565	ERJ3GEYJ101	100	
R566	ERJ3GEYJ220	22	
R567	ERJ3GEY0R00	0	
R568	ERJ3GEY0R00	0	
R569	ERJ3GEYJ103	10k	
J105	ERJ3GEYJ223	22k	
J109	ERJ3GEY0R00	0	
J110	ERJ3GEY0R00	0	
J113	PQ4R18XJ000	0	
J114	PQ4R18XJ000	0	

Ref. No.	Part No.	Part Name & Description	Remarks
J115	PQ4R18XJ000	0	
J116	PQ4R18XJ000	0	
J121	ERJ3GEY0R00	0	
J123	ERJ3GEY0R00	0	
J126	ERJ3GEY0R00	0	
J129	ERJ3GEY0R00	0	
J130	ERJ3GEY0R00	0	
J131	ERJ3GEY0R00	0	
J133	ERJ3GEY0R00	0	
J155	ERJ3GEY0R00	0	
J157	ERJ3GEY0R00	0	
J162	ERJ3GEY0R00	0	
J210	ERJ3GEY0R00	0	
J211	ERJ3GEY0R00	0	
J212	ERJ3GEY0R00	0	
J213	ERJ3GEY0R00	0	
J216	ERJ3GEY0R00	0	
J301	ERJ3GEY0R00	0	
J303	ERJ3GEY0R00	0	
J305	ERJ3GEY0R00	0	
J307	ERJ3GEY0R00	0	
J309	ERJ3GEY0R00	0	
J311	ERJ3GEY0R00	0	
J315	ERJ3GEY0R00	0	
J330	ERJ3GEY0R00	0	
J331	ERJ3GEY0R00	0	
J411	ERJ3GEY0R00	0	
DIP02	ERJ3GEY0R00	0	
		(FILTERS ,COILS AND RESISTORS)	
FIL101	JOHAAH000003	CERAMIC FILTER	
FIL102	JOHAAB000020	IC FILTER	
FIL103	JOHAAH000003	CERAMIC FILTER	
FIL104	JOHAAH000003	CERAMIC FILTER	
FIL106	JOHAAB000020	IC FILTER	
FIL107	JOHAAH000003	CERAMIC FILTER	
FIL108	JOHAAB000020	IC FILTER	
FIL109	JOHAAH000003	CERAMIC FILTER	
FIL110	JOHAAB000020	IC FILTER	
FIL111	JOHAAH000003	CERAMIC FILTER	
FIL201	JOHAAH000003	CERAMIC FILTER	
FIL207	JOHAAH000003	CERAMIC FILTER	
FIL208	JOHAAB000020	IC FILTER	
FIL209	JOHAAH000003	CERAMIC FILTER	
FIL301	JOHAAH000003	CERAMIC FILTER	
FIL302	JOHAAH000003	CERAMIC FILTER	
FIL303	JOHAAH000003	CERAMIC FILTER	
FIL305	JOHAAH000003	CERAMIC FILTER	
FIL306	JOHAAH000003	CERAMIC FILTER	
FIL401	G1BYYC00007	COIL	
FIL402	G1BYYC00007	COIL	
FIL403	G1BYYC00007	COIL	
FIL404	G1BYYC00007	COIL	
L101	J0JCC0000042	COIL	
L102	J0JCC0000042	COIL	
L103	J0JCC0000042	COIL	
L105	ERJ3GEY0R00	0	
L106	ERJ3GEY0R00	0	
L107	ERJ3GEY0R00	0	
L108	ERJ3GEY0R00	0	
L109	ERJ3GEY0R00	0	
L110	ERJ3GEY0R00	0	
L113	ERJ3GEY0R00	0	
L114	ERJ3GEY0R00	0	

Ref. No.	Part No.	Part Name & Description	Remarks
L115	ERJ3GEY0R00	0	
L116	ERJ3GEY0R00	0	
L117	ERJ3GEY0R00	0	
L118	ERJ3GEY0R00	0	
L119	ERJ3GEY0R00	0	
L120	ERJ3GEY0R00	0	
L121	ERJ3GEY0R00	0	
L122	ERJ3GEY0R00	0	
L123	ERJ3GEY0R00	0	
L124	ERJ3GEY0R00	0	
L125	ERJ3GEY0R00	0	
L126	ERJ3GEY0R00	0	
L127	ERJ3GEY0R00	0	
L128	ERJ3GEY0R00	0	
L129	ERJ3GEY0R00	0	
L130	ERJ3GEY0R00	0	
L131	ERJ3GEY0R00	0	
L132	ERJ3GEY0R00	0	
L133	ERJ3GEY0R00	0	
L134	ERJ3GEY0R00	0	
L135	ERJ3GEY0R00	0	
L136	ERJ3GEY0R00	0	
L137	ERJ3GEY0R00	0	
L138	ERJ3GEY0R00	0	
L139	ERJ3GEY0R00	0	
L140	ERJ3GEY0R00	0	
L141	ERJ3GEY0R00	0	
L142	ERJ3GEY0R00	0	
L143	ERJ3GEY0R00	0	
L144	ERJ3GEY0R00	0	
L145	ERJ3GEY0R00	0	
L146	ERJ3GEY0R00	0	
L147	ERJ3GEY0R00	0	
L148	PFVFB221SB	CERAMIC FILTER	
L149	PFVFB221SB	CERAMIC FILTER	
L150	PFVFB221SB	CERAMIC FILTER	
L151	PFVFB221SB	CERAMIC FILTER	
L152	PFVFB221SB	CERAMIC FILTER	
L153	PFVFB221SB	CERAMIC FILTER	
L154	PFVFB221SB	CERAMIC FILTER	
L155	PFVFB221SB	CERAMIC FILTER	
L156	PFVFB221SB	CERAMIC FILTER	
L157	PFVFB221SB	CERAMIC FILTER	
L158	PFVFB221SB	CERAMIC FILTER	
L159	PFVFB221SB	CERAMIC FILTER	
L160	PFVFB221SB	CERAMIC FILTER	
L161	PFVFB221SB	CERAMIC FILTER	
L162	PFVFB221SB	CERAMIC FILTER	
L163	PFVFB221SB	CERAMIC FILTER	
L164	PFVFB221SB	CERAMIC FILTER	
L165	PFVFB221SB	CERAMIC FILTER	
L166	PFVFB221SB	CERAMIC FILTER	
L167	PFVFB221SB	CERAMIC FILTER	
L168	PFVFB221SB	CERAMIC FILTER	
L169	PFVFB221SB	CERAMIC FILTER	
L170	PFVFB221SB	CERAMIC FILTER	
L171	PFVFB221SB	CERAMIC FILTER	
L172	PFVFB221SB	CERAMIC FILTER	
L173	PFVFB221SB	CERAMIC FILTER	
L174	PFVFB221SB	CERAMIC FILTER	
L175	PFVFB221SB	CERAMIC FILTER	
L176	PFVFB221SB	CERAMIC FILTER	
L177	PFVFB221SB	CERAMIC FILTER	
L183	PFVFA471SG	CERAMIC FILTER	
L184	PFVFA471SG	CERAMIC FILTER	
L185	PFVFA471SG	CERAMIC FILTER	

Ref. No.	Part No.	Part Name & Description	Remarks
L186	PFVFLA471SG	CERAMIC FILTER	
L187	PFVFLA471SG	CERAMIC FILTER	
L189	PFVFB1470SB	CERAMIC FILTER	
L190	PFVFB1470SB	CERAMIC FILTER	
L191	PQ4R10XJ000	0	
L192	PQ4R10XJ000	0	
L193	PQ4R10XJ000	0	
L194	PQ4R10XJ000	0	
L195	PQ4R10XJ000	0	
L196	PQ4R10XJ000	0	
L211	ERJ3GEY0R00	0	
L212	ERJ3GEY0R00	0	
L213	ERJ3GEY0R00	0	
L214	ERJ3GEY0R00	0	
L215	ERJ3GEY0R00	0	
L216	ERJ3GEY0R00	0	
L217	ERJ3GEY0R00	0	
L218	ERJ3GEY0R00	0	
L219	ERJ3GEY0R00	0	
L220	ERJ3GEY0R00	0	
L221	ERJ3GEY0R00	0	
L222	ERJ3GEY0R00	0	
L223	ERJ3GEY0R00	0	
L224	ERJ3GEY0R00	0	
L225	ERJ3GEY0R00	0	
L226	ERJ3GEY0R00	0	
L227	PQ4R10XJ000	0	
L228	PQ4R10XJ000	0	
L229	PQ4R10XJ000	0	
L301	PQ4R10XJ000	0	
L302	PQ4R10XJ000	0	
L303	PQ4R10XJ000	0	
L305	PQ4R10XJ000	0	
L306	PQ4R10XJ000	0	
L401	G1A330G00004	COIL	
L403	J0JHC0000035	CERAMIC FILTER	
L405	PFVFLA471SG	CERAMIC FILTER	
L406	PFVFLA471SG	CERAMIC FILTER	
L407	PFVFLA471SG	CERAMIC FILTER	
L408	PFVFLA471SG	CERAMIC FILTER	
L409	PFVFLA471SG	CERAMIC FILTER	
L410	PFVFLA471SG	CERAMIC FILTER	
L411	PFVFLA471SG	CERAMIC FILTER	
L412	PFVFLA471SG	CERAMIC FILTER	
L413	PFVFP2P600SG	CERAMIC FILTER	
L414	ERJ3GEY0R00	0	
L415	ERJ3GEY0R00	0	
L416	ERJ3GEY0R00	0	
L417	ERJ3GEY0R00	0	
L418	ERJ3GEY0R00	0	
L419	ERJ3GEY0R00	0	
L420	ERJ3GEY0R00	0	
L421	ERJ3GEY0R00	0	
		(FUSES)	
IP401	K5H502Z00003	FUSE	
IP402	K5H252Z00003	FUSE	
		(BATTERY)	
BAT401	CR23541GUF	LITHIUM BATTERY	
		(SWITCHES)	
SW101	EVQPF106K	SWITCH	
SW103	PQSS2A26Y	SWITCH	
		(CRYSTAL OSCILLATORS)	

Ref. No.	Part No.	Part Name & Description	Remarks
X101	PSVCC0025GT	CRYSTAL OSCILLATOR	
X102	PSVCC0019CT	CRYSTAL OSCILLATOR	
X103	H1B1635B0016	CRYSTAL OSCILLATOR	
X201	H0J120500019	CRYSTAL OSCILLATOR	
X202	H0J200500030	CRYSTAL OSCILLATOR	
		(OTHERS)	
E1	PQDF996Z	SHAFT	
E2	PQHR10005Z	SPACER	
E3	PQUB14Z2	LEVER	PA-V0
E4	PSGE1005Z	COVER	ABS-HB
E5	PSGE1006Z	COVER	ABS-HB
E6	PSHD1088Z	SCREW	ABS-HB
E7	PSHE1122Z	SPACER	
E8	PSMH1208Z	CHASSIS	
E9	PSUS1020Z	SPRING	
E10	PSUS1021Y	SPRING	
E11	XUC25VWV	RETAINING-RING	
E12	XYN3+F6	SCREW	

18.4. BACK/LED BOARD PARTS

Ref. No.	Part No.	Part Name & Description	Remarks
PCB2	PSWP2DA200AL	BACK/LED BOARD ASS'Y (RTL)	
		(DIODES)	
LED201	LN316GP	LED	
LED202	LN216RP	LED	
		(CONNECTORS)	
CN100	PSJS44A07Y	CONNECTOR, 44P	
CN101	K1KB90A00014	CONNECTOR, 90P	
CN102	K1KB90A00014	CONNECTOR, 90P	
CN103	K1KB90A00014	CONNECTOR, 90P	
CN104	K1KB90A00014	CONNECTOR, 90P	
CN105	K1KB90A00014	CONNECTOR, 90P	
CN106	K1KB90A00014	CONNECTOR, 90P	
CN107	K1KB90A00014	CONNECTOR, 90P	
CN108	K1KB90A00014	CONNECTOR, 90P	
CN109	K1KB90A00014	CONNECTOR, 90P	
CN110	K1KB90A00014	CONNECTOR, 90P	
CN111	K1KB90A00014	CONNECTOR, 90P	
CN112	K1KB90A00014	CONNECTOR, 90P	
CN113	K1KA09B00077	CONNECTOR, 9P	
CN114	PQJP3G38Z	CONNECTOR, 3P	
CN201	PQJP3D68Z	CONNECTOR, 3P	
		(CAPACITORS)	
C101	PQCUV1A225ZF	2.2	
C106	ECUV1C104ZFV	0.1	
C107	ECUV1C104ZFV	0.1	
C108	ECUV1C104ZFV	0.1	
C109	ECUV1C104ZFV	0.1	
C110	ECUV1C104ZFV	0.1	
C111	ECUV1C104ZFV	0.1	
C201	PQCUV1A225ZF	2.2	
C202	ECUV1C104ZFV	0.1	
C203	ECUV1C104ZFV	0.1	
C204	ECUV1C104ZFV	0.1	
C205	ECUV1C104ZFV	0.1	
C206	ECUV1C104ZFV	0.1	
C207	ECUV1C104ZFV	0.1	
		(RESISTORS)	
R101	ERJ3GEYJ103	10k	
R102	ERJ3GEYJ103	10k	
R105	ERJ3GEYJ103	10k	
R106	ERJ3GEYJ103	10k	
R107	ERJ3GEYJ103	10k	
R108	ERJ3GEYJ103	10k	
R109	ERJ3GEYJ103	10k	

Ref. No.	Part No.	Part Name & Description	Remarks
R110	ERJ3GEYJ103	10k	
R147	ERJ3GEYJ103	10k	
R148	ERJ3GEYJ103	10k	
R151	ERJ3GEYJ103	10k	
R152	ERJ3GEYJ103	10k	
R153	ERJ3GEYJ103	10k	
R154	ERJ3GEYJ103	10k	
R155	ERJ3GEYJ103	10k	
R156	ERJ3GEYJ103	10k	
R157	ERJ3GEYJ103	10k	
R165	ERJ3GEYJ103	10k	
R166	ERJ3GEYJ103	10k	
R167	ERJ3GEYJ103	10k	
R168	ERJ3GEYJ103	10k	
R169	ERJ3GEYJ103	10k	
R170	ERJ3GEYJ103	10k	
R177	ERJ3GEYJ103	10k	
R178	ERJ3GEYJ103	10k	
R179	ERJ3GEYJ103	10k	
R180	ERJ3GEYJ103	10k	
R181	ERJ3GEYJ103	10k	
R182	ERJ3GEYJ103	10k	
R189	ERJ3GEYJ103	10k	
R190	ERJ3GEYJ103	10k	
R191	ERJ3GEYJ103	10k	
R192	ERJ3GEYJ103	10k	
R193	ERJ3GEYJ103	10k	
R199	ERJ3GEYJ103	10k	
R200	ERJ3GEYJ103	10k	
R201	ERJ3GEYJ103	10k	
R202	ERJ3GEYJ103	10k	
R343	ERJ3GEYJ103	10k	
R344	ERJ3GEYJ103	10k	
R345	ERJ3GEYJ103	10k	
		(FILTERS)	
L101	PFVF1A471SG	CERAMIC FILTER	
L102	PFVF1A471SG	CERAMIC FILTER	
L103	PFVF1A471SG	CERAMIC FILTER	
L104	PFVF1A471SG	CERAMIC FILTER	
L105	PFVF1A471SG	CERAMIC FILTER	
L106	PFVF1A471SG	CERAMIC FILTER	
L107	PFVF1A471SG	CERAMIC FILTER	
L108	PFVF1A471SG	CERAMIC FILTER	
L109	PFVF1A471SG	CERAMIC FILTER	
L110	PFVF1A471SG	CERAMIC FILTER	
L111	PFVF1A471SG	CERAMIC FILTER	
L112	PFVF1A471SG	CERAMIC FILTER	
		(OTHER)	
E21	PSHR1276Z	SPACER	

18.5. FIXTURES AND TOOLS

Ref. No.	Part No.	Part Name & Description	Remarks
EC1	PSZZ1TDA100M	EXTENSION BOARD (FOR CPU CARD)	
EC2	PSZZ2TDA100M	EXTENSION BOARD (FOR LINE CARD)	

Note:

EC1 and EC2 are necessity for servicing.

19 FOR THE SCHEMATIC DIAGRAM

Note:

1. DC voltage measurements are taken with an oscilloscope or a tester with a ground.
2. The schematic diagrams and circuit board may be modified at any time with the development of new technology.

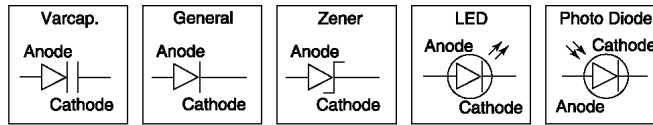

Important safety notice

Components identified by  mark have special characteristics important for safety. When replacing any of these components, use only manufacturer's specified parts.

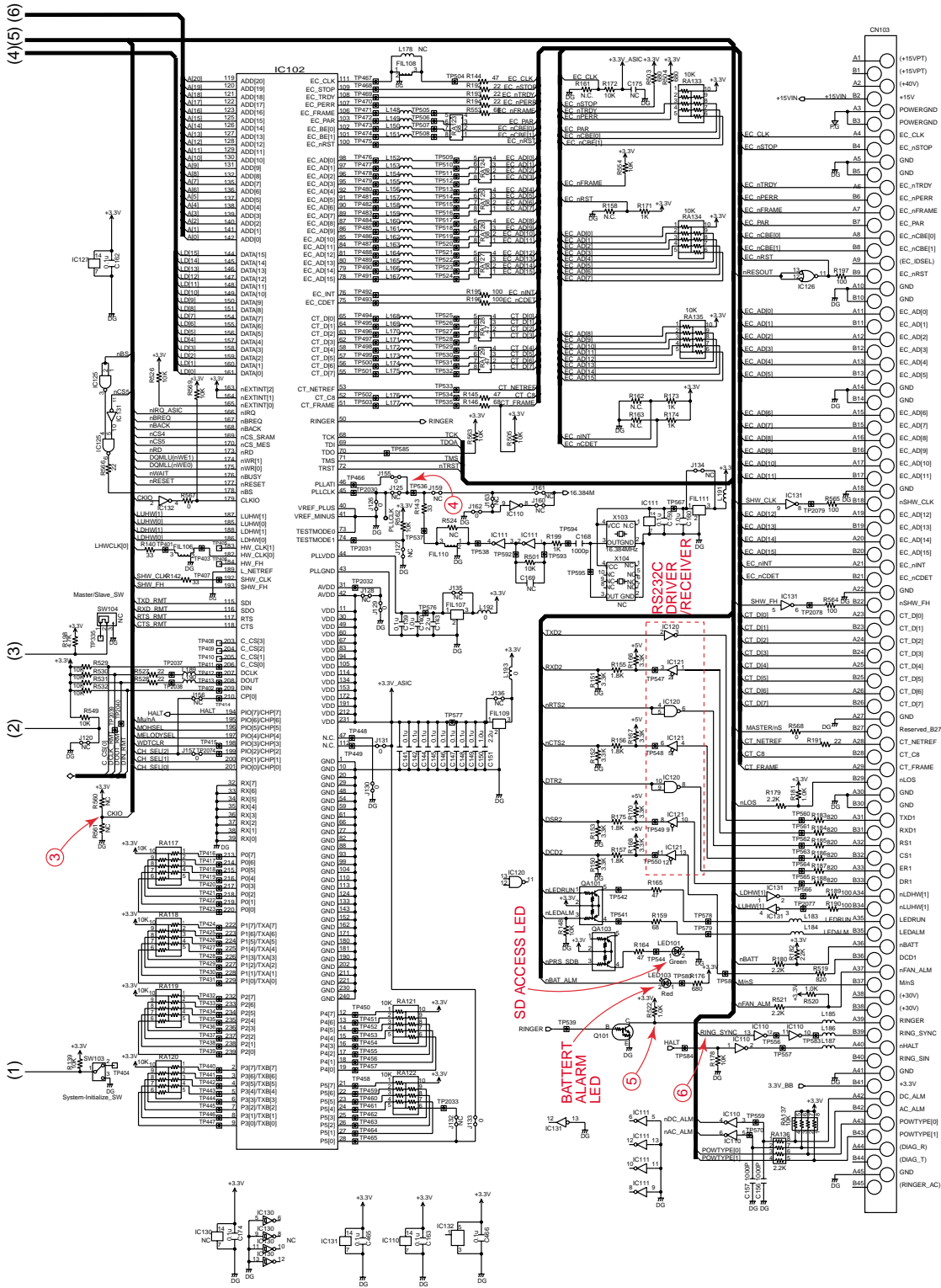

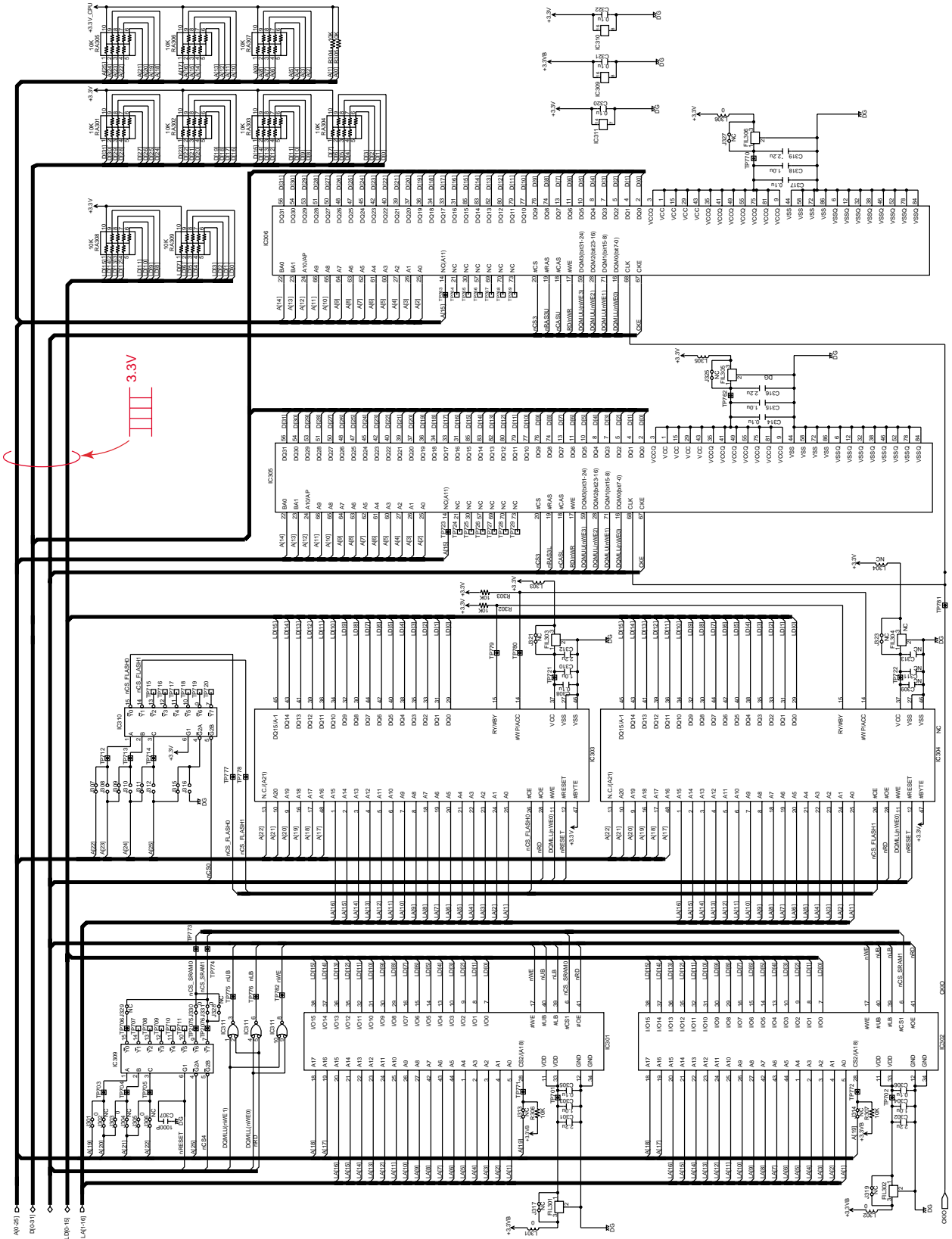

KX-TDA200 MPR CARD 4/5

02050127/203

02050127/202

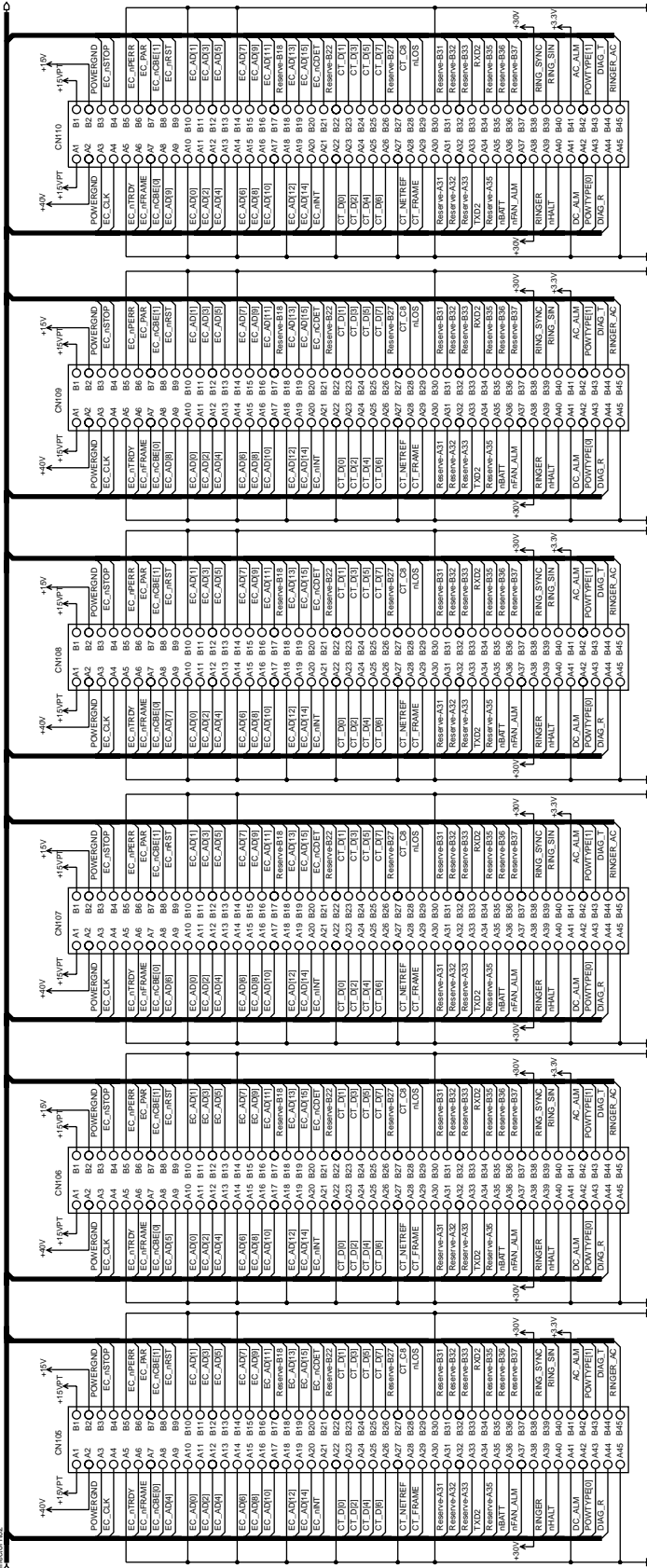

KX-TDA200 BACK/LED BOARD 2/3

20.3. WAVEFORM

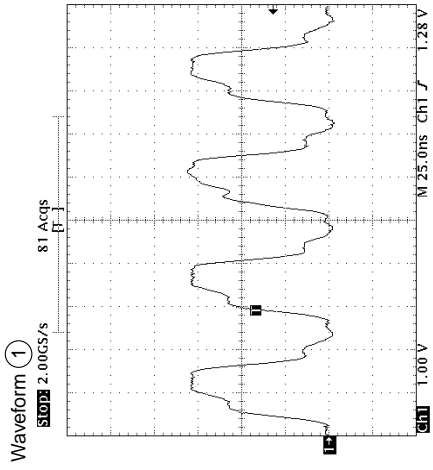

16.384MHz

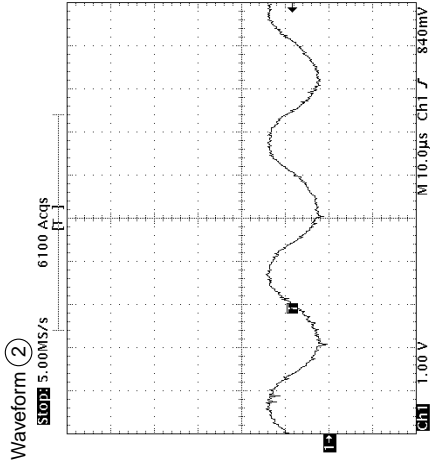

32.768kHz

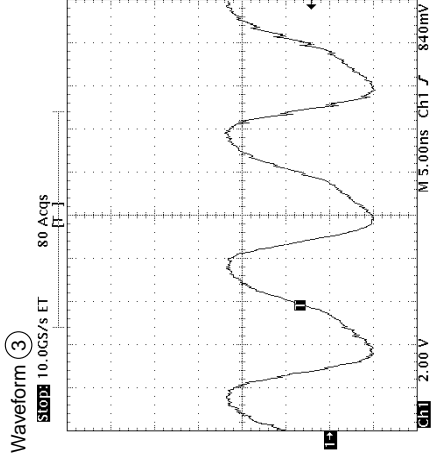

65.536MHz

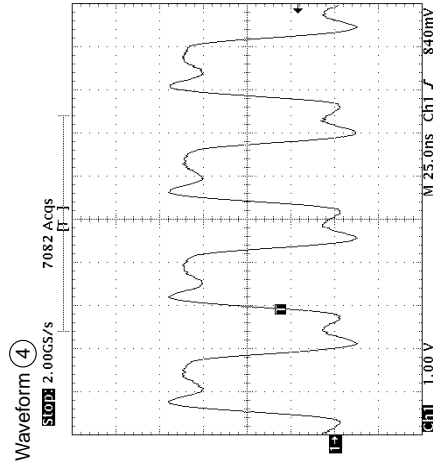

16.384MHz

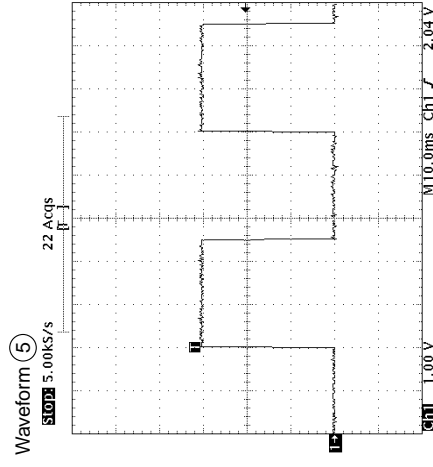

Switching the frequency of 20Hz/25Hz is possible by the soft setting. The above-mentioned waveform is the example of 20Hz.

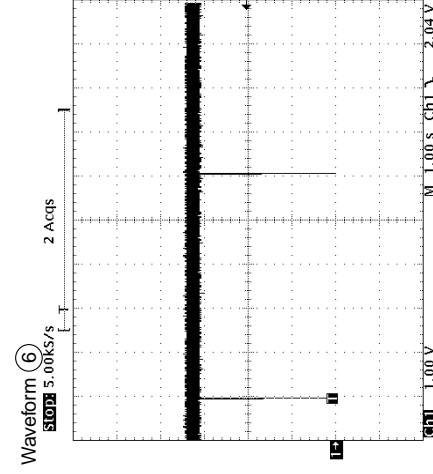

Switching the pulse spacing of 2976msec/3840msec /4992msec/5120msec is possible by the soft setting. The above-mentioned waveform is the example of 5120msec.

Waveform ⑦

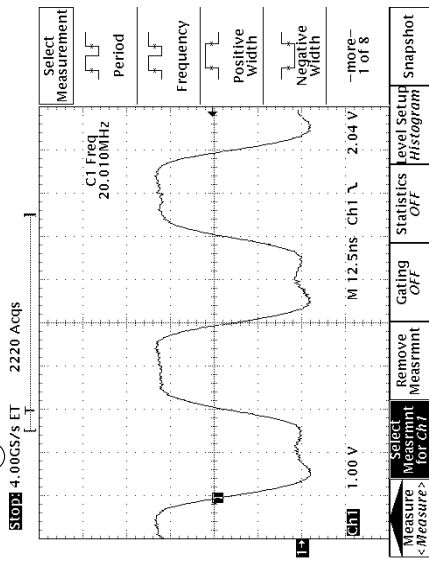

20MHz

Waveform ⑧

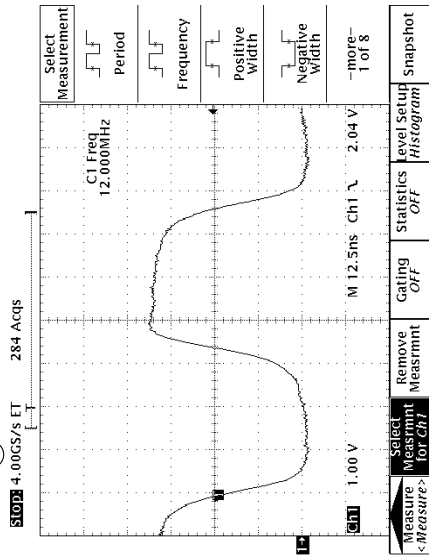

12MHz

21 PRINTED CIRCUIT BOARD

21.1. MPR CARD

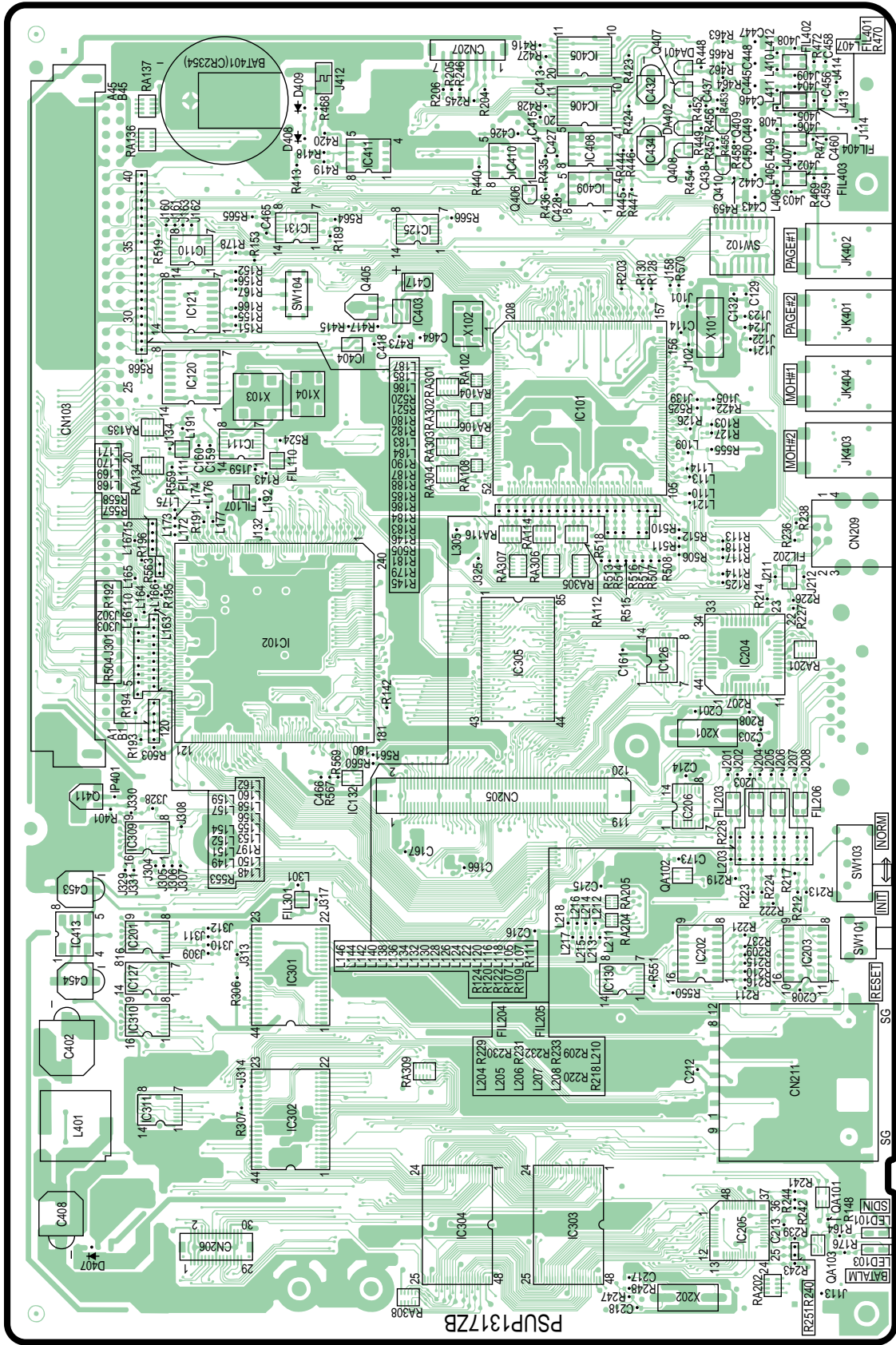

KX-TDA200 MPR CARD COMPONENT VIEW

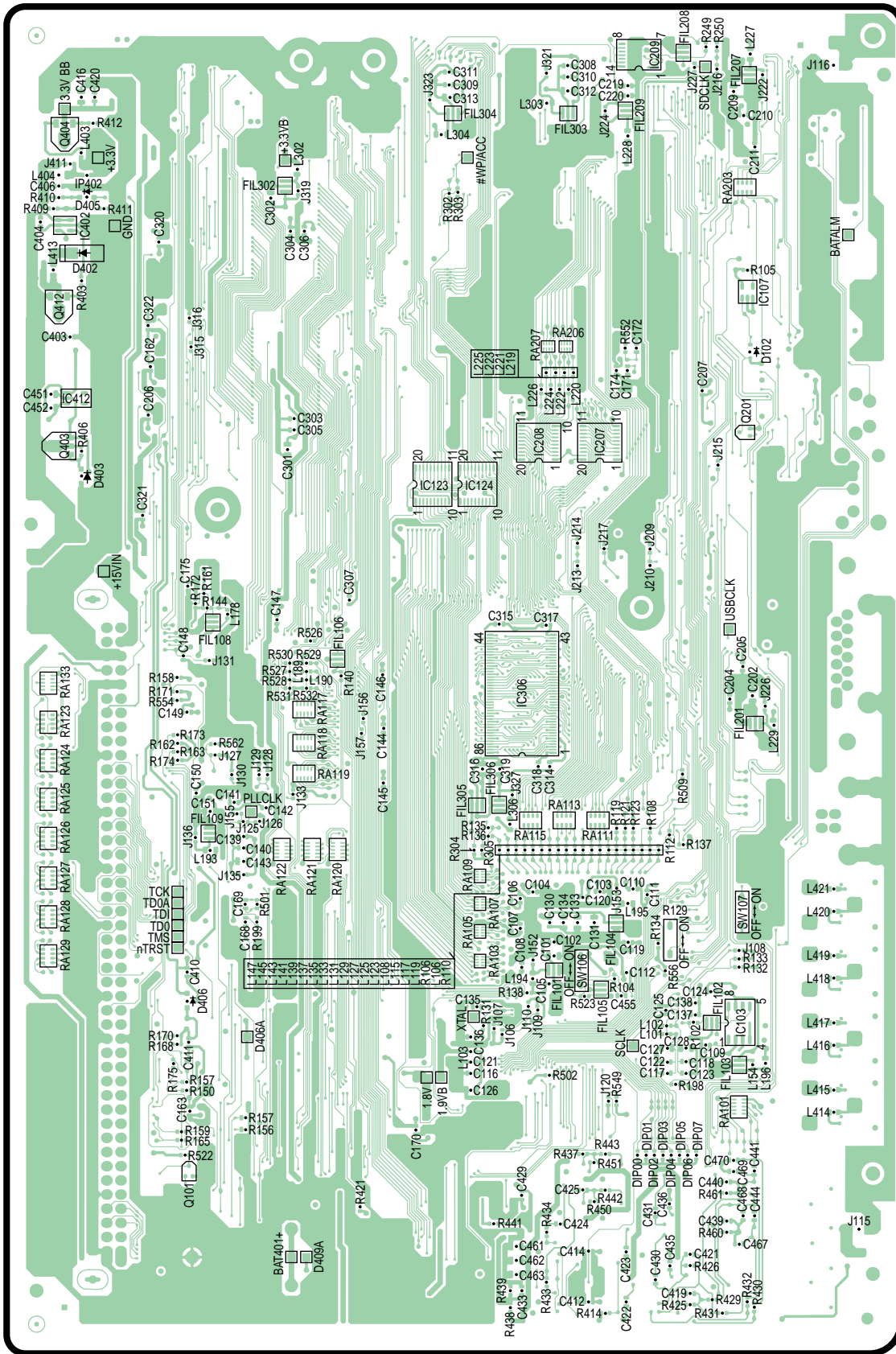

KX-TDA200 MPR CARD BOTTOM VIEW

21.2. BACK/LED BOARD

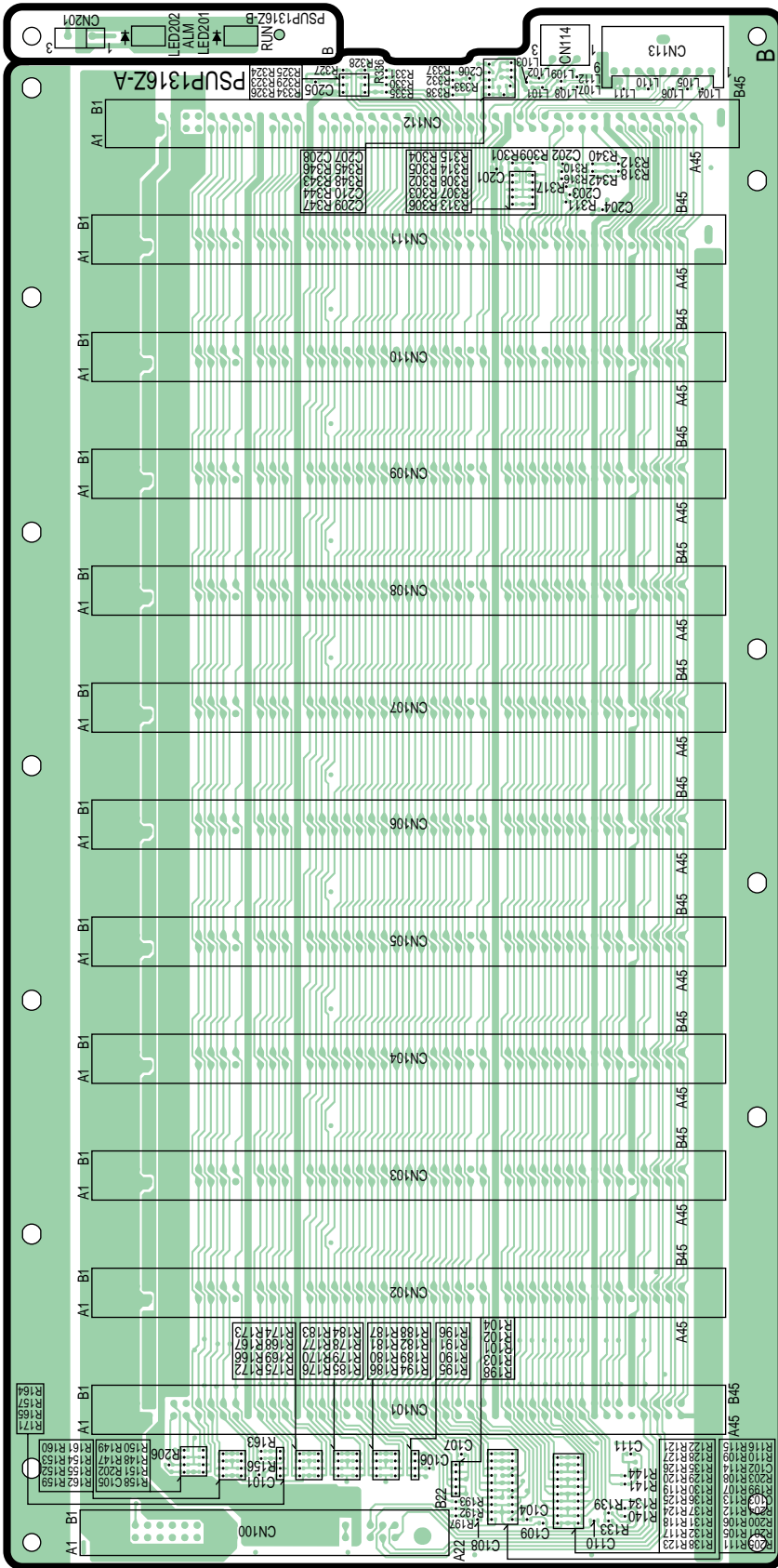

KX-TDA200 BACK/LED BOARD COMPONENT VIEW

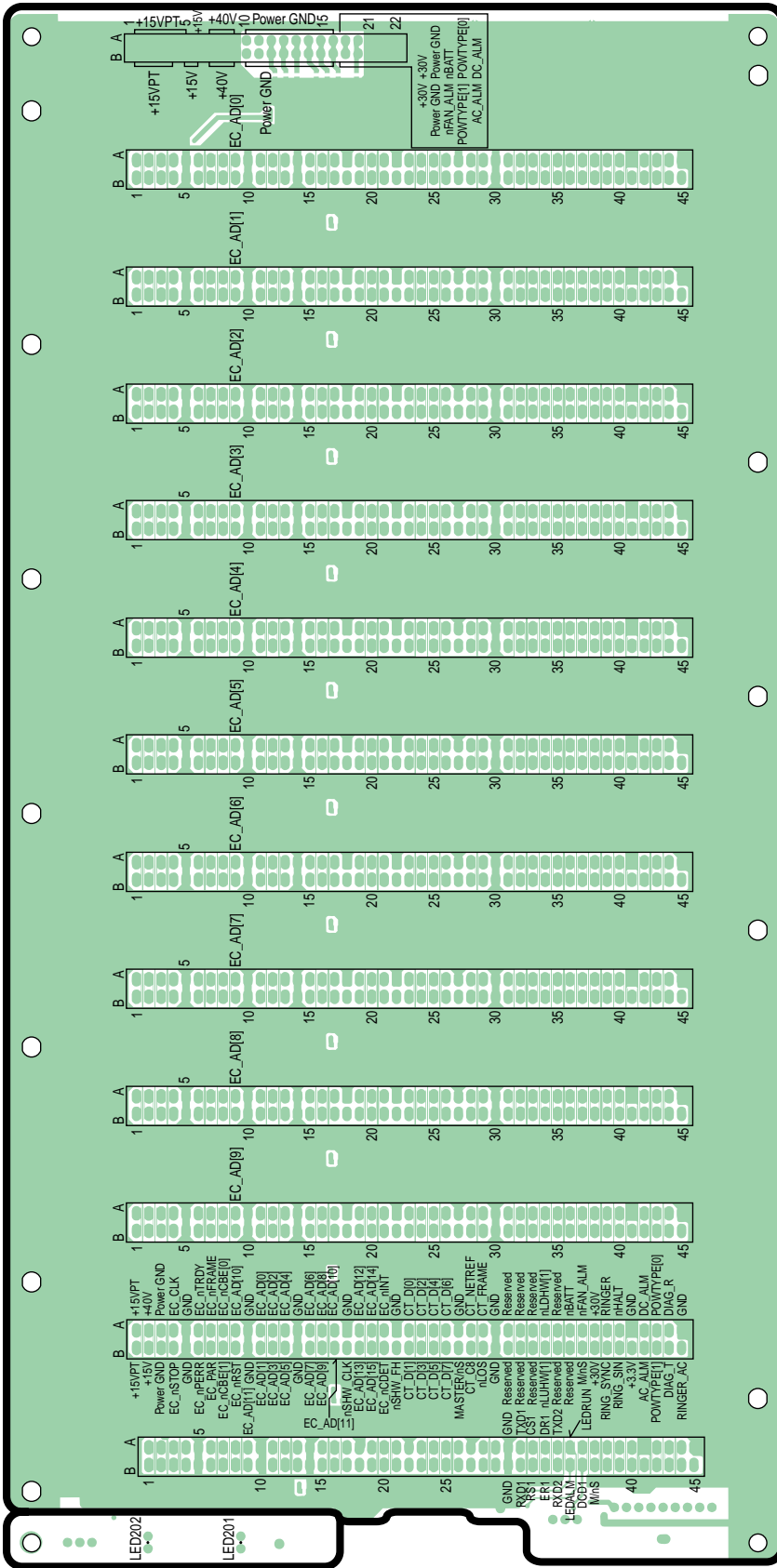

KX-TDA200 BACK/LED BOARD BOTTOM VIEW

